

HISTORY INFORMATION FOR THE FOLLOWING MANUAL:

SERVICE MANUAL

BA-5D CHASSIS

<u>MODEL NAME</u>	<u>REMOTE COMMANDER</u>	<u>DESTINATION</u>	<u>CHASSIS NO.</u>
KV-27FV300	RM-Y181	US	SCC-S65AA
KV-27FV300	RM-Y181	CND	SCC-S64AA
KV-29FV300	RM-Y181	LATIN NORTH	SCC-S62BA
KV-29FV300	RM-Y181	LATIN SOUTH	SCC-S62CA
KV-32FV300	RM-Y182	US	SCC-S65BA
KV-32FV300	RM-Y182	CND	SCC-S64BA
KV-36FV300	RM-Y182	US	SCC-S65CA
KV-36FV300	RM-Y182	CND	SCC-S64CA
KV-36FV300	RM-Y182	HAWAII	SCC-S67AA

ORIGINAL MANUAL ISSUE DATE: 3/2002

 :UPDATED ITEM

<u>REVISION DATE</u>	<u>REVISION TYPE</u>	<u>SUBJECT</u>
3/2002	No revisions or updates are applicable at this time.	
5/2002	Correction - 1	Critical parts incorrectly indentified in Exploded View, Electrical Parts List, A Board Schematic. (Replace pgs. 31, 55,57,59, & 70)
10/2002	Correction - 2	Exploded View PN correction for Door (Replace pgs. 56, 58, & 60)
12/2004	Updated A Board Schematic to include CN903 and CN905 Connectors for headphones. (Replace pg. 31)	

TRINITRON® COLOR TELEVISION
SONY®

SERVICE MANUAL

BA-5D CHASSIS

<u>MODEL NAME</u>	<u>REMOTE COMMANDER</u>	<u>DESTINATION</u>	<u>CHASSIS NO.</u>
KV-27FV300	RM-Y181	US	SCC-S65AA
KV-27FV300	RM-Y181	CND	SCC-S64AA
KV-29FV300	RM-Y181	LATIN NORTH	SCC-S62BA
KV-29FV300	RM-Y181	LATIN SOUTH	SCC-S62CA
KV-32FV300	RM-Y182	US	SCC-S65BA
KV-32FV300	RM-Y182	CND	SCC-S64BA
KV-36FV300	RM-Y182	US	SCC-S65CA
KV-36FV300	RM-Y182	CND	SCC-S64CA
KV-36FV300	RM-Y182	HAWAII	SCC-S67AA



KV-36FV300



RM-Y182

TRINITRON® COLOR TELEVISION

SONY®

TABLE OF CONTENTS

SECTION TITLE	PAGE
Specifications.....	4
Warnings and Cautions.....	5
Safety Check-Out	6
Self-Diagnostic Function.....	7
1. Disassembly	
1-1. Rear Cover Removal	10
1-2. Chassis Assembly Removal	10
1-3. Service Position	10
1-4. Picture Tube Removal	11
Anode Cap Removal Procedure.....	11
2. Set-up Adjustments	
2-1. Beam Landing	12
2-2. Convergence	13
2-3. Focus.....	15
2-4. Screen (G2).....	15
2-5. White Balance Adjustments.....	15
3. Safety Related Adjustments	
3-1. <input checked="" type="checkbox"/> R530, R531 Confirmation Method (Hold-Down Confirmation) and Readjustments	16
3-2. B+ Voltage Confirmation and Adjustment	16
4. Circuit Adjustments	
4-1. Setting Service Adjustment Mode.....	17
4-2. Memory Write Confirmation Method	17
4-3. Remote Adjustment Buttons and Indicators	17
4-4. Service Data Lists.....	18
4-5. ID Map Table	26
4-6. Board Adjustments	26
5. Diagrams	
5-1. Circuit Board Location	29
5-2. Printed Wiring Board and Schematic Diagrams Information	29
5-3. Block Diagram and Schematics.....	30
A Board Schematic Diagram	31
BC Board Schematic Diagram	39
HU Board Schematic Diagram.....	42
P Board Schematic Diagram	44
HR Board Schematic Diagram.....	46
T Board Schematic Diagram.....	47
C Board Schematic Diagram	48
V Board Schematic Diagram	50
GK Board Schematic Diagram.....	52
5-4. Semiconductors	54
6. Exploded Views	
6-1. Chassis (KV-27FV300/29FV300 ONLY).....	55
6-2. Picture Tube (KV-27FV300/29FV300 ONLY)	56
6-3. Chassis (KV-32FV300 ONLY)	57
6-4. Picture Tube (KV-32FV300 ONLY)	58
6-5. Chassis (KV-36FV300 ONLY)	59
6-6. Picture Tube (KV-36FV300 ONLY)	60
7. Electrical Parts List	61

SPECIFICATIONS

	KV-27FV300 KV-29FV300	KV-32FV300	KV-36FV300
Power Requirements	120V, 60Hz		
Number of Inputs/Outputs			
Video ¹⁾	3		
S Video ²⁾	2		
Y, P_B, P_R ³⁾	1		
Audio ⁴⁾	3		
Audio Out ⁵⁾	1		
Monitor Out	1		
Speaker Output (W)	7.5 W x 2, 15 W subwoofer		
Power Consumption (W)			
In Use (Max)	220 W	230 W	230 W
In Standby	1W	1W	1W
Dimensions (W x H x D)			
mm	784 x 601.5 x 520 mm	898 x 682 x 584 mm	1020 x 760 x 640 mm
in	30 ^{7/8} x 23 ^{11/16} x 20 ^{1/2} in	35 ^{3/8} x 26 ^{7/8} x 23 in	40 ^{1/4} x 30 x 25 ^{1/4} in
Mass			
kg	48 kg	78 kg	102 kg
lbs	105 lbs. 13 oz.	171 lbs. 15 oz.	224 lbs. 14 oz.

Television system

American TV standard, NTSC

Channel coverage

VHF: 2-13/ UHF: 14-69/ CATV: 1-125

Picture tubeFD Trinitron[®] tube**Visible screen size**

27 inch picture measured diagonally (KV-27FV300/29FV300)

32 inch picture measured diagonally (KV-32FV300)

36 inch picture measured diagonally (KV-36FV300)

Actual screen size

29 inch measured diagonally (KV-27FV300/29FV300)

34 inch measured diagonally (KV-32FV300)

38 inch measured diagonally (KV-36FV300)

Antenna

75-ohm external antenna terminal for VHF/UHF

Supplied Accessories

Size AA (R6) batteries (2)

Remote Control RM-Y181 (1) (KV-27FV300/29FV300)

Remote Control RM-Y182 (1) (KV-32FV300/36FV300)

Wireless Headphones (1) (KV-32FV300/36FV300)

Optional Accessories

TV Stand: SU-27HV2 for (KV-27K300/29FV300)

SU-32HV3 for (KV-32K300)

SU-36HV3 for (KV-36K300)

- 1) 1 Vp-p 75 ohms unbalanced, sync negative
- 2) Y: 1 Vp-p 75 ohms unbalanced, sync negative
C: 0.286 Vp-p (Burst signal), 75 ohms
- 3) Y: 1.0 Vp-p, 75 ohms, sync negative;
PB: 0.7 Vp-p, 75 ohms
PR: Vp-p, 75 ohms
- 4) 500 mVrms (100% modulation), Impedance: 47 kilohms
- 5) More than 408 mVrms at the maximum volume setting (variable)
More than 408 mVrms (fix)

XBR

TruSurround[™]
by SRS

TruSurround is a trademark of SRS Labs, Inc. SRS and the SRS symbol are registered trademarks of SRS Labs, Inc. in the United States and in select foreign countries. SRS and TruSurround are incorporated under license from SRS Labs, Inc. and are protected under United States Patent Nos. 4,748,669 and 4,841,572 with numerous additional issued and pending foreign patents. Purchase of this product does not convey the right to sell recordings made with the TruSurround technology.

(●) SRS (SOUND RETRIEVAL SYSTEM)

The (●) SRS (SOUND RETRIEVAL SYSTEM) is manufactured by Sony Corporation under license from SRS Labs, Inc. It is covered by U.S. Patent No. 4,748,669. Other U.S. and foreign patents pending.

The word 'SRS' and the SRS symbol (●) are registered trademarks of SRS Labs, Inc. BBE and BBE symbol are trademarks of BBE Sound, Inc. and are licensed by BBE Sound, Inc. under U.S. Patent No. 4,638,258 and 4,482,866.

Design and specifications are subject to change without notice.

WARNINGS AND CAUTIONS

CAUTION

Short circuit the anode of the picture tube and the anode cap to the metal chassis, CRT shield, or carbon painted on the CRT, after removing the anode.

WARNING!!

An isolation transformer should be used during any service to avoid possible shock hazard, because of live chassis. The chassis of this receiver is directly connected to the ac power line.



SAFETY-RELATED COMPONENT WARNING!!

Components identified by shading and  mark on the schematic diagrams, exploded views, and in the parts list are critical for safe operation. Replace these components with Sony parts whose part numbers appear as shown in this manual or in supplements published by Sony. Circuit adjustments that are critical for safe operation are identified in this manual. Follow these procedures whenever critical components are replaced or improper operation is suspected.

ATTENTION!!

Après avoir déconnecté le cap de l'anode, court-circuiter l'anode du tube cathodique et celui de l'anode du cap au châssis métallique de l'appareil, ou la couche de carbone peinte sur le tube cathodique ou au blindage du tube cathodique.

Afin d'éviter tout risque d'électrocution provenant d'un châssis sous tension, un transformateur d'isolement doit être utilisé lors de tout dépannage. Le châssis de ce récepteur est directement raccordé à l'alimentation du secteur.



ATTENTION AUX COMPOSANTS RELATIFS A LA SECURITE!!

Les composants identifiés par une trame et par une marque  sur les schémas de principe, les vues explosées et les listes de pièces sont d'une importance critique pour la sécurité du fonctionnement. Ne les remplacer que par des composants Sony dont le numéro de pièce est indiqué dans le présent manuel ou dans des suppléments publiés par Sony. Les réglages de circuit dont l'importance est critique pour la sécurité du fonctionnement sont identifiés dans le présent manuel. Suivre ces procédures lors de chaque remplacement de composants critiques, ou lorsqu'un mauvais fonctionnement suspecte.

SAFETY CHECK-OUT

After correcting the original service problem, perform the following safety checks before releasing the set to the customer:

1. Check the area of your repair for unsoldered or poorly soldered connections. Check the entire board surface for solder splashes and bridges.
2. Check the interboard wiring to ensure that no wires are "pinched" or touching high-wattage resistors.
3. Check that all control knobs, shields, covers, ground straps, and mounting hardware have been replaced. Be absolutely certain that you have replaced all the insulators.
4. Look for unauthorized replacement parts, particularly transistors, that were installed during a previous repair. Point them out to the customer and recommend their replacement.
5. Look for parts which, though functioning, show obvious signs of deterioration. Point them out to the customer and recommend their replacement.
6. Check the line cords for cracks and abrasion. Recommend the replacement of any such line cord to the customer.
7. Check the B+ and HV to see if they are specified values. Make sure your instruments are accurate; be suspicious of your HV meter if sets always have low HV.
8. Check the antenna terminals, metal trim, "metallized" knobs, screws, and all other exposed metal parts for AC leakage. Check leakage as described below.

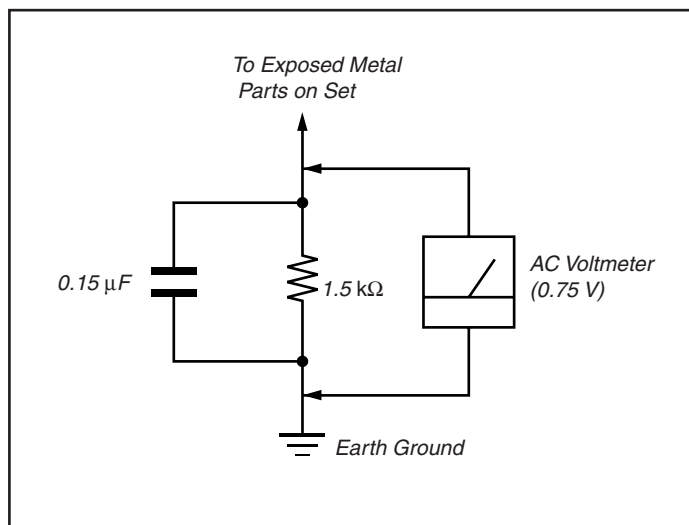

Figure A. Using an AC voltmeter to check AC leakage.

Leakage Test

The AC leakage from any exposed metal part to earth ground and from all exposed metal parts to any exposed metal part having a return to chassis, must not exceed 0.5 mA (500 microamperes). Leakage current can be measured by any one of three methods.

1. A commercial leakage tester, such as the Simpson 229 or RCA WT-540A. Follow the manufacturers' instructions to use these instructions.
2. A battery-operated AC milliampmeter. The Data Precision 245 digital multimeter is suitable for this job.
3. Measuring the voltage drop across a resistor by means of a VOM or battery-operated AC voltmeter. The "limit" indication is 0.75 V, so analog meters must have an accurate low voltage scale. The Simpson's 250 and Sanwa SH-63TRD are examples of passive VOMs that are suitable. Nearly all battery-operated digital multimeters that have a 2 VAC range are suitable (see Figure A).

How to Find a Good Earth Ground

A cold-water pipe is a guaranteed earth ground; the cover-plate retaining screw on most AC outlet boxes is also at earth ground. If the retaining screw is to be used as your earth ground, verify that it is at ground by measuring the resistance between it and a cold-water pipe with an ohmmeter. The reading should be zero ohms.

If a cold-water pipe is not accessible, connect a 60- to 100-watt trouble-light (not a neon lamp) between the hot side of the receptacle and the retaining screw. Try both slots, if necessary, to locate the hot side on the line; the lamp should light at normal brilliance if the screw is at ground potential (see Figure B).

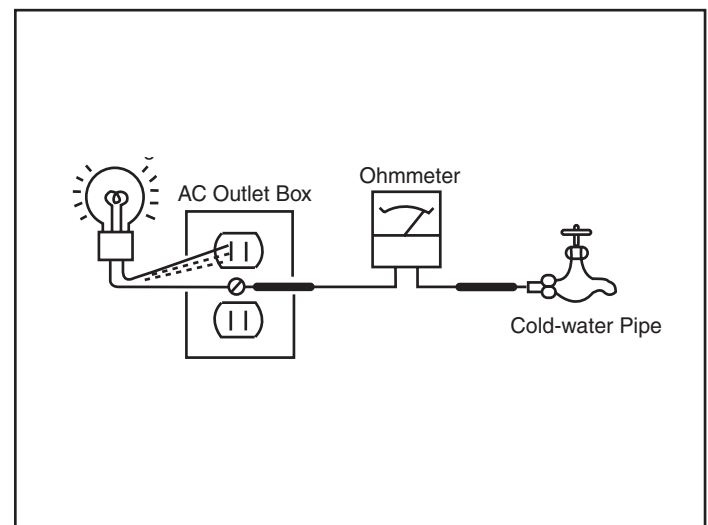

Figure B. Checking for earth ground.

SELF-DIAGNOSTIC FUNCTION



The units in this manual contain a self-diagnostic function. If an error occurs, the STANDBY/TIMER LED will automatically begin to flash. The number of times the LED flashes translates to a probable source of the problem. A definition of the STANDBY/TIMER LED flash indicators is listed in the instruction manual for the user's knowledge and reference. If an error symptom cannot be reproduced, the Remote Commander can be used to review the failure occurrence data stored in memory to reveal past problems and how often these problems occur.

Diagnostic Test Indicators

When an error occurs, the STANDBY/TIMER LED will flash a set number of times to indicate the possible cause of the problem. If there is more than one error, the LED will identify the first of the problem areas.

Results for all of the following diagnostic items are displayed on screen. If the screen displays a "0", an error has occurred.

Diagnostic Item	No. of times STANDBY / TIMER lamp flashes	Probable Cause Location	Detected Symptoms
Power does not turn on	Does not light	<ul style="list-style-type: none"> Power cord is not plugged in. Fuse is burned out (F601). (GK Board) 	<ul style="list-style-type: none"> Power does not come on. No power is supplied to the TV. AC Power supply is faulty.
+B overcurrent (OCP)*	2 times	<ul style="list-style-type: none"> H.OUT (Q502) is shorted. (A Board) IC702 is shorted. (C Board) 	<ul style="list-style-type: none"> Power does not come on. Load on power line shorted.
+B overvoltage (OVP)	3 times	<ul style="list-style-type: none"> IC501 is faulty. (A Board) If a high is supplied to pin 2 of IC501. (A Board) 	<ul style="list-style-type: none"> Has entered standby mode.
I-Prot	4 times	<ul style="list-style-type: none"> +12V is not supplied. (A Board) IC561 is faulty. (A Board) 	<ul style="list-style-type: none"> Has entered standby state after horizontal raster. Vertical deflection pulse is stopped. Power line is shorted or power supply is stopped.
IK (AKB)	5 times	<ul style="list-style-type: none"> Video OUT (IC561) is faulty. (A Board) IC702 is faulty. (C Board) Screen (G2) is improperly adjusted. ** 	<ul style="list-style-type: none"> No raster is generated. CRT Cathode current detection reference pulse output is small.
Zero Cross	9 times	<ul style="list-style-type: none"> No zero cross pulses on pin 45 IC1001. (A Board) 	<ul style="list-style-type: none"> Power does not come on.
9V Check	10 times	<ul style="list-style-type: none"> Relay failed (RY600) 	<ul style="list-style-type: none"> Power does not come on.

* If a +B overcurrent is detected, stoppage of the vertical deflection is detected simultaneously. The symptom that is diagnosed first by the microcontroller is displayed on the screen.

** Refer to Screen (G2) Adjustments in Section 2-4 of this manual

Display of Standby/Timer LED Flash Count

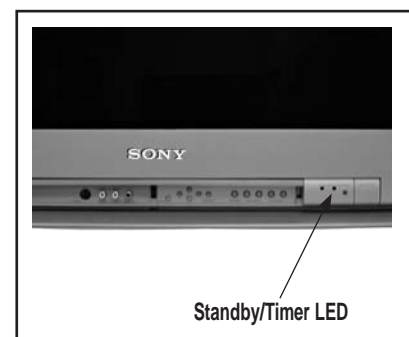
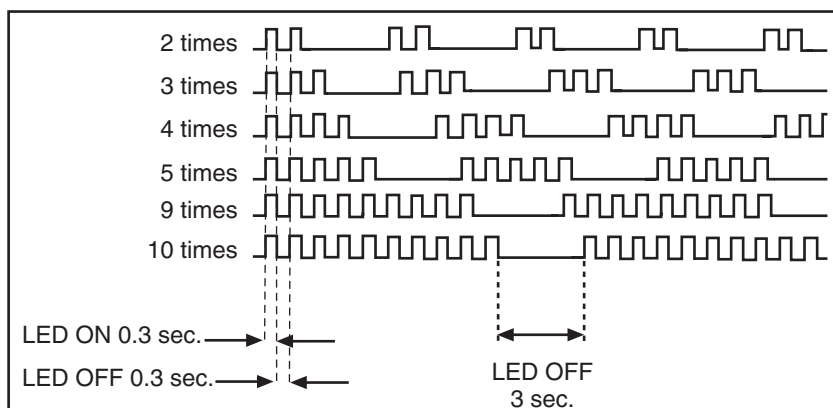

Diagnostic Item	Flash Count*
+B Overcurrent	2 times
+B Overvoltage	3 times
V-STOP	4 times
IK (AKB)	5 times
Zero Cross	9 times
9V	10 times

*One flash count is not used for self-diagnostic.

Stopping the Standby/Timer LED Flash

Turn off the power switch on the TV main unit or unplug the power cord from the outlet to stop the STANDBY/TIMER LAMP from flashing.

Self-Diagnostic Screen Display

For errors with symptoms such as "power sometimes shuts off" or "screen sometimes goes out" that cannot be confirmed, it is possible to bring up past occurrences of failure on the screen for confirmation.

To Bring Up Screen Test

In standby mode, press buttons on the Remote Commander sequentially, in rapid succession, as shown below:

DISPLAY → Channel **5** → Sound volume **0** → Power ON.

SELF DIAGNOSIS	
2: +B OCP	0
3: +B OVP	0
4: VSTOP	0
5: AKB	1
9: ZCD	0
10: 9VON	0
101: WDT	0
Serial: xxxxxxx	
Model: xxxxxxx	

Numeral "0" means that no fault was detected.

Numeral "1" means a fault was detected one time only.

Handling of Self-Diagnostic Screen Display

Since the diagnostic results displayed on the screen are not automatically cleared, always check the self-diagnostic screen during repairs. When you have completed the repairs, clear the result display to "0".

Unless the result display is cleared to "0", the self-diagnostic function will not be able to detect subsequent faults after completion of the repairs.

Clearing the Result Display

To clear the result display to "0", press buttons on the Remote Commander sequentially when the diagnostic screen is displayed, as shown below:

Channel **8** → **ENTER**

Quitting the Self-Diagnostic Screen

To quit the entire self-diagnostic screen, turn off the power switch on the Remote Commander or the main unit.

Self-Diagnostic Circuit

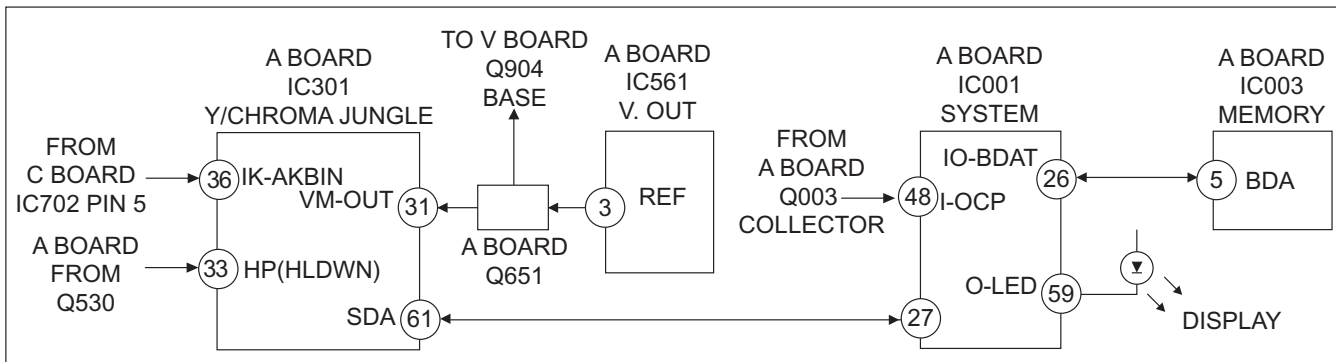

+B overcurrent (OCP)

Occurs when an overcurrent on the +B (135V) line is detected by pin 48 of IC001 (A Board). If the voltage of pin 48 of IC001 (A Board) is less than 1V when V.SYNC is more than seven verticals in a period, the unit will automatically turn off.

+B overvoltage (OVP)

Occurs when a high is felt on pin 2 of IC501 (A Board).

I-PROT

Occurs when an absence of the vertical deflection pulse is detected by pin 31 of IC301 (A Board). Power supply will shut down when waveform interval exceeds 2 seconds.

IK (AKB)

If the RGB levels* do not balance within 2 seconds after the power is turned on, this error will be detected by IC301 (A Board). TV will stay on, but there will be no picture.

*(Refers to the RGB levels of the AKB detection Ref pulse that detects 1K).

Zero Cross

Check Q691 collector (GK Board) 7.5V STBY goes to 0V when the set is turned on.

9V Check

Check Q691 collector (GK Board) 7.5V STBY goes to 0V when the set is turned on.

SECTION 1: DISASSEMBLY

1-1. REAR COVER REMOVAL

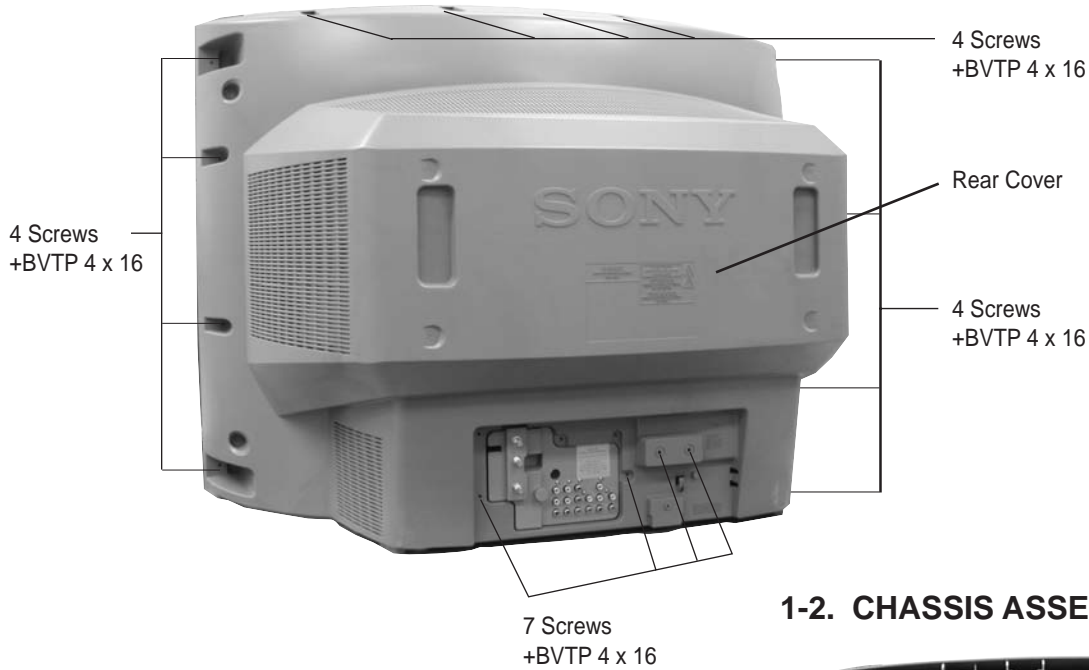

1-2. CHASSIS ASSEMBLY REMOVAL

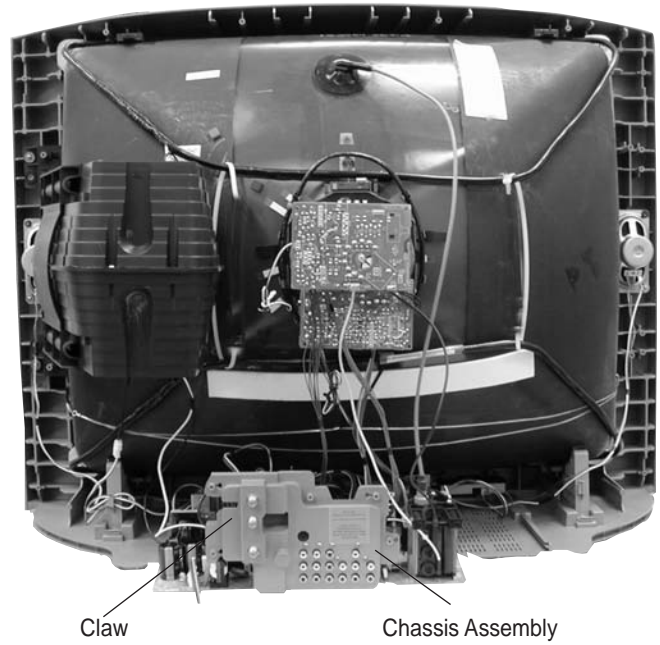

1-3. SERVICE POSITION

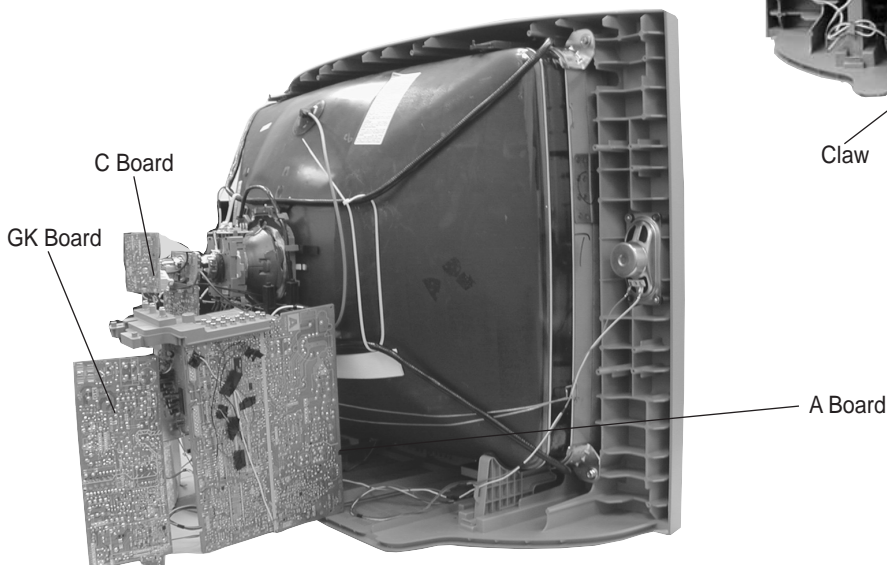

1-4. PICTURE TUBE REMOVAL

WARNING: BEFORE REMOVING THE ANODE CAP

High voltage remains in the CRT even after the power is disconnected. To avoid electric shock, discharge CRT before attempting to remove the anode cap. Short between anode and CRT coated earth ground strap.

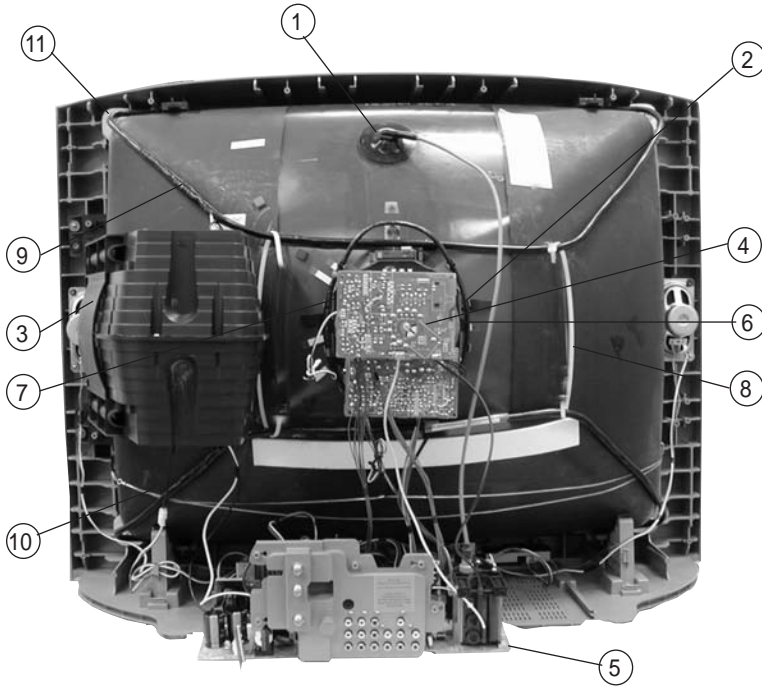
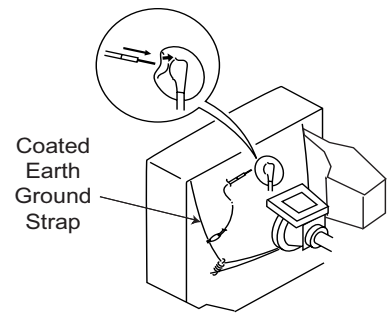

1. Discharge the anode of the CRT and remove the anode cap.
2. Unplug all interconnecting leads from the deflection yoke, neck assembly, degaussing coils and CRT grounding strap.
3. Remove the Sub-Woofer Assemblies.
4. Remove the C Board from the CRT.
5. Remove the chassis assembly.
6. Loosen the neck assembly fixing screw and remove.
7. Loosen the deflection yoke fixing screw and remove.
8. Place the set with the CRT face down on a cushion and remove the degaussing coil holders.
9. Remove the degaussing coils.
10. Remove the CRT grounding strap and spring tension devices.
11. Unscrew the four CRT fixing screws [located on each CRT corner] and remove the CRT [Take care not to handle the CRT by the neck].

ANODE CAP REMOVAL PROCEDURE

WARNING: High voltage remains in the CRT even after the power is disconnected. To avoid electric shock, discharge CRT before attempting to remove the anode cap. After removing the anode cap, short circuit to either the metal chassis, CRT shield, or carbon painted on the CRT.

NOTE: After removing the anode cap, short circuit the anode of the picture tube and the anode cap to either the metal chassis, CRT shield or carbon painted on the CRT.

REMOVAL PROCEDURES

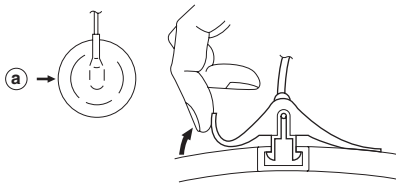

Turn up one side of the rubber cap in the direction indicated by arrow a .

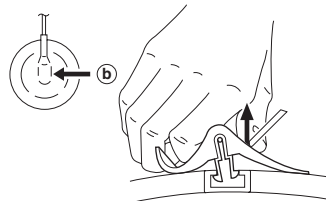

Use your thumb to pull the rubber cap firmly in the direction indicated by arrow b .

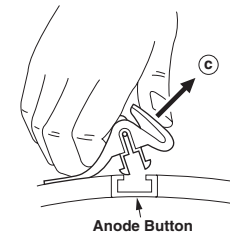

When one side of the rubber cap separates from the anode button, the anode cap can be removed by turning the rubber cap and pulling it in the direction of arrow c .

HOW TO HANDLE AN ANODE CAP

1. Do not use sharp objects which may cause damage to the surface of the anode cap.
2. To avoid damaging the anode cap, do not squeeze the rubber covering too hard. A material fitting called a shatter-hook terminal is built into the rubber.
3. Do not force turn the foot of the rubber cover. This may cause the shatter-hook terminal to protrude and damage the rubber.

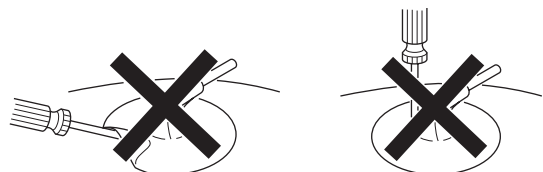

SECTION 2: SET-UP ADJUSTMENTS

The following adjustments should be made when a complete realignment is required or a new picture tube is installed. These adjustments should be performed with rated power supply voltage unless otherwise noted.

The controls and switch should be set as follows unless otherwise noted:

PICTURE CONTROL: normal
BRIGHTNESS CONTROL: normal

Perform the adjustments in order as follows:

1. Beam Landing
2. Convergence
3. Focus
4. Screen (G2)/White Balance

Test Equipment Required:

1. Color Bar Pattern Generator
2. Degausser
3. DC Power Supply
4. Digital Multimeter
5. Oscilloscope
6. CRT Analyzer

2-1. BEAM LANDING

Preparation:

- Input a white pattern signal.
- Face the picture tube in an East or West direction to reduce the influence of geomagnetism.

NOTE: Do not use the hand degausser; it magnetizes the CRT .

1. Input white pattern from pattern generator.
2. Loosen the deflection yoke mounting screw, and set the purity control to the center as shown below:

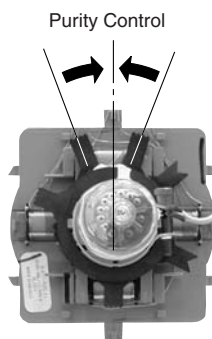

3. Input green pattern from pattern generator.
4. Move the deflection yoke backward, and adjust with the purity control so that green is in the center and red and blue are even on both sides.

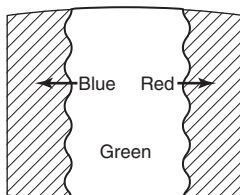

5. Move the deflection yoke forward, and adjust so that the entire screen becomes green.

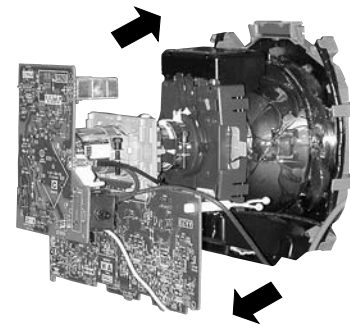

6. Switch over the raster signal to red and blue and confirm the condition.
7. When the position of the deflection yoke is determined, tighten it with the deflection yoke mounting screw.
8. When landing at the corner is not right, adjust by using the disk magnets.

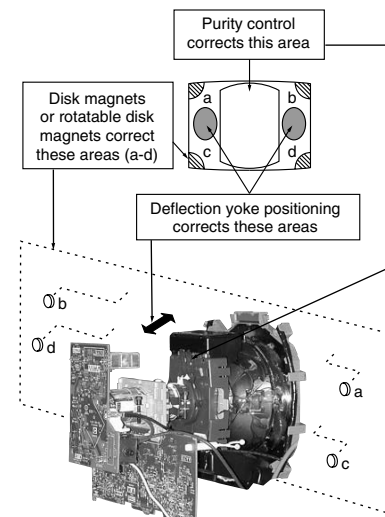

2-2. CONVERGENCE

Preparation:

- Perform FOCUS, V. LIN and V. SIZE adjustments.
- Set BRIGHTNESS control to minimum.
- Input dot pattern.

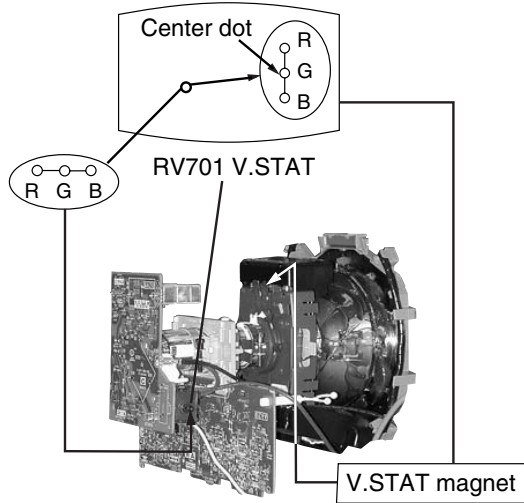

VERTICAL AND HORIZONTAL STATIC CONVERGENCE

1. Adjust V. STAT magnet to converge red, green and blue dots in the center of the screen (Vertical movement).

Tilt the V. STAT magnet and adjust static convergence to open or close the V. STAT magnet.

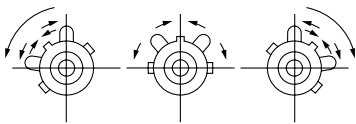

2. When the V. STAT magnet is moved in the direction of arrow a and b, red, green, and blue dots move as shown below:

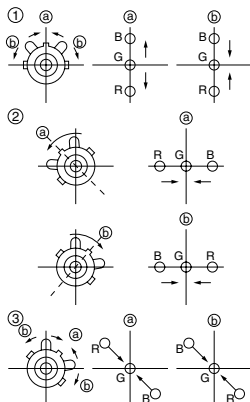

OPERATION OF BMC (HEXAPOLE) MAGNET

The respective dot positions resulting from moving each magnet interact, so perform adjustment while tracking.

- 1 Use the V.STAT tabs to adjust the red, green, and blue dots so they line up at the center of the screen (move the dots in a horizontal direction).

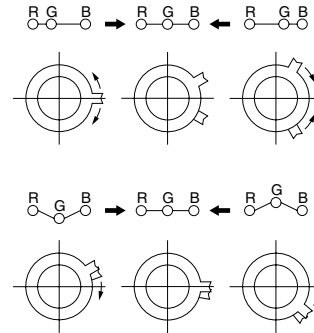

Y SEPARATION AXIS CORRECTION MAGNET ADJUSTMENT

1. Input cross-hatch pattern, adjust PICTURE to minimum and BRIGHTNESS to normal.
2. Adjust the deflection yoke upright so it touches the CRT.
3. Adjust so that the Y separation axis correction magnet on the neck assembly is symmetrical from top to bottom (open state).

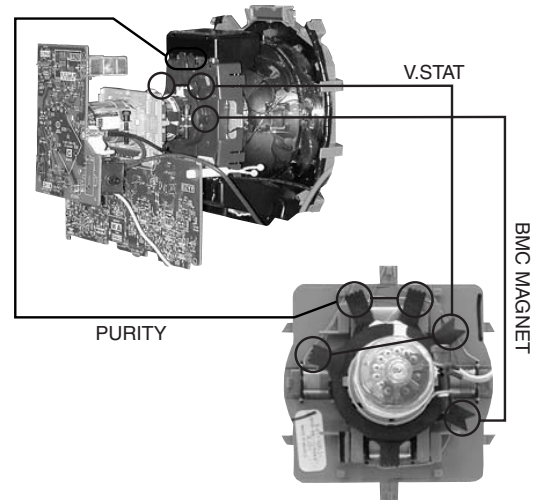

4. Return the deflection yoke to its original position.

DYNAMIC CONVERGENCE ADJUSTMENT

Before starting, perform Vertical and Horizontal Static Convergence Adjustment.

1. Slightly loosen deflection yoke screw.
2. Remove deflection yoke spacers.
3. Move the deflection yoke for best convergence as shown below:

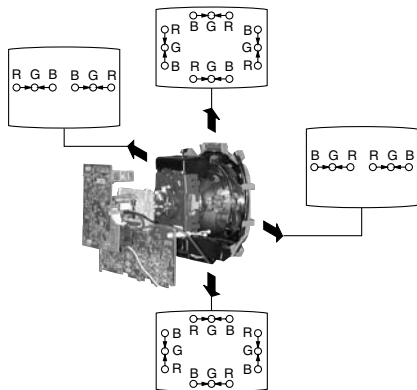

4. Tighten the deflection yoke screw.
5. Install the deflection yoke spacers.

SCREEN-CORNER CONVERGENCE

1. Affix a permalloy assembly corresponding to the misconverged areas:

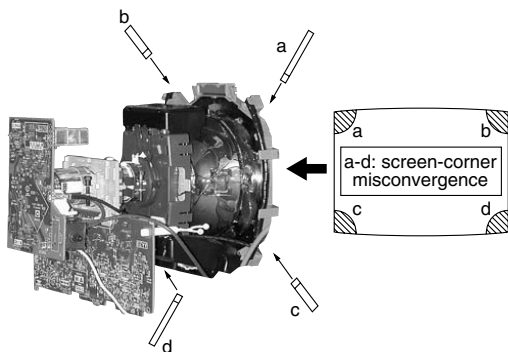

TLH PLATE ADJUSTMENT

Preparation:

- Input crosshatch pattern.
- Adjust Picture Quality to standard, Picture and Brightness to 50%, and Other to standard.
- Adjust the Horizontal Convergence of red and blue dots by tilting the TLH plate on the deflection yoke.

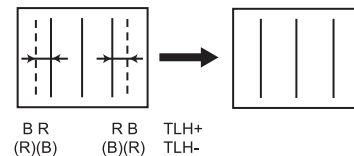
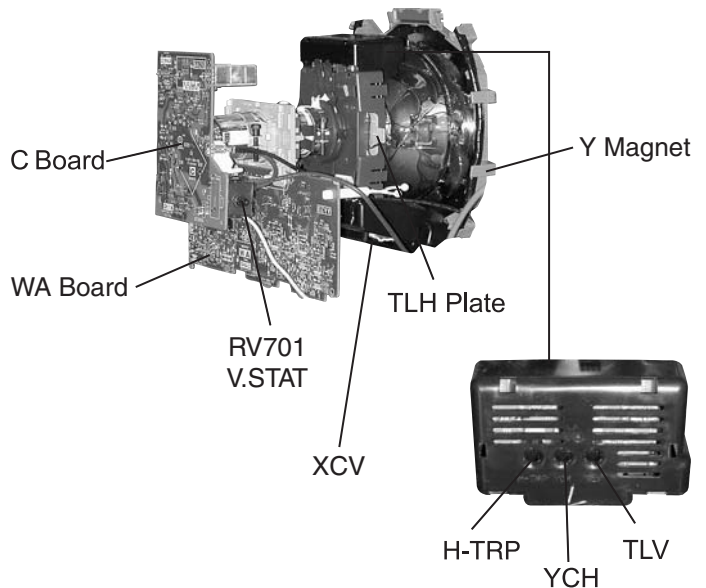

1. Adjust XCV core to balance X axis.
2. Adjust YCH VR to balance Y axis.
3. Adjust vertical red and blue convergence with V.TILT (TLV VR.) Perform adjustments while tracking items 1 and 2.
4. Adjust Y MAGNET to correct V.BOW Geometry Distortion.
5. Adjust H-TRP to correct H.Trapezoid Geometry Distortion.

After adjusting items 4 and 5, confirm overall geometry again.

2-3. FOCUS

1. Input monoscope signal.
2. Set user controls to normal.
3. Set video mode to STANDARD.
4. Set the PICTURE to maximum.
5. Adjust at 325 Mark for best center/corner focus balance.
6. Receive an entire white signal. Make sure Magenta Ring is at an acceptable level.

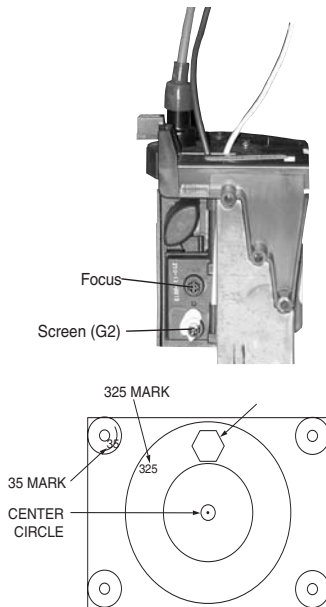

2-4. SCREEN (G2)

1. Input dot pattern from the pattern generator.
2. Set the user controls to NORMAL.
3. Attach the G2-Jig to the C Board.
4. Adjust RCUT, GCUT, BCUT, and SBRT in service mode with an oscilloscope so that voltages on the red, green, and blue cathodes are $170 \pm 2.0\text{Vdc}$.
5. Observe the screen and adjust SCREEN (G2) VR to obtain the faintly visible background of dot signal.
6. Push the TEST + JUMP (+ Channel) to cut off the signal. The screen should be bright or dark. Brightness of raster must be increased when adjusting.
7. Adjust screen VR until the screen is slightly cut off, or scarcely lights up. A signal cannot be seen when the brightness of the raster is high.
8. Push the JUMP again to release the cut off.

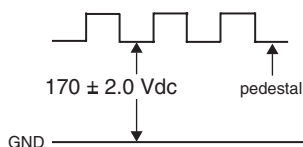

2-5. WHITE BALANCE ADJUSTMENTS

Adj.	NO.	Disp.	Item	All Models
VID_ADJ	0	RDRV	Red Drive	41
VID_ADJ	1	GDRV	Green Drive	32
VID_ADJ	2	BDRV	Blue Drive	29
VID_ADJ	3	RCUT	Red Cut-off	31
VID_ADJ	4	GCUT	Green Cut-off	14
VID_ADJ	5	BCUT	Blue Cut-off	17
VP2	4	SBRT	Sub Bright	16

1. Set program palette to STANDARD and push RESET.
2. Input an entire white signal.
3. Set to Service Adjustment Mode.
4. Set the PICTURE and BRIGHT to minimum.
5. Adjust with SBRT if necessary.
6. Set RCUT to "14".
7. Select GCUT and BCUT with **[3]** and **[5]**.
8. Adjust by pressing **[1]** and **[4]** for the best white balance.
9. Set the PICTURE and BRIGHT to maximum.
10. Select GDRV and BDRV with **[1]** and **[2]**.
11. Adjust with **[3]** and **[6]** for the best white balance.
12. Write into the memory by pressing **[3]** then **[5]**.
13. Repeat steps 1-12 for GDR4, BDR4, GCU4 and BCU4 using Video 4 input.



* Use values from Sub Contrast Adjustments

White balance should be adjusted after Sub Contrast because RDRV is also used in Sub Contrast Adjustment. (See page 22).

SECTION 3: SAFETY RELATED ADJUSTMENTS

3-1. R530, R531 CONFIRMATION METHOD (HOLD-DOWN CONFIRMATION) AND READJUSTMENTS

Always perform the following adjustments when replacing the following components marked with a  mark on the schematic diagram:

Part Replaced ()	Adjustment ()
A BOARD: R550, T503, T504, D519, IC501, R533, D521, R532, D520, C531, R529, R530, R531, C532	HV HOLD DOWN R530, R531

PREPARATION BEFORE CONFIRMATION

- Using a Variac, apply AC input voltage: 120+2.0 VAC.
- Turn the POWER switch ON.
- Input a white signal and set the PICTURE and BRIGHT controls to maximum.
- Confirm that the voltage of more than 23.0 VDC appears between TP85 and ground on the A Board.

HOLD-DOWN OPERATION CONFIRMATION

- Connect the current meter between Pin 11 of the FBT (T503) and the PWB land where Pin 11 would normally attach. (See Figure 1).
- Input a dot signal and set PICTURE and BRIGHTNESS to minimum: IABL = 2175 + 100/ -325 μ A.
- Confirm the voltage of A Board TP91 is 135 \pm 1.5 VDC.
- Connect the digital voltmeter and the DC power supply to TP85 and ground. (See Figure 1 above).
- Increase the DC power voltage gradually until the picture blanks out.
- Turn DC power source off immediately.
- Read the digital voltmeter indication (standard = 27.24 + 0.0/ - 0.1 VDC).
- Input a white signal and set PICTURE and BRIGHTNESS to maximum: IABL = 2175 + 100/ -325 μ A.
- Repeat steps 4 to 7.

HOLD-DOWN READJUSTMENT

If the setting indicated in Step 2 of Hold-Down Operation Confirmation cannot be met, readjustment should be performed by altering the resistance value of R530, R531 component marked with .

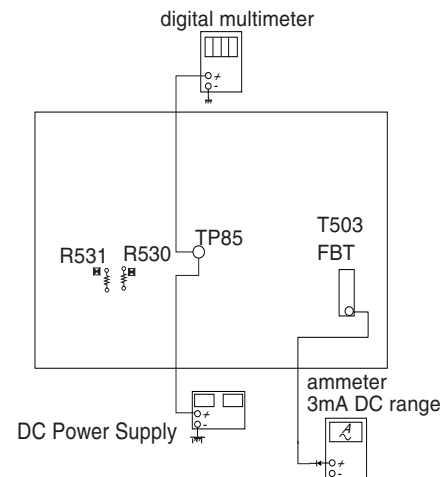



Figure 1

3-2. B+ VOLTAGE CONFIRMATION AND ADJUSTMENT

Always perform the following adjustments when replacing the following components, which are marked with  on the schematic diagram on the GK Board:

GK BOARD: IC600, PH602

- Using a Variac, apply AC input voltage: 130 + 2.0/0.0 VAC
- Input a monoscope signal.
- Set the PICTURE control and the BRIGHT control to minimum.
- Confirm the voltage on A Board between TP23 and ground is less than 136.5 VDC.
- If step 4 is not satisfied, replace R530 and R531 on A Board and repeat the above steps.

SECTION 4: CIRCUIT ADJUSTMENTS

ELECTRICAL ADJUSTMENTS BY REMOTE COMMANDER

Use the Remote Commander (RM-Y181, RM-Y182) to perform the circuit adjustments in this section.

Test Equipment Required: 1. Pattern generator 2. Frequency counter 3. Digital multimeter 4. Audio oscillator

4-1. SETTING SERVICE ADJUSTMENT MODE

- Standby mode (Power off).
- Press the following buttons on the remote commander within a second of each other:

DISPLAY → Channel **5** → Sound Volume **+** → Power

SERVICE ADJUSTMENT MODE IN

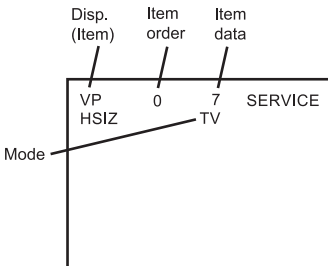

- The CRT displays the item being adjusted.
- Press **1** or **2** on the Remote Commander to select the item.
- Press **3** or **6** on the Remote Commander to change the data.
- Press **MUTING** then **ENTER** to write into memory.

SERVICE ADJUSTMENT MODE MEMORY

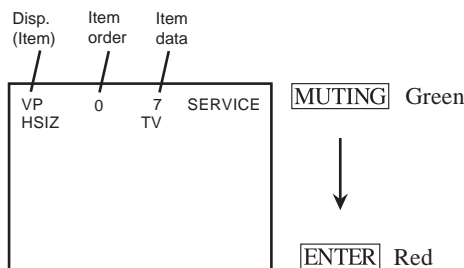

- Press then on the Remote Commander to initialize.

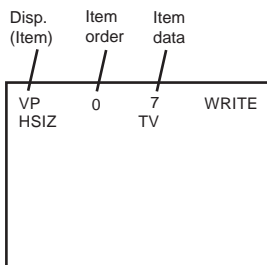

- DO NOT turn off set until **SERVICE** appears.

4-2. MEMORY WRITE CONFIRMATION METHOD

- After adjustment, pull out the plug from the AC outlet, then replace the plug in the AC outlet again.
- Turn the power switch ON and set to Service Mode.
- Call the adjusted items again to confirm they were adjusted.

4-3. REMOTE ADJUSTMENT BUTTONS AND INDICATORS

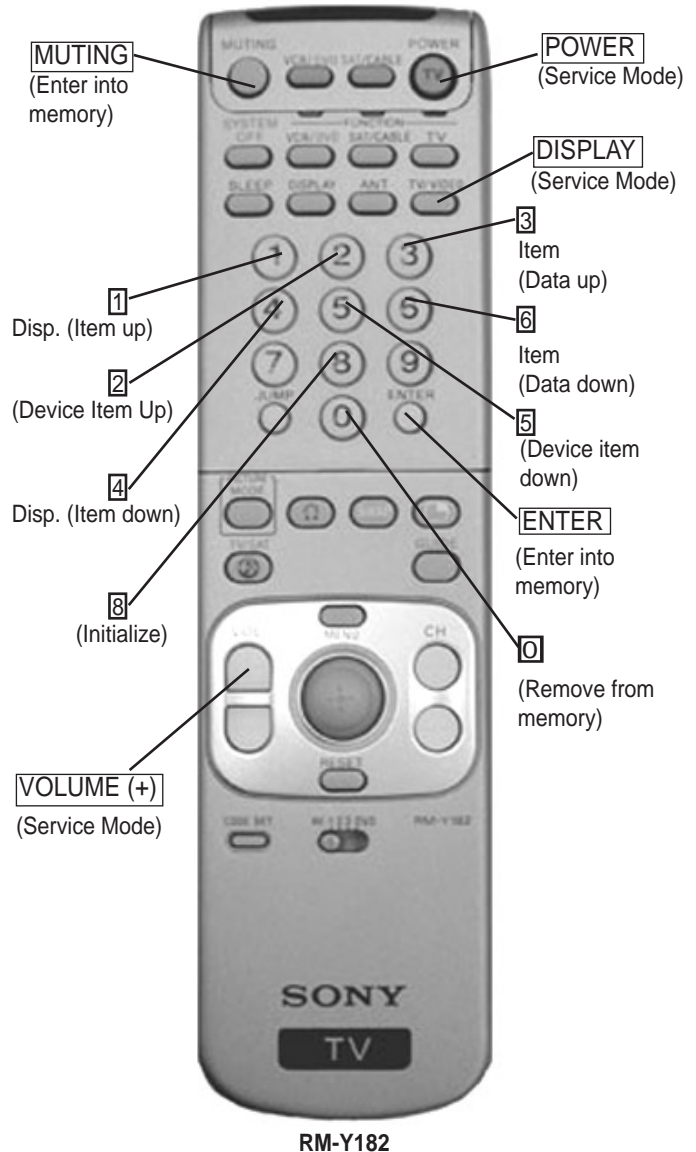

RM-Y182

4-4. SERVICE DATA LISTS

Non-Volatile Memory (NVM) Reference for BA5D Service List

Service Group	No.	Name	Description	Bit Mask	Common		
					Slave Addr	Sub Addr	Init Data
VERSION	0	VER	Microprocessor version information	11111111	=	=	0

Service Group	No.	Name	Fix / Var	Description	Bit Mask	Common				NTSC / PAL-M			PAL-N		
						Slave Addr	Sub Addr	Fix Data	Var Data	Slave Addr	Sub Addr	Data	Slave Addr	Sub Addr	Data
VP1	0	HSIZ	Var	H SIZE (11 / 2-7)	11111100					A4	A8		A4	B4	
	1	HPOS	Var	HPOS (12 / 2-7)	11111100					A4	A9		A4	B5	
	2	VBOW	Var	AFC BOW (16 / 4-7)	11110000					A4	AE		A4	BA	
	3	VANG	Var	AFC ANGLE (16 / 0-3)	00001111					A4	AE		A4	BA	
	4	VTRP	Var	TRAPEZIUM (20 / 3-7)	11111000					A4	AF		A4	BB	
	5	HTRP	Var	H. TRAPEZOID (15 / 4-7)	11110000					A4	AD		A4	B9	
	6	TROT	Fix	TILT ROTATION (0-63)	11111100					A4	A4		A4	B0	
	7	PAMP	Var	PIN AMP (13 / 2-7)	11111100					A4	AA		A4	B6	
	8	UPIN	Var	UP-CPIN (14 / 2-7)	11111100					A4	AB		A4	B7	
	9	LPIN	Var	LO-CPIN (1C / 2-7)	11111100					A4	AC		A4	B8	
	10	VSIZ	Var	V SIZE (0E / 2-7)	11111100					A4	A5		A4	B1	
	11	VPOS	Var	V POSITION (0E / 2-7)	11111100					A4	A6		A4	B2	
	12	VLIN	Var	V LINEARITY (10 / 0-3)	00001111					A4	A7		A4	B3	
	13	SCOR	Var	S CORRECTION (10 / 4-7)	11110000					A4	A7		A4	B3	
	14	VZOM	Fix	16:9 CRT Z Mode on/off	10000000	A4	85								
	15	EHT	Fix	Vertical High-Voltage Compensation	00001111	A4	80								
	16	ASP	Fix	Aspect Ratio control (4:3 Mode)	11111100	A4	FB	47							
	17	ASP1	Fix	Aspect Ratio control (16:9 Mode)	11111100	A4	FC	47							
	18	SCRL	Fix	16:9 CRT Z Mode Trans. Scroll	00111111	A4	86								
	19	HBLK	Fix	Horizontal Blanking on/off	00010000	A4	85								
	20	LBLK	Fix	Left Blanking Adjustment	11110000	A4	80								
	21	RBLK	Fix	Rigth Blanking Adjustment	00001111	A4	81								
	22	HDW	Fix	Horizontal Drive Pulse Width	00001000	A4	85								
	23	EWDC	Fix	"Parabola" EW, D.C. Adjustment	00000100	A4	88								
	24	LVLN	Fix	Lower Screen BTM Vertical Line Adj.	11110000	A4	81								
	25	UVLN	Fix	Uppe Screen BTM Vertical Line Adj.	00001111	A4	82								
	26	INTL	Fix	INTERLACE	00110000	A4	84								
	27	HOSC	Fix	Horizontal VCO Oscillation Freq.	11110000	A4	82								
	28	VSS	Fix	Vertical Sync Slice Level	11000000	A4	84								
	29	HSS	Fix	Horizontal Sync Slice Level	00001000	A4	88								
	30	HMSK	Fix	For Macro Vision	00010000	A4	88								
	31	VTMS	Fix	Select Signal VTIM Pin	01100000	A4	85								
	32	TCMD	Fix	Vertical Count Down Mode Switching (for TV)	00000011	A4	8C								
	33	VCMD	Fix	Vertical Count Down Mode Switching (for Video)	00000011	A4	8D								
	34	AFC	Fix	AFC Loop Gain Switching	11000000	A4	86								
	35	FIFR	Fix	Field Frequency	11000000	A4	87								
	36	VBLK	Fix	VBLKW	00000011	A4	88								
37	HTSW	Fix	H-Trap Switch : NEW	00100000	A4	88									

SERVICE DATA LISTS

Service Group	No.	Name	Fix / Var	Description	Bit Mask	Common				NTSC			PAL-M			PAL-N		
						Slave Addr	Sub Addr	Fix Data	Var Data	Slave Addr	Sub Addr	Data	Slave Addr	Sub Addr	Data	Slave Addr	Sub Addr	Data
VP2	0	REFP	Fix	REFP	01000000	A4	88	0										
	1	JPSW	Fix	Jump SW	00000001	=	=											
	2	SHUE	Var	Sub HUE adjustment	11110000	A4	8C											
	3	SCOL	Var	Sub COLOR adjustment	00001111					A4	8E		A4	90	7	A4	92	
	4	SBRT	Var	Sub BRIGHTNESS adjustment	00011111	A4	87											
	5	AXPL	Fix	Axis PAL	00000001	A4	89	0										
	6	AXNT	Fix	Axis NTSC	00000010	A4	89	1										
	7	CBPF	Fix	Chroma BPF on/off	00000100	A4	89	1										
	8	CTRP	Fix	Y TRAP FILTER on/off	00000001	=	=											
	9	COFF	Fix	Color On/off	00000010	=	=											
	10	KOFF	Fix	Set Color Killer	00100000	A4	89	0										
	11	SSHP	Fix	Sub SHARPNESS	11110000	A4	83											
	12	TSPF	Fix	SHARPNESS Circuit Fo (for TV)	00001100	A4	8C											
	13	VSPF	Fix	SHARPNESS Circuit Fo (for Video)	00001100	A4	8D											
	14	PREL	Fix	Pre-Shoot/ Over-Shoot	01000000	A4	89	1										
	15	ABLM	Fix	ABL Mode Switch	10000000	A4	89	1										
	16	VTH	Fix	ABL CD VHT Switching	00000001	=	=											
	17	YDEL	Fix	Y Delay Time Control	00001111	A4	84											
	18	NCOL	Fix	No Color ID	00000001	A4	85											
	19	FSC	Fix	FSC Out on/off	00000010	A4	85	1										
20	KID	Fix	Killer ID Control on/off	00000100	A4	85	0											

Service Group	No.	Name	Fix / Var	Description	Bit Mask	Common				NTSC			PAL-M			PAL-N		
						Slave Addr	Sub Addr	Fix Data	Var Data	Slave Addr	Sub Addr	Data	Slave Addr	Sub Addr	Data	Slave Addr	Sub Addr	Data
VID_ADJ	0	RDRV	var	R DRIVE (0A / 7-2)	11111100	A4	9E	41										
	1	GDRV	Var	G DRIVE (0B / 7-2)	11111100	A4	9F											
	2	BDRV	Var	B DRIVE (0C / 7-2)	11111100	A4	A0											
	3	RCUT	Var	R CUT OFF (07 / 7-2)	11111100	A4	A1	31										
	4	GCUT	Var	G CUT OFF (08 / 7-2)	11111100	A4	A2											
	5	BCUT	Var	B CUT OFF (09 / 7-2)	11111100	A4	A3											
	6	SCON	Var	Sub Contrast adjustment	00001111	A4	8A											
	7	CHUE	Var	Sub HUE adjustment for TV	00011111	A4	94	16										
	8	CCOL	Var	Sub COLOR adjustment for TV	00011111					A4	8F	18	A4	91	18	A4	93	23
	9	UOFS	Var	YUV U offset	00001111	A4	8B											
	10	VOFS	Var	YUV V offset	11110000	A4	8B											
	11	RON	Fix	R ON (01 / 3)	00001000	=	=											
	12	GON	Fix	G ON (01 / 2)	00000100	=	=											
	13	BON	Fix	B ON (01 / 1)	00000010	=	=											
	14	HUEV	Var	Sub HUE adjustment for Video	11110000	A4	8D											
15	COLV	Var	Sub COLOR adjustment for Video	11110000					A4	8E		A4	90		A4	92		

SERVICE DATA LISTS

Service Group	No.	Name	Fix / Var	Description	Bit Mask	Common		
						Slave Addr	Sub Addr	Fix Data
COL_TMP	0	GDOF	Fix	G DRIVE Offset	11111000	A4	9A	4
	1	BDOF	Fix	B DRIVE Offset	11111000	A4	9B	15
	2	GCOF	Fix	G CUT Offset	11111000	A4	9C	7
	3	BCOF	Fix	B CUT Offset	11111000	A4	9D	14
	4	DCOL	Fix	Dinamic Color	00000010	=	=	

Service Group	No.	Name	Fix / Var	Description	Bit Mask	Common		
						Slave Addr	Sub Addr	Fix Data
PIC_IMP	0	BLAD	Fix	Black area detect (01 / 6-7)	11000000	A4	09	0
	1	SRTS	Fix	SRT level (01 / 4-5)	00110000	A4	09	3
	2	YNR	Fix	YNR(01 / 2)	00000100	A4	09	1
	3	GIRE	Fix	Gamma correction(01 / 0-1)	00000011	A4	09	3
	4	DAC1	Fix	DAC1(02 / 7)	10000000	A4	0A	0
	5	DAC2	Fix	DAC2(02 / 6)	01000000	A4	0A	0
	6	VMGA	Fix	VM on 1226 (02/5-4)	00110000	A4	0A	0
	7	GCUR	Fix	Gamma curve(02 / 2)	00000100	A4	0A	1
	8	BLKC	Fix	Black Compensation (02 / 1)	00000010	A4	0A	1
	9	TEST	Fix	TEST(03 / 6-7)	11000000	A4	0B	3
	10	RS	Fix	RS (03 / 3-5)	00111000	A4	0B	0
	11	RTC	Fix	RTC(03 / 0-2)	00000111	A4	0B	2
	12	APAC	Fix	APAC	10000000	A4	0B	0
	13	SRTH	Fix	SRT bit for Dynablack = High	10000000	A4	5C	1
	14	SRTL	Fix	SRT bit for Dynablack = Low	10000000	A4	5D	1
	15	SRTO	Fix	SRT bit for Dynablack = Off	10000000	A4	5E	0
	16	SHPH	Fix	Sharpness level for Dynablack = High	01111111	A4	5C	54
	17	SHPL	Fix	Sharpness level for Dynablack = Low	01111111	A4	5D	43
18	SHPO	Fix	Sharpness level for Dynablack = Off	01111111	A4	5E	0	

Service Group	No.	Name	Fix / Var	Description	Bit Mask	Palette = VIVID			Palette = STANDARD			Palette = MOVIE			Palette = SPORTS		
						Slave Addr	Sub Addr	Fix Data	Slave Addr	Sub Addr	Fix Data	Slave Addr	Sub Addr	Fix Data	Slave Addr	Sub Addr	Fix Data
PALETTE	0	VPIC	Fix	User picture setting 0:min, 63: max	11111100	A4	5F	63	A4	65	50	A4	6B	38	A4	71	63
	1	VBRT	Fix	User brightness setting 0:min, 63: max	11111100	A4	60	31	A4	66	31	A4	6C	31	A4	72	31
	2	VCOL	Fix	User color setting 0:min, 63: max	11111100	A4	61	35	A4	67	31	A4	6D	31	A4	73	40
	3	VSHP	Fix	User sharpness setting 0:min, 63: max	11111100	A4	62	31	A4	68	31	A4	6E	34	A4	74	31
	4	VVM	Fix	0: OFF, 1: Low, 2: High, 3: N/A	00000011	A4	5F	2	A4	65	1	A4	6B	0	A4	71	2
	5	VTRI	Fix	0: Cool, 1: Nutral, 2: Warm, 3: N/A	00000011	A4	60	0	A4	66	1	A4	6C	2	A4	72	0
	6	VGMA	Fix	0: OFF, 1: Low, 2: Mid, 3: Max	00000011	A4	63	2	A4	69	2	A4	6F	2	A4	75	2
	7	VNRM	Fix	0: 3D, 1: 2D	00000010	A4	61	0	A4	67	0	A4	6D	0	A4	73	0
	8	VYDC	Fix	DC Transmission Ratio 0,1: 100%, 2: 92%, 3: 85	00000011	A4	62	3	A4	68	3	A4	6E	2	A4	74	3
	9	VVEN	Fix	Vertoca; Enhancement	00011100	A4	63	5	A4	69	3	A4	6F	3	A4	75	5
	10	VHK0	Fix	Horizontal Peaking 0:On, 1:Off	00000001	A4	61	0	A4	67	0	A4	6D	0	A4	73	0
	11	VDBK	Fix	User Dynablack 0: OFF, 1: Low, 2: High, 3: N/A	01100000	A4	63	2	A4	69	1	A4	6F	1	A4	75	1
12	VYPL	Fix	Y-Peaking Limit	00000011	A4	64	1	A4	6A	0	A4	70	0	A4	76	1	

SERVICE DATA LISTS

Service Group	No.	Name	Fix / Var	Description	Bit Mask	Common		
						Slave Addr	Sub Addr	Fix Data
3L_COMB	0	FUNN	Fix	Function (0 / 7-6) for NTSC	11000000	A4	3C	3
	1	FUNP	Fix	Function (0 / 7-6) for PAL-N, PAL-M	00110000	A5	3C	3
	2	DRNG	Fix	DRANG (0 / 2)	00000100	A4	3C	0
	3	YCSM	Fix	Y/C Sep Mode (0 / 1-0)	00000011	A4	3C	0
	4	CNRK	Fix	CNRK (1 / 7-6)	11000000	A4	3D	1
	5	CNRL	Fix	CNR Lim (1 / 5-4)	00110000	A4	3D	1
	6	CLPF	Fix	C-LPF(1 / 3)	00001000	A4	3D	1
	7	SLPF	Fix	SelC-LPF(1 / 2)	00000100	A4	3D	0
	8	MODE	Fix	Mode1 (1 / 1)	00000010	A4	3D	0
	9	YPG	Fix	Y - Peaking Gain (2 / 7-6)	11000000	A4	3E	3
	10	PDSC	Fix	Pds. Clip (2 / 3)	00001000	A4	3E	0
	11	YLPF	Fix	Y-LPF(2 / 2)	00000100	A4	3E	1
	12	VENL	Fix	V-Emph N.L (3 / 4-2)	00011100	A4	3F	4
13	VEC	Fix	V - Emph Core (3 / 1-0)	00000011	A4	3F	3	

Service Group	No.	Name	Fix / Var	Description	Bit Mask	Common		
						Slave Addr	Sub Addr	Fix Data
3D_COMB	0	COUT	Fix	COUTS(00 / 2-3)	00001100	A4	21	3
	1	YAPS	Fix	YAPS(00 / 0-1)	00000011	A4	21	1
	2	NSDS	Fix	NSDS(01 / 4-5)	00110000	A4	22	0
	3	MSS	Fix	MSS(01 / 2-3)	00001100	A4	22	0
	4	KILS	Fix	KILS (01 / 1-0)	00000011	A4	22	1
	5	DYC	Fix	DYCOS (02 / 7-6)	11000000	A4	23	2
	6	EXAD	Fix	EXADINS(02 / 5)	00100000	A4	23	0
	7	EXCS	Fix	EXCSS(02 / 1-0)	00000011	A4	23	1
	8	CPP	Fix	CPP(03 / 6)	01000000	A4	24	0
	9	HDP	Fix	HDP(03 / 3-5)	00111000	A4	24	6
	10	CDL	Fix	CDL(03 / 0-2)	00000111	A4	24	6
	11	DYCO	Fix	DYCOR(04 / 4-7)	11110000	A4	25	2
	12	DYGA	Fix	DYGAIN(04 / 0-3)	00001111	A4	25	10
	13	DCCO	Fix	DCCOR(05 / 4-7)	11110000	A4	26	2
	14	DCGA	Fix	DCGAIN(05 / 0-3)	00001111	A4	26	9
	15	YNRL	Fix	YNRLIM(06 / 4-5)	00110000	A4	27	1
	16	CNRL	Fix	CNRLIM(06 / 0-1)	00000011	A4	27	1
	17	ID1O	Fix	ID1ON(07 / 7)	10000000	A4	28	0
	18	ID1W	Fix	ID1W0A1(07 / 6)	01000000	A4	28	0
	19	ID1N	Fix	ID1W0A2(07 / 5)	00100000	A4	28	0
	20	WSC	Fix	WSC(08 / 6-7)	11000000	A4	29	1
	21	VTRH	Fix	VTRH(08 / 4-5)	00110000	A4	29	1
	22	VTRR	Fix	VTRR(08 / 2-3)	00001100	A4	29	1
	23	LDSR	Fix	LDSR(08 / 0-1)	00000011	A4	29	2
	24	WSS	Fix	WSS (09 / 7)	10000000	A4	2A	0
	25	ID1E	Fix	ID1ECON (09 / 6)	01000000	A4	2A	1
	26	TT	Fix	TT (09 / 4-5)	00110000	A4	2A	0
	27	FELC	Fix	FELCHK (09 / 3)	00001000	A4	2A	1
	28	TH	Fix	TH (09 / 1-2)	00000110	A4	2A	0
	29	VAPG	Fix	VAPGAIN(0A / 5-7)	11100000	A4	2B	3
30	VAPI	Fix	VAPINV(0A / 0-4)	00011111	A4	2B	25	

SERVICE DATA LISTS

Service Group	No.	Name	Fix / Var	Description	Bit Mask	Common		
						Slave Addr	Sub Addr	Fix Data
3D_COMB	31	YPFT	Fix	YPFT(0B / 4-5)	00110000	A4	2C	3
	32	YPFG	Fix	YPFG(0B / 0-3)	00001111	A4	2C	8
	33	V1PS	Fix	V1PS(0C / 6-7)	11000000	A4	2D	3
	34	VEGS	Fix	VEGS(0C / 4-5)	00110000	A4	2D	2
	35	CC3N	Fix	CC3N(0C / 3)	00001000	A4	2D	0
	36	C0HS	Fix	C0HS(0C / 2)	00000100	A4	2D	0
	37	SEL2	Fix	SELD2FH(0C / 0)	00000001	A4	2D	1
	38	SEL1	Fix	SELD1FL(0D / 5)	00100000	A4	2E	1
	39	YHCO	Fix	YHCOR(10 / 6-7)	11000000	A4	31	0
	40	YHCG	Fix	YHCGAIN(10 / 5)	00100000	A4	31	1
	41	OVST	Fix	+OVST(10 / 3)	00001000	A4	31	0
	42	CSHD	Fix	CSHDT(10 / 2)	00000100	A4	31	0
	43	KCTT	Fix	KCTT(10 / 0-1)	00000011	A4	31	0
	44	SHT	Fix	SHT(11 / 7-6)	11000000	A4	32	0
	45	VCT	Fix	VCT(11 / 5)	00100000	A4	32	0
	46	CGAT	Fix	CLKGAT (11 / 4)	00010000	A4	32	0
	47	CG2D	Fix	CLK2D (11 / 3)	00001000	A4	32	1
	48	CGGT	Fix	CLKGGT (11 / 2)	00000100	A4	32	0
	49	CGEB	Fix	CLKGEB (11 / 1)	00000010	A4	32	0
	50	CGT	Fix	CLKGT (11 / 0)	00000001	A4	32	0
	51	HPLL	Fix	HPLLFS(12 / 7)	10000000	A4	33	1
	52	BPLL	Fix	BPLLFS (12 / 6)	01000000	A4	33	0
	53	FSCF	Fix	FSCFG(12 / 5)	00100000	A4	33	0
	54	PLLF	Fix	PLLFG(12 / 4)	00010000	A4	33	1
	55	KILR	Fix	KILR(12 / 0-3)	00001111	A4	33	3
	56	HSSL	Fix	HSSL(13 / 4-7)	11110000	A4	34	12
	57	VSSL	Fix	VSSL(13 / 0-3)	00001111	A4	34	8
	58	BGPS	Fix	BGPS(14 / 4-7)	11110000	A4	35	4
	59	BGPW	Fix	BGPW(14 / 0-3)	00001111	A4	35	10
	60	ADCL	Fix	ADCLKS(15 / 6-7)	11000000	A4	36	3
	61	NSDW	Fix	NSDSW(15 / 4)	00010000	A4	36	1
	62	HIZE	Fix	HIZEN (16 / 4)	00010000	A4	37	0
	63	HCNT	Fix	HCNTFSYN (17 / 6)	01000000	A4	38	0

SERVICE DATA LISTS

Service Group	No.	Name	Fix / Var	Description	Bit Mask	Common		
						Slave Addr	Sub Addr	Fix Data
PIP	0	PFRN	Fix	VCXO oscilation	00000010	A4	40	0
	1	PRVS	Fix	HD/VD input synchronous mode selection	00000001	A4	40	1
	2	PCON	Fix	PIP sub contrast control	01111111	A4	41	97
	3	PUCO	Fix	PIP U level control	01111111	A4	42	5
	4	PVCO	Fix	PIP V level control	01111111	A4	43	17
	5	PHUE	Fix	PIP sub hue control	00111111	A4	57	12
	6	PKIL	Fix	Color killer	10000000	A4	42	0
	7	PSEP	Fix	C-sync sep input selection	11000000	A4	44	1
	8	PDCN	Fix	Sub pic sync sep. Thereshold setting	00110000	A4	44	3
	9	PBGS	Fix	bgp position setting	00111111	A4	45	15
	10	PDL0	Fix	Y/C delay adjust (for video)	00001111	A4	46	11
	11	PDL1	Fix	Y/C delay adjust (for yuv)	11110000	A4	46	13
	12	PBRT	Fix	Y bryghtness control	00011111	A4	48	25
	13	PVP1	Fix	V pedestal level for YUV	11110000	A4	49	0
	14	PUP1	Fix	U pedestal level for YUV	00001111	A4	49	0
	15	PVP2	Fix	V pedestal level for main w/ burst	11110000	A4	4A	0
	16	PUP2	Fix	U pedestal level for main w/ burst	00001111	A4	4A	0
	17	PVP3	Fix	V pedestal level for main w/o burst	11110000	A4	4B	0
	18	PUP3	Fix	U pedestal level for main w/o burst	00001111	A4	4B	0
	19	PACS	Fix	0D, 0Eh setting mode	01000000	A4	4C	1
	20	PSYS	Fix	Color system	00110000	=	=	
	21	PSDL	Fix	Sync delay control	00000011	A4	4C	0
	22	PCCL	Fix	YUV color level	11110000	A4	4D	11
	23	PCGA	Fix	Croma gain	00001000	A4	4D	0
24	PAAF	Fix	Auto AFC	00000100	A4	4D	1	

SERVICE DATA LISTS

Service Group	No.	Name	Fix / Var	Description	Bit Mask	Common		
						Slave Addr	Sub Addr	Fix Data
PIP	25	PSU2	Fix	For test	00000010	A4	4D	0
	26	PCVF	Fix	Internal 1H comb filter	00000001	A4	4D	0
	27	PBIT	Fix	Y clamp time constant	10000000	A4	4E	0
	28	PAFC	Fix	AFC time constant	01000000	A4	4E	0
	29	PACC	Fix	Color decoder amplitude	00111111	A4	4E	21
	30	PSDT	Fix	System automatic judgment	10000000	=	=	
	31	PBUR	Fix	VCXO mode selection	01000000	A4	4F	0
	32	PEVE	Fix	Main picture PAL-N	00100000	A4	4F	0
	33	PINW	Fix	Invert sub picture field definition	00010000	A4	4F	0
	34	PINR	Fix	Invert main picture field definition	00001000	A4	4F	0
	35	PVMD	Fix	Vertical display mode when pal-n	00000100	=	=	
	36	PREF	Fix	Main picture field fix	00000010	A4	4F	0
	37	PARE	Fix	Automatic 50/60 Hz judgement	00000001	A4	4F	0
	38	PBWD	Fix	BW det. Treshold setting	00110000	A4	50	1
	39	PFRA	Fix	Freq. Adjustment for free run mode	00001111	A4	51	0
	40	PPAL	Fix	Parameter setting for PAL-M judgment	11111111	A4	52	52
	41	PHPO	Fix	Sub picture h position	00111111	A4	58	3
	42	PVPO	Fix	Sub picture v position	00111111	A4	59	22
	43	PHTI	Fix	Display timing adjust	00001111	A4	44	3
	44	PHAJ	Fix	Main/Sub switch delay control	11110000	A4	47	2
	45	PBGY	Fix	Back ground Y level setting	00001111	A4	53	0
	46	PCRO	Fix	Sub picture read mode	10000000	A4	54	0
	47	PPAR	Fix	Thereshold contol for ident judgement of sub	00001111	A4	50	1
	48	PHPF	Fix	Y output HPF	00010000	A4	51	0
	49	PFSC	Fix	FSC output	10000000	A4	43	0
	50	PVCH	Fix	15h,16h,17h, setting mode	00000100	A4	4C	0
	51	PVON	Fix	V-chip decode mode	10000000	A4	53	1
	52	PVLN	Fix	V-chip data slicer line selection	00011111	A4	54	17
	53	PVSB	Fix	V-chip data slicer start bit detection parameter	11111111	A4	55	64
	54	PVLV	Fix	V-chip data slicer slice parameter	11111111	A4	56	130
	55	SUSW	Fix	Sub-Unlock bit position switch	01000000	A4	59	0

SERVICE DATA LISTS

Service Group	No.	Name	Fix / Var	Description	Bit Mask	KV-27FV300/29FV300				KV-32FV300/36FV300			
						Slave Addr	Sub Addr	Fix Data	Var Data	Slave Addr	Sub Addr	Fix Data	Var Data
AP	0	SBAL	Fix	Sub Balance	00000111	A8	41		4	A8	41		4
	1	SBAS	Fix	Sub Bass	00000111	A8	43		4	A8	43		4
	2	STRE	Fix	Sub Treble	00000111	A8	42		0	A8	42		0
	3	SRL	Fix	Surround level	00000001	A8	44		0	A8	44		0
	4	BBOH	Fix	Surround Off - BBE high	11110000	A8	45		10	A8	45		10
	5	BBOL	Fix	Surround Off - BBE low	00001111	A8	45		5	A8	45		5
	6	BBSH	Fix	Simulated - BBE high	11110000	A8	46		0	A8	46		0
	7	BBSL	Fix	Simulated - BBE low	00001111	A8	46		0	A8	46		0
	8	BBMH	Fix	Surround - BBE high	11110000	A8	47		0	A8	47		0
	9	BBML	Fix	Surround - BBE low	00001111	A8	47		0	A8	47		0
	10	BBGH	Fix	WOW - BBE high	11110000	A8	48		6	A8	48		6
	11	BBGL	Fix	WOW - BBE low	00001111	A8	48		9	A8	48		9
	12	BBTH	Fix	Trusurround - BBE high	11110000	A8	49		7	A8	49		7
	13	BBTL	Fix	Trusurround - BBE low	00001111	A8	49		8	A8	49		8
	14	VFIX	Fix	Audio output fix data	11111111	A8	4A		244	A8	4A		244
15	AGCL	Fix	AGC Level	00000110	A8	44		2	A8	44		2	

Service Group	No.	Name	Fix / Var	Description	Bit Mask	Common		
						Slave Addr	Sub Addr	Fix Data
CCD	0	DUM0	Fix	Only for testing	11111111	=	=	
	1	VOSD	Fix	Only for testing	00000001	=	=	

Service Group	No.	Name	Fix / Var	Description	Bit Mask	Common		
						Slave Addr	Sub Addr	Fix Data
OP	0	DISP	Fix	OSD Display position	00111111	A4	06	28
	1	RAMW	Fix		00000001	=	=	
	2	ICMP	Fix	Comparison data to determine Non-interlace signal for OSD	00011111	A4	39	4
	3	IPOR	Fix	0:Even, 1: Odd, Other: do not change	00000011	A4	3A	1
	4	FAWD	Fix	1: Forced to auto wide mode, 0:normal	00000100	A0	5D	0
	5	HCLW	Fix	H-Count Lower limit	11111111	A4	02	67
	6	HCHG	Fix	H-Count Higher limit	11111111	A4	03	254
	7	9VTM	Fix	Delay for 9V check subsystem	11111111	A4	04	55
8	ZDET	Fix	Zero detect relay delay	11111111	A4	05	123	

Service Group	No.	Name	Fix / Var	Description	Bit Mask	Slave Addr	Sub Addr	Var Data
1	ID1	Fix	Model variation ID1	11111111	A4	79	SEE ID MAP	
2	ID2	Fix	Model variation ID2	11111111	A4	7A	SEE ID MAP	
3	ID3	Fix	Model variation ID3	11111111	A4	7B	SEE ID MAP	
4	ID4	Fix	Model variation ID4	11111111	A4	7C	SEE ID MAP	
5	ID5	Fix	Model variation ID5	11111111	A4	7D	SEE ID MAP	
6	ID6	Fix	Model variation ID6	11111111	A4	7E	SEE ID MAP	
7	ID7	Fix	Model variation ID7	11111111	A4	7F	SEE ID MAP	

To determine ID's value, ID map must be referred

4-5. ID MAP TABLE

Model	Destination	ID-0	ID-1	ID-2	ID-3	ID-4	ID-5	ID-6	ID-7
KV-27FV300	US	89	63	237	98	78	128	6	16
KV-27FV300	CND	89	63	237	82	78	128	6	16
KV-29FV300	E	81	63	237	194	110	128	6	80
KV-32FV300	US	89	63	237	98	78	128	6	24
KV-32FV300	CND	89	63	237	82	78	128	6	24
KV-36FV300	US/HAW	89	63	237	98	78	128	6	24
KV-36FV300	CND	89	63	237	82	78	128	6	24

4-6. A BOARD ADJUSTMENTS

H. FREQUENCY (FREE RUN) CHECK

1. Input a TV mode (RF) with no signal.
2. Connect a frequency counter to base of Q501 (TP-25 H. DRIVE) on the A Board.
3. Check H. Frequency for $15734 \pm 400/200$ Hz.

V. FREQUENCY (FREE RUN) CHECK

1. Select video 1 with no signal input.
2. Set the conditions for a standard setting.
3. Connect the frequency counter to TP-27 (V OUT) or CN501 pin ⑥ (V DY+) and ground on the A Board .
4. Check that V. Frequency shows 60 ± 5 Hz.

SUBCONTRAST ADJUSTMENT (RDRV)

1. Input a color-bar signal and set the level to 75%.
2. Set in Standard mode.
3. Activate the Service Adjustment Mode. Set color min pic max.
4. Set GON and BON items. Using ③ and ⑥ set each to the following values. Leave RON set to "1".

Signal Type	Mode	Category	Display Item	Item Data
ntsc	service	video	rdrv	26
	vchp			00000000 00000000

R ON: ON (1)
G ON: OFF (0)
B ON: OFF (0)

5. Connect an oscilloscope probe to C Board, CN705 pin 3 (Red Out) (TP35).
6. Select SCON with ① and ④.

7. Adjust the value of SCON with ③ and ⑥ for $1.90 \pm 0.05V_{pp}$ for 27/29/32/34", or $1.95 \pm 0.05V_{pp}$ for 36/38".

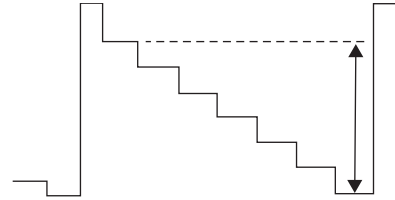

8. Reset AALS, ABLs, GON and BON values to "1".
R ON: ON (1)
G ON: ON (1)
B ON: ON (1)
9. Press [MUTING] then [ENTER] to save into the memory.

DISPLAY POSITION ADJUSTMENT (DISP)

1. Input a color-bar signal.
2. Set to Service Adjustment Mode.
3. Select DISP with ① and ④.
4. Adjust values of DISP with ③ and ⑥ to adjust characters to the center.
5. Write to memory by pressing [MUTING] then [ENTER].
6. Check to see if the text is displayed on the screen.

Signal Type	Mode	Category	Display Item	Item Data
ntsc	service	micro	disp	48
	vchp			00000000 00000000

SUB BRIGHT ADJUSTMENT (SBRT)

1. Input a monoscope signal.
2. Activate the Service Adjustment Mode.
3. Set the PICTURE and BRIGHTNESS to minimum.
4. Select the SBRT item with ① and ④.
5. Adjust the values of SBRT with ③ and ⑥ to obtain a faintly visible crosshatch.
6. Press [MUTING] then [ENTER] to save into the memory.

SUB HUE, SUB COLOR ADJUSTMENT (SHUE, SCOL)

1. Input color-bar signal at 75%.
2. Activate the Service Adjustment Mode.
3. Set (PIC) to Max and (COL) to 50%.
4. Connect an oscilloscope probe to C Board, CN705Pin ④ Blue Out.
5. Select the SHUE and SCOL item with ① and ④.

- While showing the SHUE item, adjust the waveform with **1** and **4** until the second and third bars show the same level ($V2 = V3 < 0.15V_{p-p}$).
- While showing the SCOL item, adjust the waveform with **3** and **6** until the first and fourth bars show the same level ($V1 = V4 < 0.15V_{p-p}$).

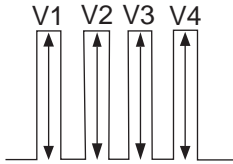

- Press **MUTING** then **ENTER** to save into the memory.

V. SIZE ADJUSTMENT (VSIZ)

- Input a crosshatch signal.
- Activate the Service Adjustment Mode.
- Select the VSIZ item with **1** and **4**.
- Adjust value of VPOS with **1** and **4** for the best vertical center.
- Press **MUTING** then **ENTER** to save into the memory.

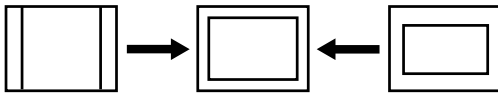

V. CENTER ADJUSTMENT (VPOS)

Perform this adjustment after performing H. Frequency (Free Run) Check.

- Input a crosshatch signal.
- Activate the Service Adjustment Mode.
- Select the VPOS item with **1** and **4**.
- Adjust value of VPOS with **3** and **6** for the best vertical center.
- Press **MUTING** then **ENTER** to save into the memory.

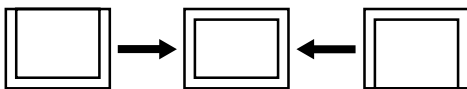

H. CENTER ADJUSTMENT (HPOS)

Perform this adjustment after performing H. Frequency (Free Run) Check.

- Input a crosshatch signal.
- Activate the Service Adjustment Mode.
- Select the HPOS item with **1** and **4**.
- Adjust the value of HPOS with **3** and **6** for the best horizontal center.
- Press **MUTING** then **ENTER** to save into the memory.

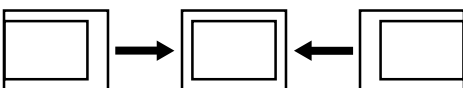

H. SIZE ADJUSTMENT (HSIZ)

- Input a monoscope signal.
- Activate the Service Adjustment Mode.
- Select HSIZ with **1** and **4**.
- Adjust with **3** and **6** for the best horizontal size.
- Press **MUTING** then **ENTER** to save into the memory.

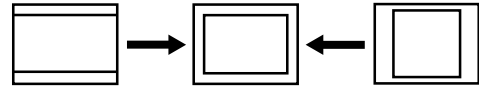

V. LINEARITY (VLIN), V. CORRECTION (SCOR), PIN AMP (PAMP), AND HORIZONTAL TRAPEZOID (HTRP) ADJUSTMENTS

- Input a crosshatch signal.
- Activate the Service Adjustment Mode.
- Select VLIN, SCOR, PAMP, and HTRP with with **1** and **4**.
- Adjust with **3** and **6** for the best horizontal size.
- Press **MUTING** then **ENTER** to save into the memory.

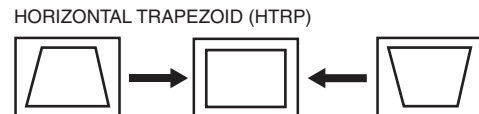
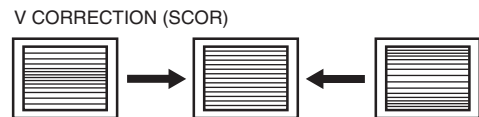
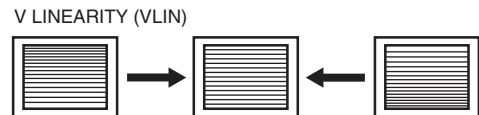

V. ANGLE (VANG), V. BOW (VBOW), UPPER PIN (UPIN) AND LOW PIN (LPIN) ADJUSTMENTS

1. Input a crosshatch signal.
2. Activate the Service Adjustment Mode.
3. Select VANG, VBOW, UPIN, and LPIN with **[1]** and **[4]**.
4. Adjust with **[3]** and **[6]** for the best picture.
5. Press **[MUTING]** then **[ENTER]** to save into the memory.

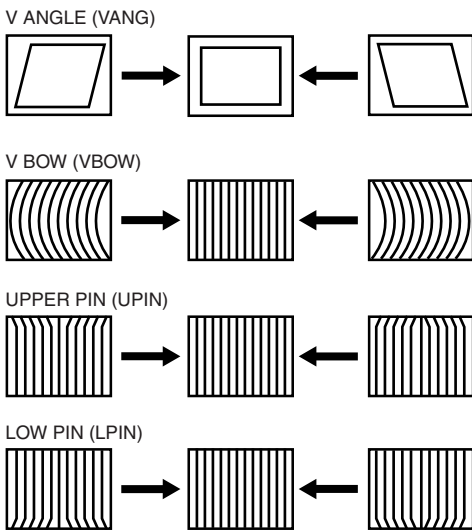

SERVICE ADJUSTMENT MODE MEMORY

1. After completing all adjustments, press **[0]** then **[ENTER]**.

Read From Memory

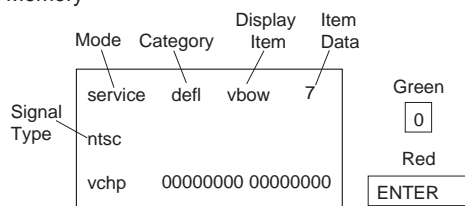

SECTION 5: DIAGRAMS

5-1. CIRCUIT BOARDS LOCATION

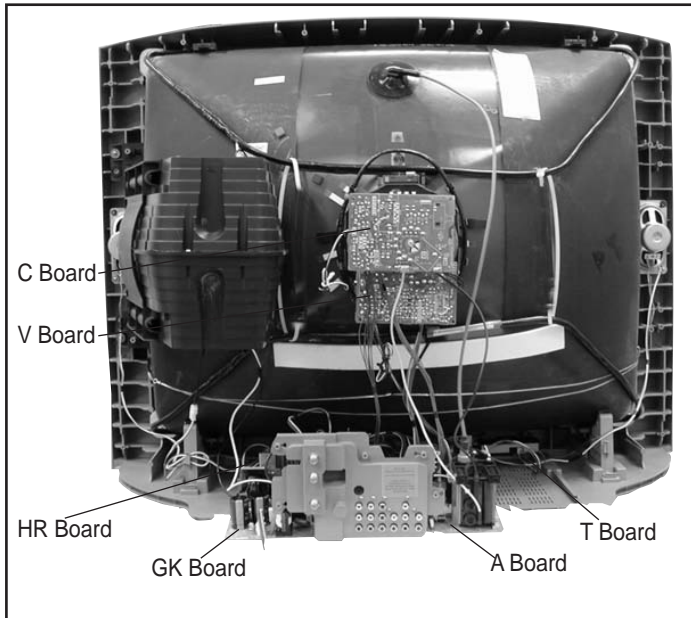

5-2. PRINTED WIRING BOARDS AND SCHEMATIC DIAGRAMS INFORMATION

All capacitors are in μF unless otherwise noted. $\text{pF} : \mu\text{F}$ 50VV or less are not indicated except for electrolytics and tantalums.

All electrolytics are in 50V unless otherwise specified.

All resistors are in ohms. $\text{k}\Omega=1000\Omega$, $\text{M}\Omega=1000\text{k}\Omega$

Indication of resistance, which does not have one for rating electrical power, is as follows: Pitch : 5mm
Rating electrical power : $\frac{1}{4}\text{W}$

$\frac{1}{4}\text{W}$ in resistance, $\frac{1}{10}\text{W}$ and $\frac{1}{8}\text{W}$ in chip resistance.

: nonflammable resistor

: fusible resistor

: internal component

: panel designation and adjustment for repair

: earth ground

: earth-chassis

All variable and adjustable resistors have characteristic curve B, unless otherwise noted.

Readings are taken with a color-bar signal input.

Readings are taken with a $10\text{M}\Omega$ digital multimeter.

Voltages are DC with respect to ground unless otherwise noted.

Voltage variations may be noted due to normal production tolerances.

All voltages are in V.

S : Measurement impossibility.

: B+line

: B-line (Actual measured value may be different).

: signal path (RF)

Circled numbers are waveform references.

The components identified by shading and are critical for safety. Replace only with part number specified.

The symbol indicates a fast operating fuse and is displayed on the component side of the board. Replace only with fuse of the same rating as marked.

Les composants identifiés par un trame et une marque sont critiques pour la sécurité. Ne les remplacer que par une pièce portant le numéro spécifié.

Le symbole indique une fusible à action rapide. Doit être remplacé par une fusible de même valeur, comme marqué.

The components identified by in this basic schematic diagram have been carefully factory-selected for each set in order to satisfy regulations regarding X-ray radiation. Should replacement be necessary, replace only with the value originally used.

When replacing components identified by , make the necessary adjustments as indicated. If the results do not meet the specified value, change the component identified by and repeat the adjustment until the specified value is achieved.

(Refer to R530 and R531 adjustment on page 16.)

When replacing the parts listed in the table below, it is important to perform the related adjustments.

Part Replaced ()	Adjustment ()
A BOARD: R550, T503, T504, D519, IC501, R533, D521, R532, D520, C531, R529, R530, R531, C532	HV HOLD DOWN R530, R531

REFERENCE INFORMATION

RESISTOR

: RN METAL FILM
 : RC SOLID
 : RPRD NONFLAMMABLE CARBON
 : FUSE NONFLAMMABLE FUSIBLE
 : RW NONFLAMMABLE WIREWOUND
 : RS NONFLAMMABLE METAL OXIDE
 : RB NONFLAMMABLE CEMENT
 : ADJUSTMENT RESISTOR

COIL

: LF-8L MICRO INDUCTOR

CAPACITOR

: TA TANTALUM
 : PS STYROL
 : PP POLYPROPYLENE
 : PT MYLAR
 : MPS METALIZED POLYESTER
 : MPP METALIZED POLYPROPYLENE
 : ALB BIPOLAR
 : ALT HIGH TEMPERATURE
 : ALR HIGH RIPPLE

5-3. BLOCK DIAGRAM AND SCHEMATICS

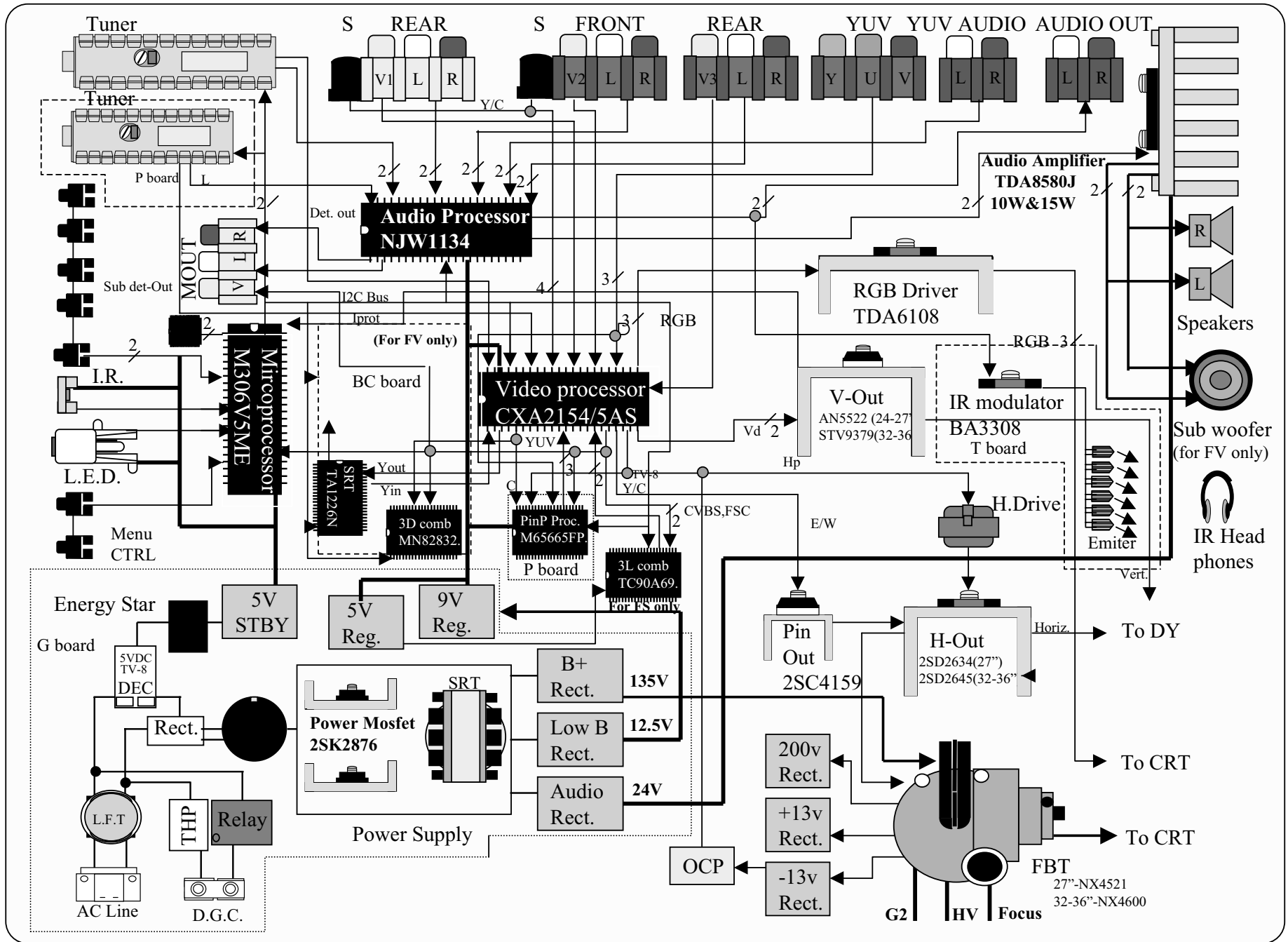

A BOARD SCHEMATIC DIAGRAM

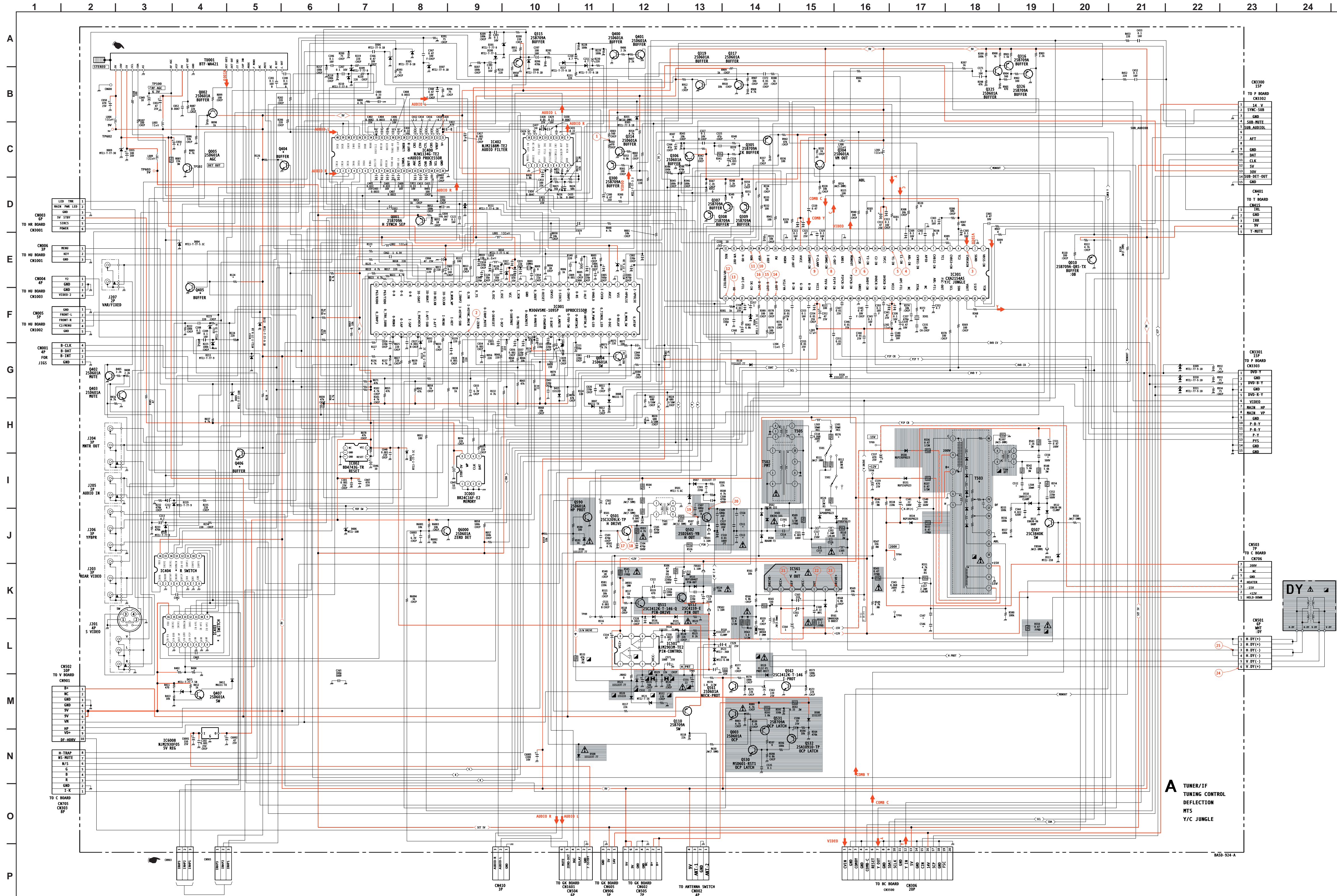

A TUNER/IF TUNING CONTROL DEFLECTION HTS Y/C JUNGLE

A

[TUNING CONTROL, DEFLECTION, TUNER/IF, Y/C JUNGLE, MTS]

1 2 3 4 5 6 7 8 9 10 11 12

A
B
C
D
E
F
G
H
I

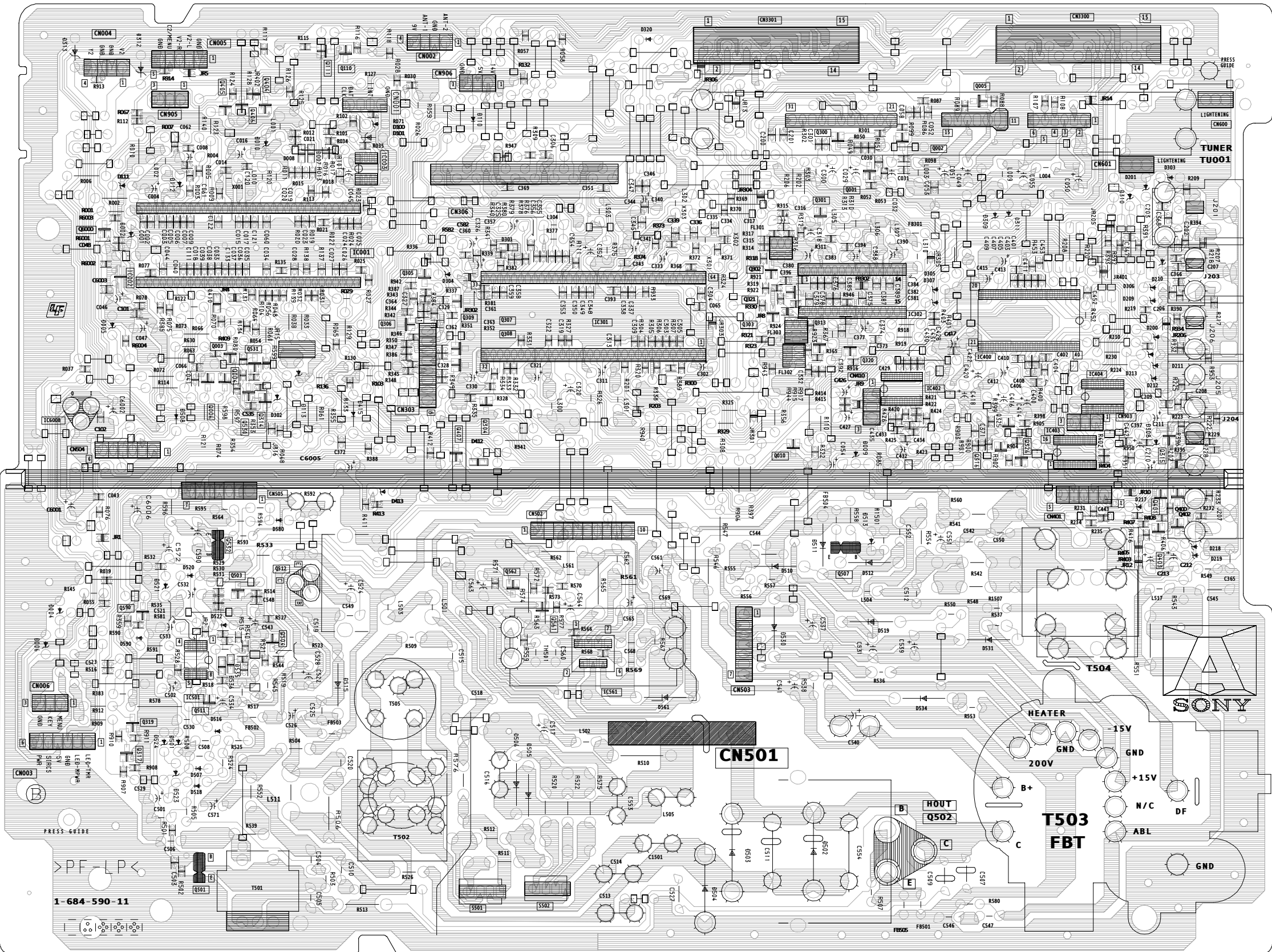

A BOARD LOCATOR LIST

DIODE		D501	G-2	TRANSISTOR	
D002	C-2	D502	H-8	Q001	B-8
D004	F-1	D503	H-7	Q002	B-9
D005	D-2	D504	I-7	Q003	D-3
D006	F-1	D505	H-5	Q004	D-3
D007	B-4	D507	H-2	Q005	A-10
D008	B-3	D508	D-2	Q010	E-8
D009	E-8	D510	F-8	Q110	A-4
D010	B-3	D511	F-8	Q111	A-4
D110	B-5	D512	F-9	Q300	B-8
D111	B-2	D513	F-9	Q304	D-5
D112	B-2	D515	G-4	Q305	C-4
D113	D-3	D516	G-3	Q306	D-4
D200	D-11	D518	H-2	Q307	C-5
D201	B-11	D519	F-9	Q308	D-5
D209	C-11	D520	F-2	Q309	C-5
D210	C-11	D521	F-2	Q314	D-3
D211	D-11	D522	F-3	Q315	E-11
D212	D-11	D523	H-2	Q316	E-10
D213	D-11	D524	G-2	Q317	G-2
D217	E-11	D530	F-8	Q319	G-2
D218	F-12	D531	F-10	Q325	E-10
D219	F-12	D534	G-9	Q326	E-10
D302	D-3	D535	G-3	Q400	E-11
D303	B-11	D536	G-3	Q401	E-11
D304	C-5	D561	G-7	Q402	E-12
D305	C-9	D580	E-3	Q403	E-11
D306	C-11	D590	F-2	Q404	A-3
D307	C-9	IC		Q405	A-3
D308	E-11	IC001	C-3	Q406	B-3
D309	B-10	IC002	C-2	Q407	E-5
D310	B-11	IC003	B-4	Q501	H-2
D311	B-10	IC301	C-6	Q502	H-9
D312	A-2	IC400	D-10	Q507	F-8
D313	A-1	IC402	D-9	Q511	G-3
D320	A-7	IC403	E-10	Q512	F-3
D410	C-2	IC404	D-11	Q530	D-3
D412	E-5	IC501	G-2	Q531	D-3
D413	E-4	IC561	G-6	Q532	F-3
D415	D-4	IC6008	D-1	Q561	F-6
				Q562	F-5
				Q590	F-2
				Q6000	C-1

A BOARD WAVEFORM

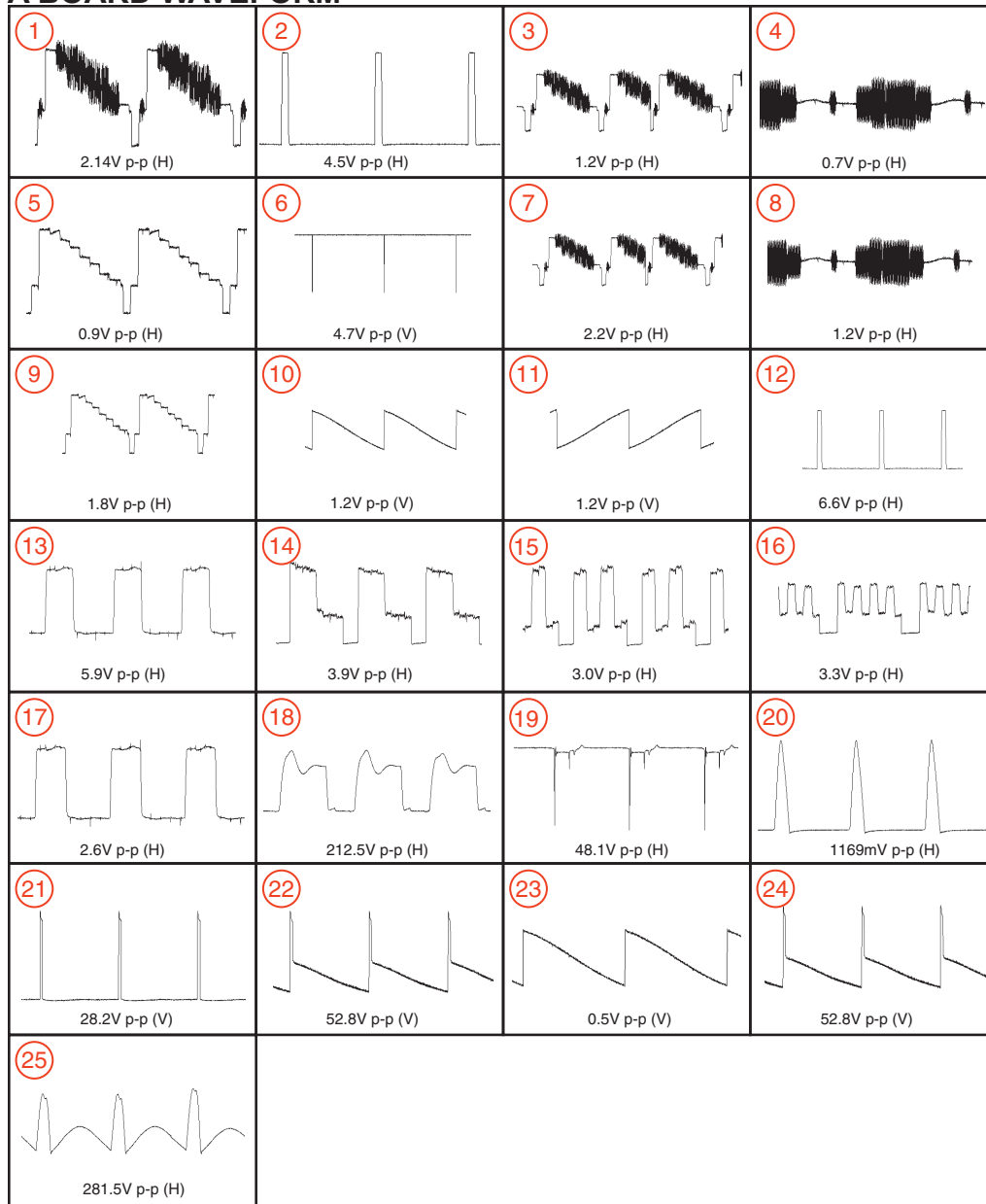

A BOARD MARK(*) LIST

REF. NO.	LOCATION	KV-27FV300 KV-29FV300	KV-32FV300	KV-36FV300
C442	K-3	#	0.22UF	0.22UF
C443	L-4	#	0.22UF	0.22UF
C511	I-13	17000PF	22000PF	22000PF
C512	I-19	0.0039UF	0.0027UF	0.0027UF
C513	J-13	0.047UF	0.051UF	0.051UF
C514	I-14	0.68UF	0.82UF	0.82UF
C516	J-15	1UF	0.82UF	0.82UF
C546	K-17	#	0.001UF	0.001UF
C547	K-17	#	0.001UF	0.001UF
C550	H-19	0.0015UF	680PF	680PF
C553	J-15	0.1UF	0.47UF	0.47UF
C554	I-13	2700PF	4700PF	4700PF
C1501	I-14	#	0.1UF	0.1UF
CN401	D-23	#	5P	5P
IC403	K-4	#	BU4051BCF-E2	BU4051BCF-E2
IC404	J-4	#	BU4051BCF-E2	BU4051BCF-E2
IC561	J-14	TDA8172	STV9379	STV9379
L505	J-15	150UH	68UH	68UH
Q404	C-5	#	2SD601A-QRS-TX	2SD601A-QRS-TX
Q405	E-4	#	2SD601A-QRS-TX	2SD601A-QRS-TX
Q406	H-5	#	2SD601A-QRS-TX	2SD601A-QRS-TX
R123	E-7	#	2.2K	2.2K
R124	E-4	#	220	220
R125	E-7	#	2.2K	2.2K
R126	C-5	#	220	220
R127	F-7	#	2.2K	2.2K
R128	G-5	#	220	220
R339	C-13	330K	39K	39K
R340	C-13	2.2M	3.3M	3.3M
R341	C-13	56K	330K	330K
R402	L-3	#	4.7K	4.7K
R404	L-4	#	4.7K	4.7K
R501	I-11	330	470	470
R504	I-12	68	560	560
R516	K-11	8.2K	5.6K	6.8K
R523	K-13	22K	12K	12K
R526	J-12	4.7	10	10
R554	I-19	15K	2.2K	#
R576	H-15	22	10	10
T503	I-18	8-598-834-20	8-598-824-10	8-598-824-10
T505	H-15	1-431-693-11	1-435-098-11	1-435-098-11

#: Not Mounted

IC BLOCK DIAGRAM

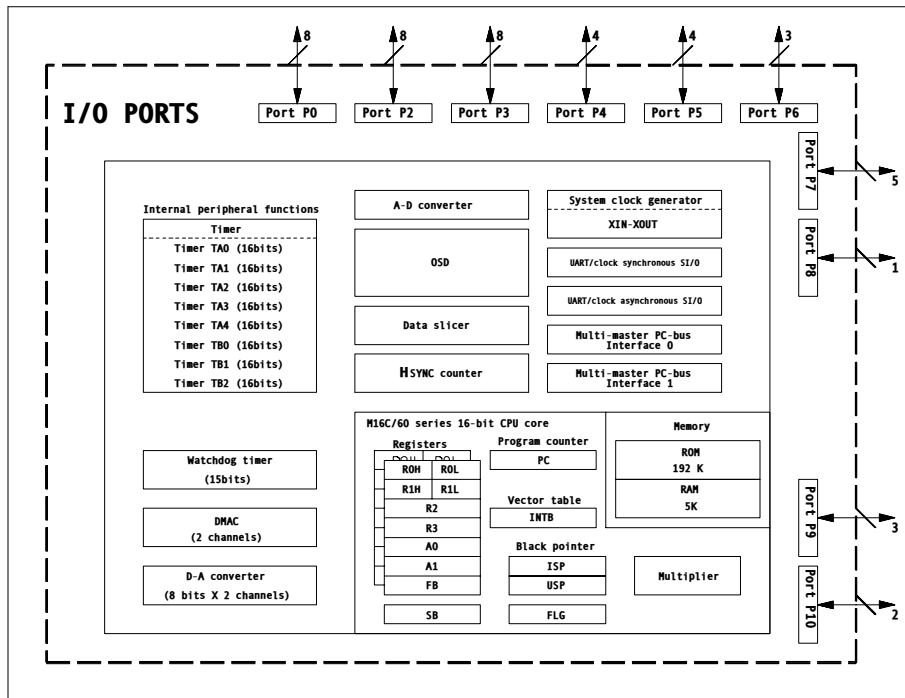

A BOARD IC VOLTAGE LIST

IC001		41	5.0	IC301		41	4.6	17	1.7	IC403		5	2.3
PIN	VOLT	42	5.0	PIN	VOLT	42	4.6	18	4.7	PIN	VOLT	6	2.5
1	4.9	43	0.2	1	5.0	43	4.6	19	4.7	1	4.5	7	-13.5
2	0.6	44	0.6	2	GND	44	9.0	20	GND	2	GND	8	12.0
3	GND	45	1.2	3	5.0	45	0.1	21	9.0	3	4.5	IC561	
4	5.0	46	4.8	4	5.0	46	4.3	22	4.4	4	0.0	PIN	VOLT
5	0.2	47	4.8	5	4.8	47	5.2	23	3.8	5	4.5	1	1.5
6	1.7	48	0.0	6	5.0	48	5.2	24	3.8	6	GND	2	12.0
7	1.4	49	0.1	7	4.8	49	GND	25	4.0	7	GND	3	-12.0
8	0.5	50	4.4	8	3.4	50	4.8	26	0.6	8	GND	4	-15.0
9	0.0	51	5.0	9	5.2	51	5.2	27	4.6	9	9.0	5	0.3
10	5.0	52	0.1	10	1.9	52	5.2	28	4.6	10	9.0	6	14.2
11	GND	53	0.0	11	0.0	53	9.1	29	4.6	11	9.0	7	1.4
12	5.0	54	4.8	12	4.8	54	5.3	30	4.6	12	4.5	IC6008	
13	2.3	55	0.1	13	9.0	55	N/C	31	4.6	13	4.5	PIN	VOLT
14	GND	56	0.0	14	0.0	56	1.7	32	4.6	14	4.5	I	7.5
15	2.1	57	4.8	15	4.8	57	N/C	33	4.6	15	4.5	O	5.0
16	5.0	58	N/C	16	4.9	58	6.9	34	4.6	16	9.0	G	GND
17	2.6	59	N/C	17	4.4	59	N/C	35	4.5	IC404		All voltages are in V.	
18	2.6	60	0.0	18	0.0	60	4.7	36	4.5	PIN	VOLT		
19	0.3	61	0.1	19	3.8	61	4.7	37	4.5	1	4.5		
20	0.0	62	4.6	20	5.5	62	4.7	38	4.5	2	GND		
21	2.1	63	0.1	21	3.6	63	1.1	39	4.5	3	0.4		
22	5.0	64	N/C	22	5.8	64	5.1	40	4.5	4	0.4		
23	5.0	IC002		23	9.0	IC400		IC402		5	4.5		
24	5.0	PIN	VOLT	24	4.4	PIN	VOLT	PIN	VOLT	6	GND		
25	5.0	1	N/C	25	0.0	1	4.5	1	GND	7	0.0		
26	5.0	2	GND	26	4.1	2	4.5	2	0.3	8	GND		
27	5.0	3	GND	27	2.4	3	4.5	3	9.0	9	9.0		
28	0.0	4	5.0	28	3.5	4	4.5	4	4.5	10	9.0		
29	0.0	5	5.0	29	3.5	5	4.5	5	4.5	11	9.0		
30	0.0	IC003		30	5.9	6	4.5	6	4.5	12	4.5		
31	N/C	PIN	VOLT	31	5.5	7	4.5	7	4.5	13	4.5		
32	N/C	1	GND	32	7.6	8	4.5	8	GND	14	4.5		
33	4.8	2	GND	33	3.6	9	4.5	9	4.5	15	4.5		
34	0.0	3	GND	34	2.8	10	4.5	10	4.5	16	9.0		
35	0.0	4	GND	35	2.5	11	4.5	11	4.5	IC501			
36	0.0	5	5.0	36	3.9	12	4.5	12	4.5	PIN	VOLT		
37	0.0	6	5.0	37	1.5	13	4.5	13	4.5	1	-13.3		
38	4.2	7	0.0	38	1.6	14	4.5	14	4.5	2	8.2		
39	1.7	8	5.0	39	1.5	15	0.6	15	4.5	3	7.2		
40	2.6			40	0.0	16	1.7	16	4.5	4	-15.0		

A BOARD TRANSISTOR VOLTAGE LIST

	B	C	E		B	C	E
Q001	0.0	0.4	5.0	Q400	0.0	0.0	GND
Q002	4.4	9.0	3.8	Q401	0.0	0.0	GND
Q003	0.7	0.0	GND	Q402	0.0	0.0	GND
Q004	0.0	4.3	GND	Q403	0.0	0.0	GND
Q005	0.1	4.9	GND	Q404	0.0	9.1	GND
Q010	4.3	GND	4.9	Q405	0.0	9.1	GND
Q110	4.8	0.0	5.0	Q406	0.0	9.1	GND
Q300	4.6	GND	5.2	Q407	0.7	0.0	GND
Q304	5.0	9.0	4.4	Q501	0.0	123.6	GND
Q305	5.0	0.0	3.4	Q502	0.0	131.8	0.0
Q306	2.0	9.0	2.3	Q507	0.3	110.7	GND
Q307	1.5	GND	2.2	Q511	-13.5	-8.4	-15.0
Q308	1.5	GND	2.2	Q512	-14.9	-2.0	-15.0
Q309	1.5	GND	2.2	Q530	0.0	4.4	GND
Q314	0.0	3.4	GND	Q531	4.4	0.0	4.4
Q315	3.4	GND	4.1	Q532	133.6	0.0	133.8
Q316	6.4	2.7	7.1	Q561	0.0	4.4	GND
Q317	0.0	3.9	GND	Q562	0.0	0.0	GND
Q319	0.6	0.6	GND	Q590	0.0	3.6	GND
Q325	2.6	6.4	1.9	Q6000	0.6	1.2	GND
Q326	2.7	GND	3.4				

All voltages are in V.

BC BOARD SCHEMATIC DIAGRAM

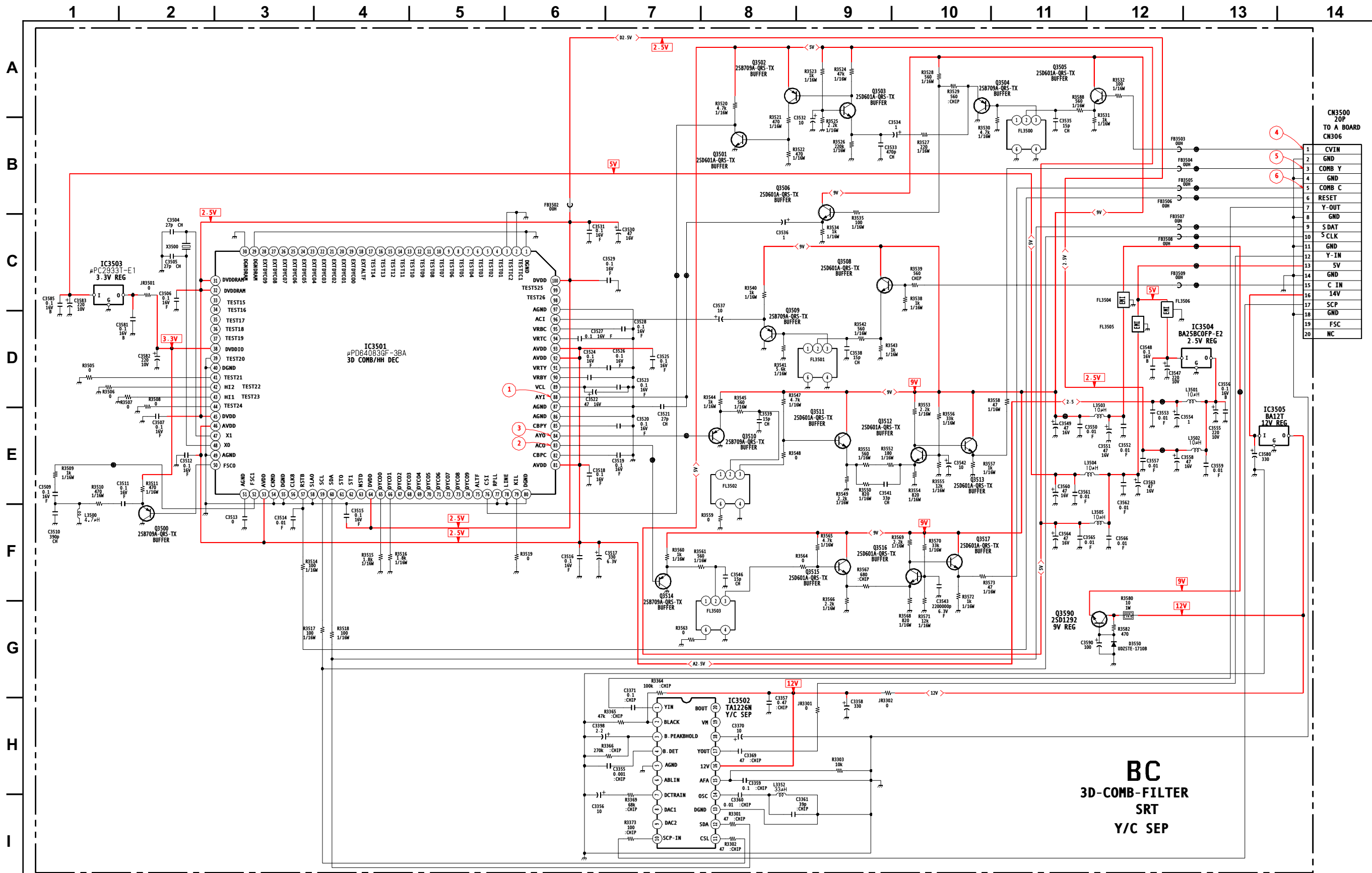

CN3500
20P
TO A BOARD
CN306

1	CVIN
2	GND
3	COMB Y
4	GND
5	COMB C
6	RESET
7	Y-OUT
8	GND
9	S DAT
10	S CLK
11	GND
12	Y-IN
13	5V
14	GND
15	C IN
16	14V
17	SCP
18	GND
19	FSC
20	NC

BC
3D-COMB-FILTER
SRT
Y/C SEP

BA5D-924-BC

BC

[3D COMB FILTER, SRT, Y/C SEP] COMPONENT SIDE

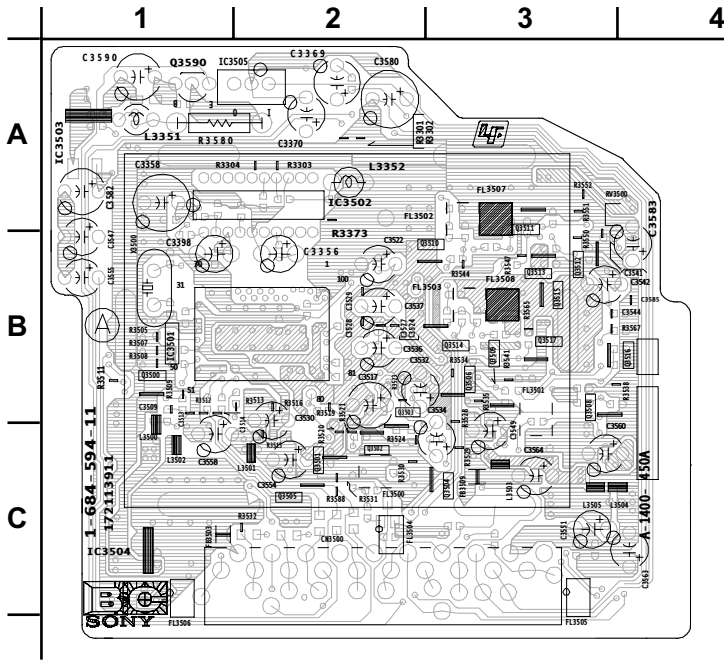

BC BOARD WAVEFORM

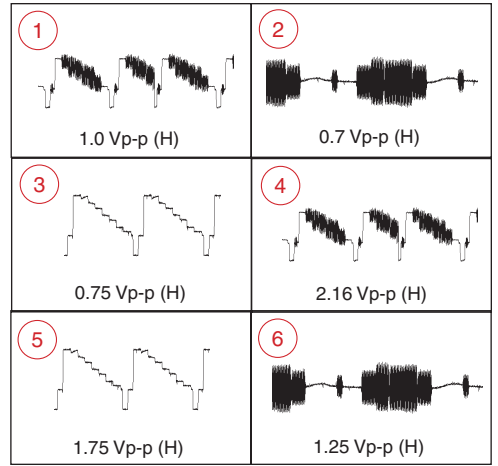

BC

[3D COMB FILTER, SRT, Y/C SEP] CONDUCTOR SIDE

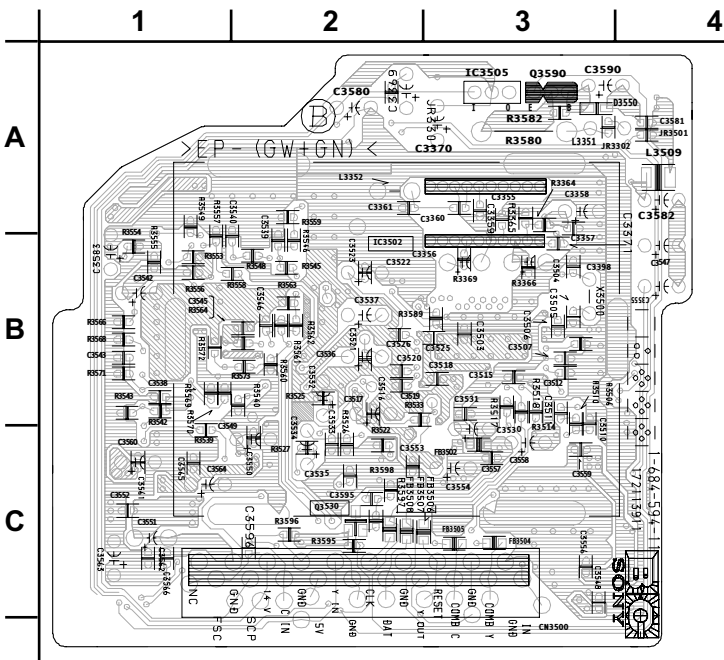

BC BOARD IC VOLTAGE LIST

IC3501		27	N/C	55	GND	83	1.4	9	N/C
PIN	VOLT	28	N/C	56	N/C	84	1.4	10	1.2
1	GND	29	GND	57	4.8	85	1.1	11	4.7
2	GND	30	GND	58	GND	86	GND	12	4.7
3	GND	31	2.5	59	4.7	87	0.0	13	0.0
4	N/C	32	2.5	60	4.7	88	1.1	14	11.5
5	N/C	33	N/C	61	N/C	89	0.7	15	4.8
6	N/C	34	N/C	62	N/C	90	0.7	16	12.0
7	N/C	35	N/C	63	N/C	91	1.3	17	0.0
8	N/C	36	N/C	64	2.5	92	2.5	18	0.5
9	N/C	37	N/C	65	0.0	93	2.5	19	N/C
10	N/C	38	3.3	66	0.0	94	0.0	20	N/C
11	N/C	39	GND	67	N/C	95	0.0	IC3503	
12	N/C	40	GND	68	N/C	96	1.1	PIN	VOLT
13	N/C	41	GND	69	N/C	97	GND	I	5.0
14	N/C	42	GND	70	N/C	98	N/C	O	3.3
15	N/C	43	GND	71	N/C	99	N/C	G	GND
16	N/C	44	GND	72	N/C	100	2.5	IC3504	
17	N/C	45	2.5	73	N/C	IC3502		PIN	VOLT
18	N/C	46	2.5	74	N/C	PIN	VOLT	I	5.0
19	N/C	47	1.3	75	N/C	1	4.7	O	2.5
20	N/C	48	1.0	76	4.2	2	3.8	G	GND
21	N/C	49	GND	77	GND	3	3.9	IC3505	
22	N/C	50	1.4	78	GND	4	4.7	PIN	VOLT
23	N/C	51	GND	79	GND	5	GND	I	14.0
24	N/C	52	1.3	80	GND	6	N/C	O	12.0
25	N/C	53	2.5	81	2.5	7	4.8	G	GND
26	N/C	54	GND	82	1.1	8	N/C	All voltages are in V.	

BC BOARD TRANSISTOR TABLE

	B	C	E		B	C	E
Q3500	1.4	GND	2.1	Q3510	2.1	GND	1.4
Q3501	4.7	4.2	GND	Q3511	2.3	9.0	2.9
Q3502	4.7	0.5	5.0	Q3512	2.5	5.7	1.9
Q3503	3.3	4.7	3.5	Q3513	5.7	9.0	5.0
Q3504	3.3	GND	4.0	Q3514	1.4	GND	2.1
Q3505	4.3	9.0	3.7	Q3515	2.9	9.0	2.3
Q3506	6.2	9.0	5.6	Q3516	2.5	6.0	1.9
Q3508	2.4	9.0	1.8	Q3517	6.0	9.0	5.4
Q3509	1.7	GND	2.3	Q3590	10.2	11.3	9.0

All voltages are in V.

HU BOARD SCHEMATIC DIAGRAM

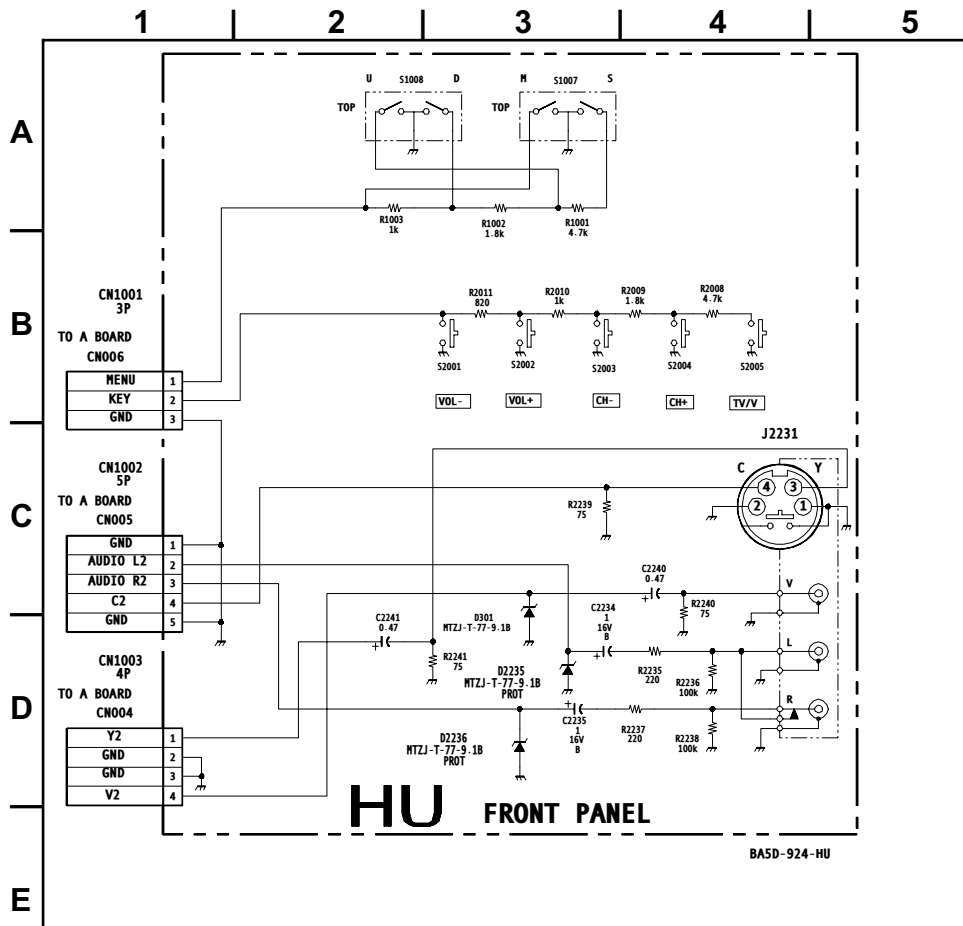

HD

[SPACER] (KV-32FV300/36FV300 ONLY)

HU

[FRONT PANEL]

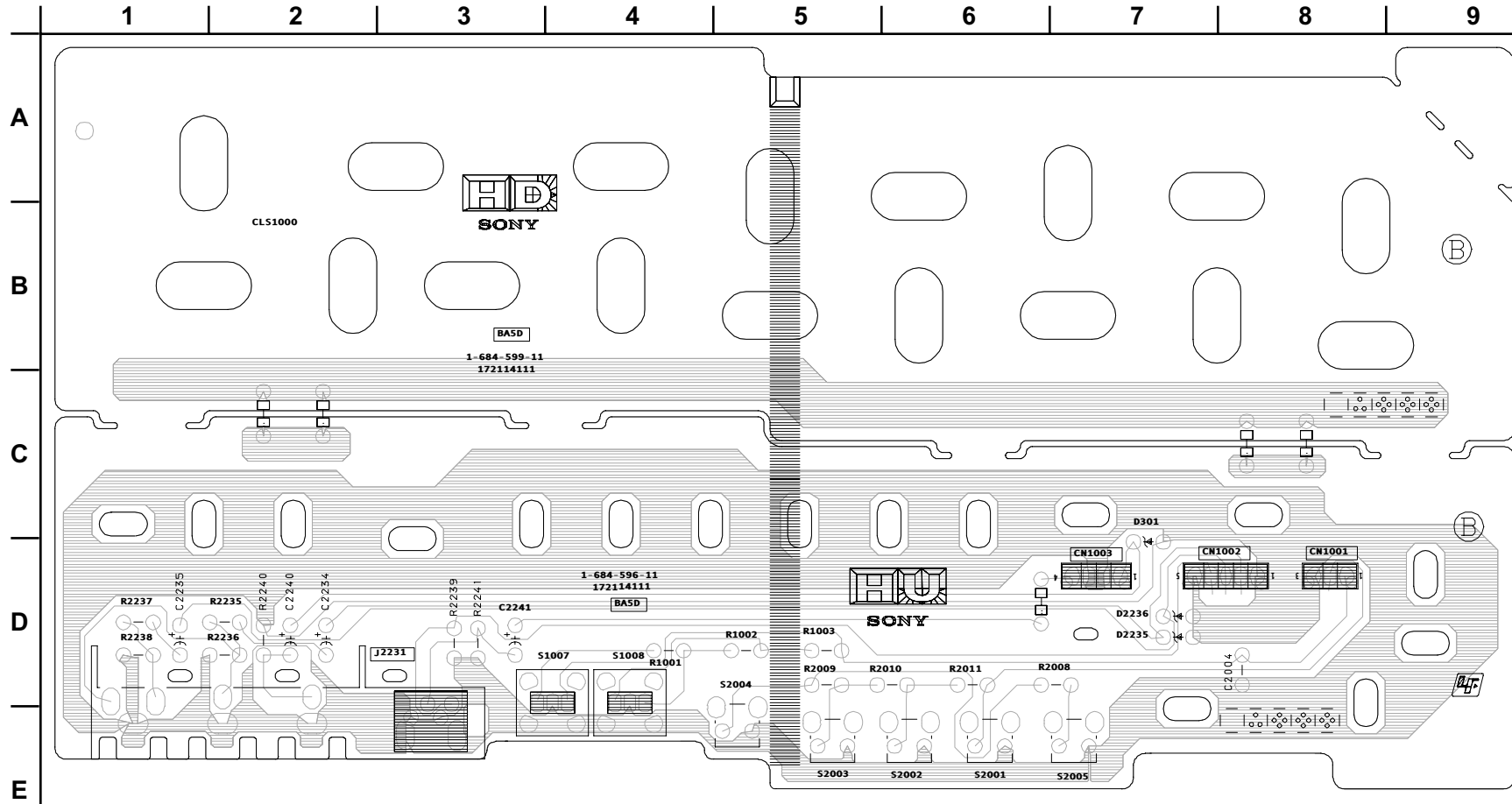

P BOARD SCHEMATIC DIAGRAM

P BOARD IC VOLTAGE LIST

IC3301		11	GND	23	GND	35	0.8
PIN	VOLT	12	GND	24	0.9	36	0.8
1	0.2	13	3.3	25	3.3	37	2.3
2	GND	14	3.2	26	3.5	38	0.8
3	4.5	15	N/C	27	2.0	39	0.8
4	4.5	16	3.3	28	1.7	40	GND
5	3.3	17	1.0	29	GND	41	0.8
6	GND	18	1.0	30	GND	42	0.6
7	N/C	19	0.5	31	GND	IC3390	
8	GND	20	0.5	32	0.6	PIN	VOLT
9	N/C	21	1.6	33	0.0	I	14.0
10	GND	22	1.0	34	3.3	O	9.0
						G	GND

All voltages are in V.

P BOARD TRANSISTOR TABLE

	B	C	E
Q151	8.4	4.5	9.0
Q152	3.9	9.0	3.2
Q3300	2.3	5.0	1.7
Q3301	1.4	5.0	0.8
Q3302	1.4	5.0	0.8
Q3304	3.9	9.0	3.3
Q3305	0.7	0.1	GND
Q3307	0.8	GND	1.5
Q3308	0.7	GND	1.4
Q3309	0.6	GND	1.3
Q3310	0.5	0.6	GND
Q3312	0.2	2.7	GND

All voltages are in V.

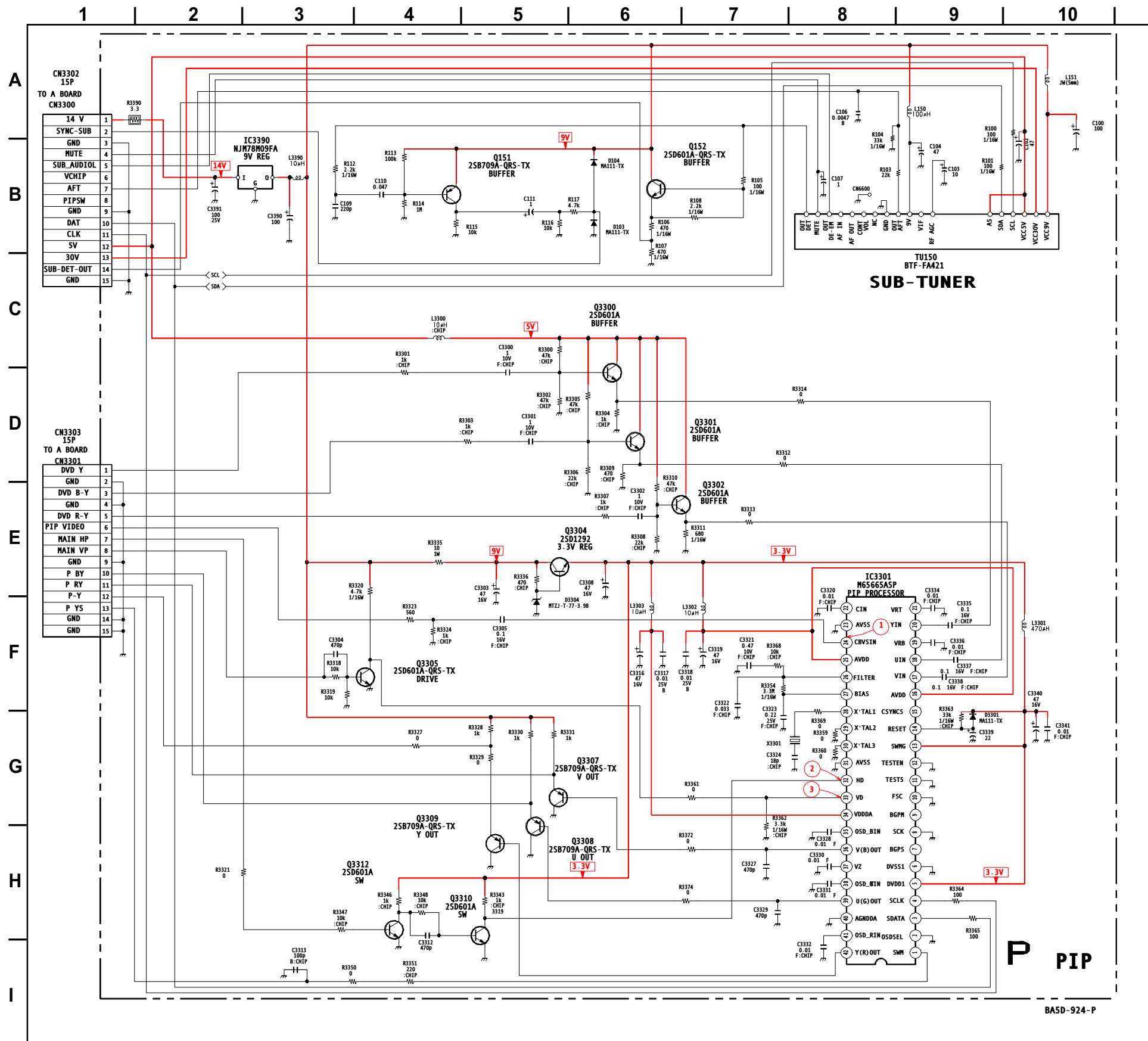

SUB-TUNER

P PIP

BA5D-924-P

P

[PIP]

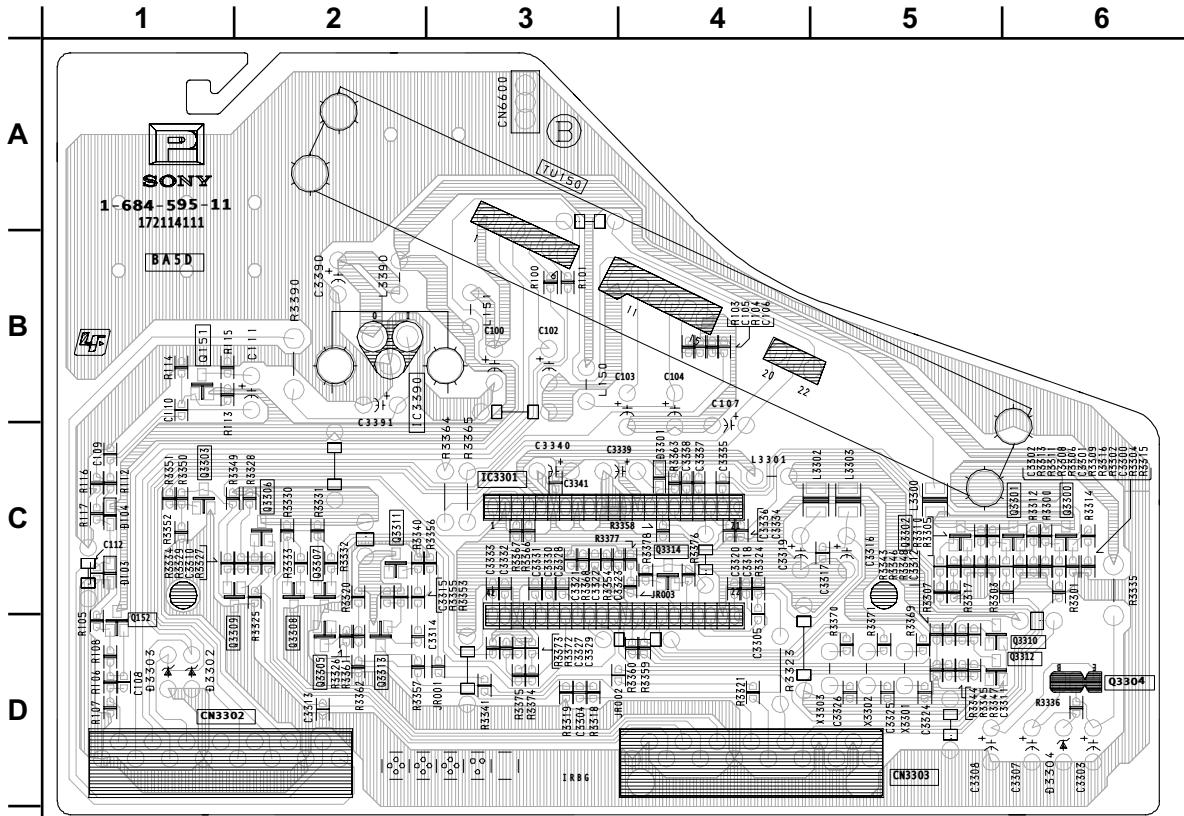

P BOARD WAVEFORM

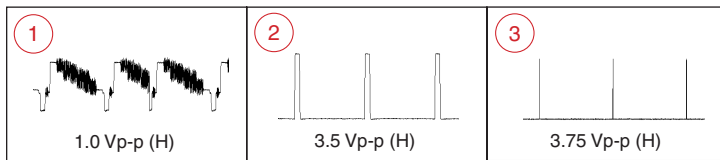

HR BOARD SCHEMATIC DIAGRAM

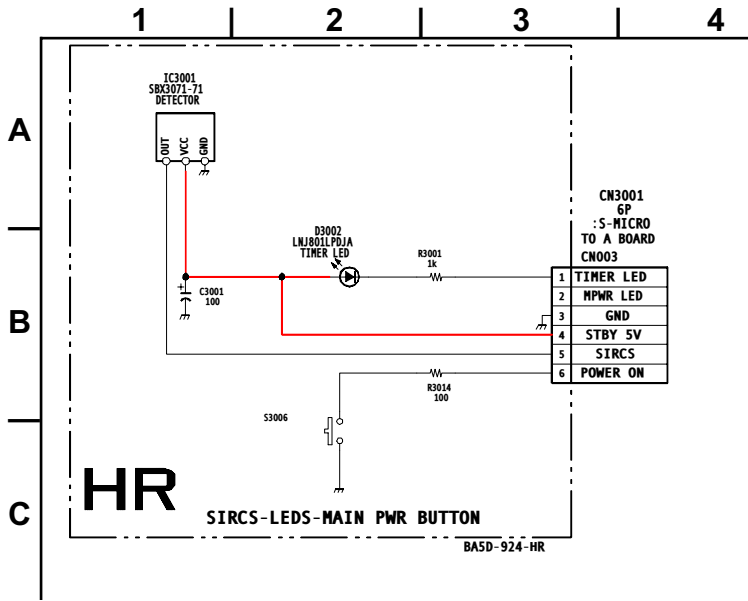

HR BOARD IC VOLTAGE TABLE

IC3001	
PIN	VOLT
1	5.0
2	5.0
3	GND
4	STBY 5V
5	SIRCS
6	POWER ON

All voltages are in V.



[SIRCS, LEDES, MAIN POWER BUTTON]

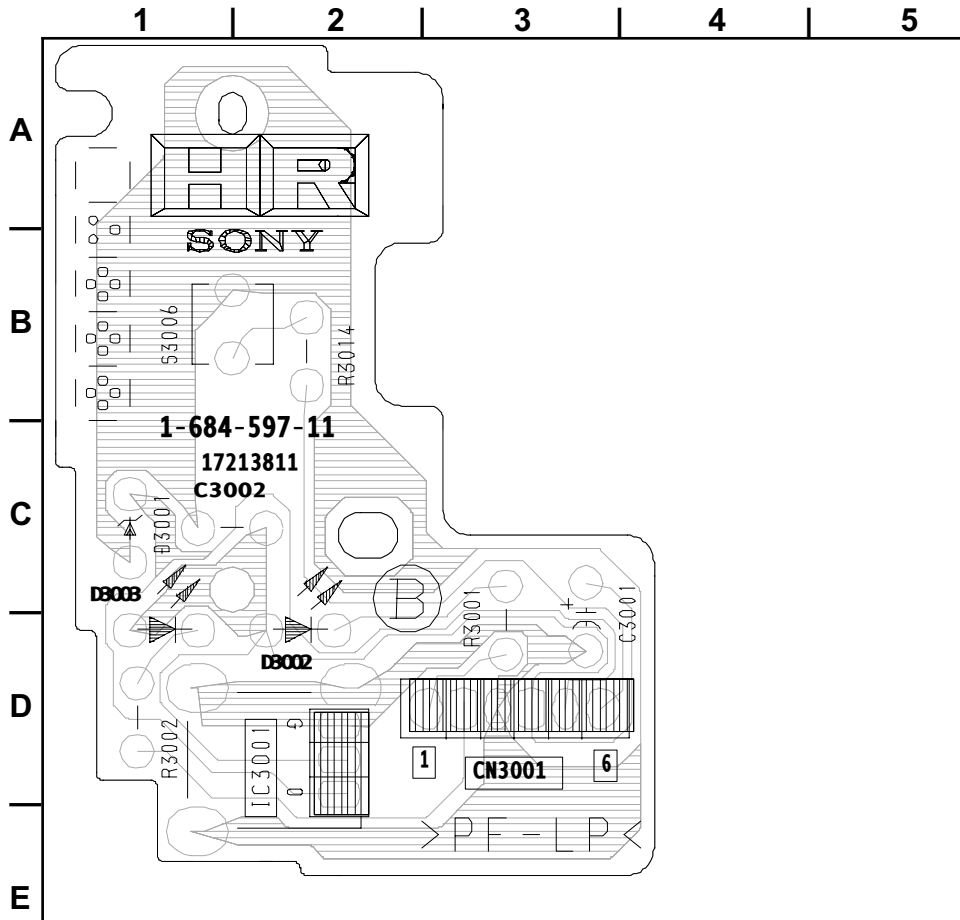

T BOARD SCHEMATIC DIAGRAM (KV-32FV300/36FV300 ONLY)

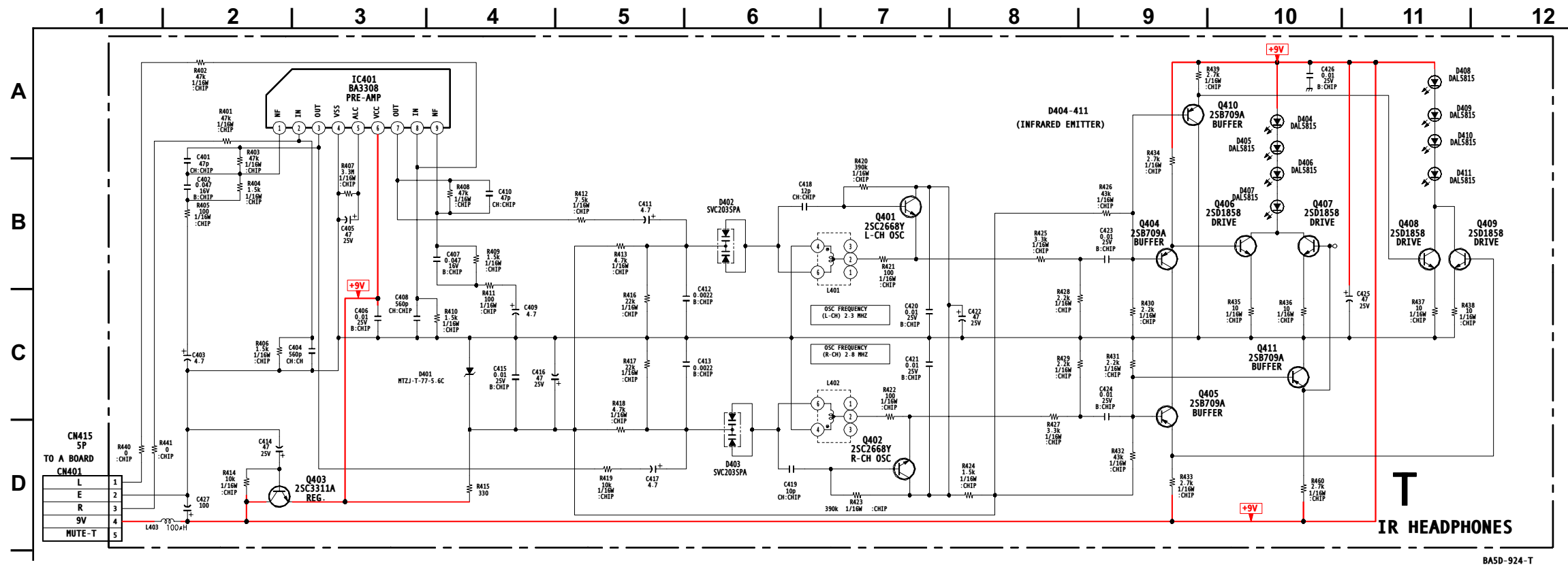

BA5D-924-T

T BOARD IC VOLTAGE TABLE

IC401	
PIN	VOLT
1	1.9
2	0.0
3	1.9
4	0.0
5	1.2
6	9.0
7	1.9
8	0.0
9	1.9

All voltages are in V.

T BOARD TRANSISTOR TABLE

	B	C	E
Q401	0.1	3.4	0.8
Q402	0.1	3.4	0.8
Q403	8.3	9.0	9.0
Q404	1.0	0.0	0.4
Q405	1.0	0.0	0.4
Q406	1.0	2.9	0.5
Q407	1.0	2.9	0.5
Q408	1.0	2.9	0.5
Q409	1.0	2.9	0.5
Q410	1.0	0.0	0.5
Q411	1.0	0.0	0.5

All voltages are in V.

T [IR HEADPHONES] (KV-32FV300/36FV300 ONLY)

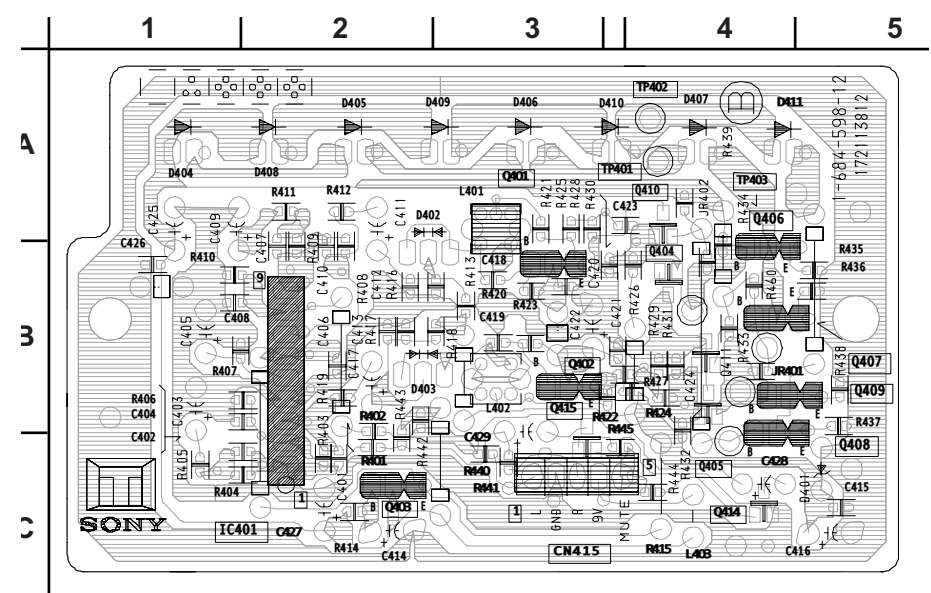

C BOARD SCHEMATIC DIAGRAM

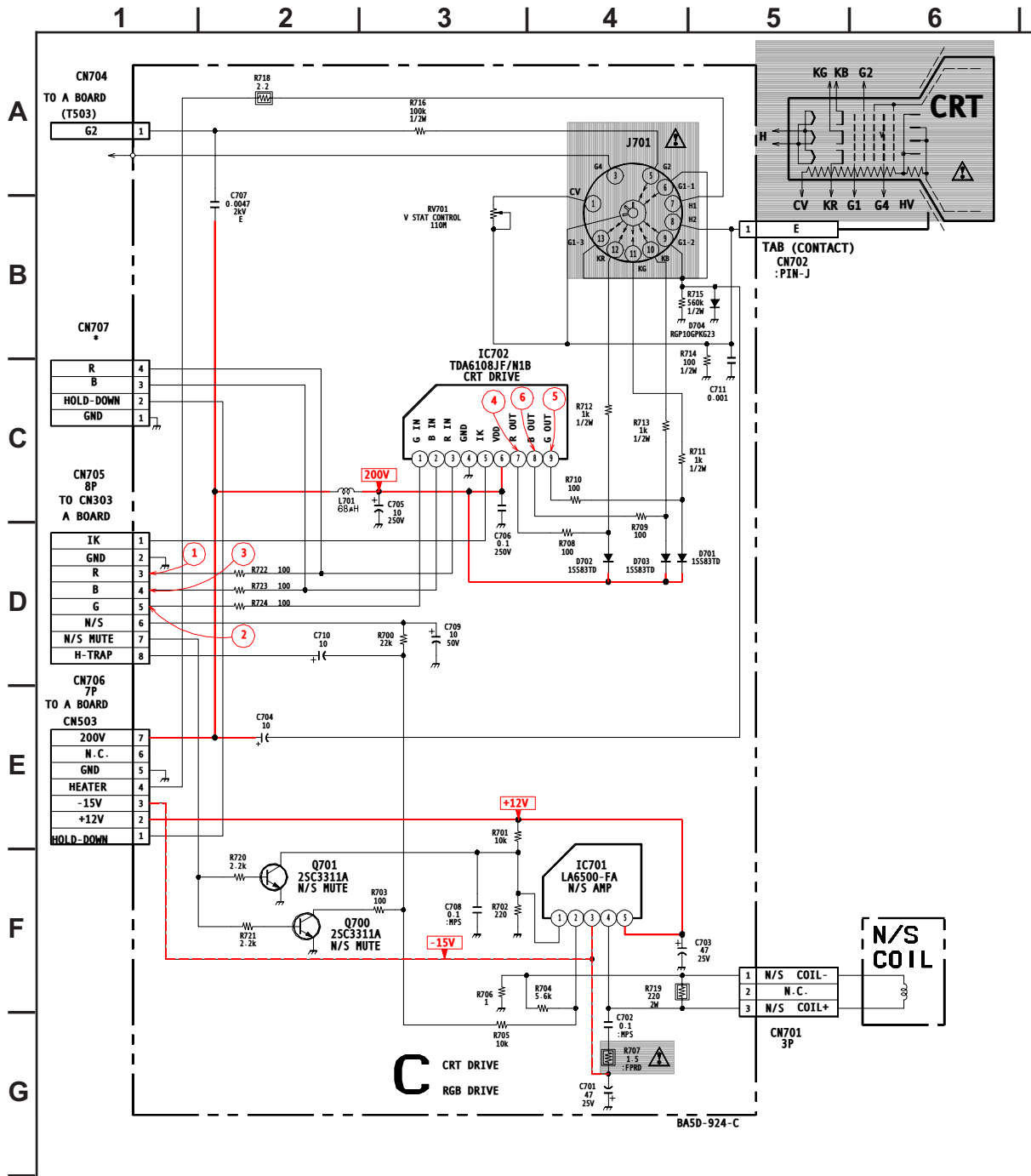

C

[RGB DRIVE, CRT DRIVE]

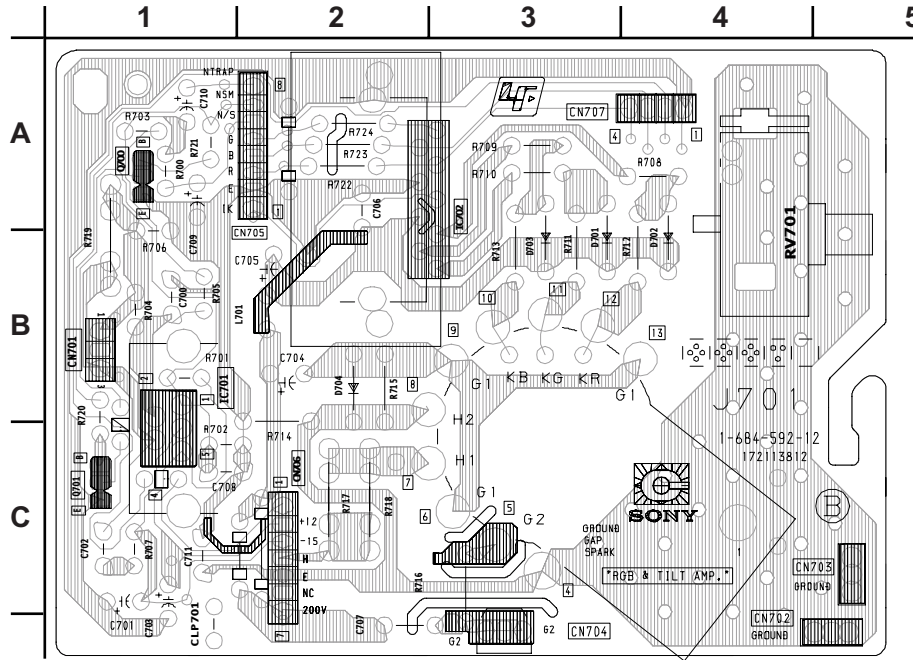

C BOARD IC VOLTAGE TABLE

IC701	
PIN	VOLT
1	0.3
2	0.3
3	-13.0
4	0.5
5	12.0
IC702	
PIN	VOLT
1	2.2
2	2.2
3	2.2
4	GND
5	5.0
6	200.0
7	139.7
8	142.0
9	138.6

All voltages are in V.

C BOARD WAVEFORM

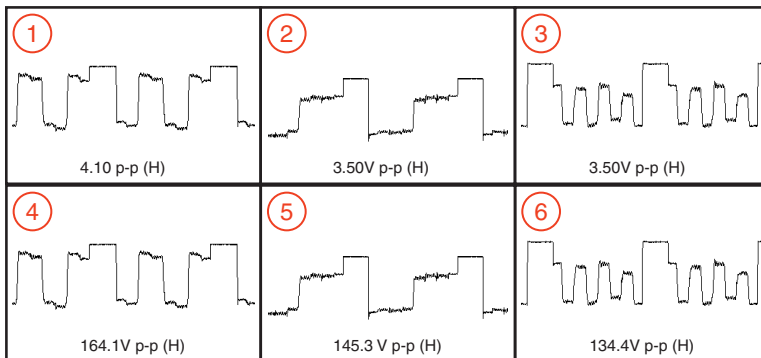

C BOARD MARK(*) LIST

REF. NO.	LOCATION	KV-27FV300 KV-29FV300 KV-32FV300	KV-36FV300
CN707	B-1	#	4P

#: Not Mounted

C BOARD TRANSISTOR TABLE

	B	C	E
Q700	0.3	0.8	GND
Q701	0.3	0.3	GND

All voltages are in V.

V BOARD SCHEMATIC DIAGRAM

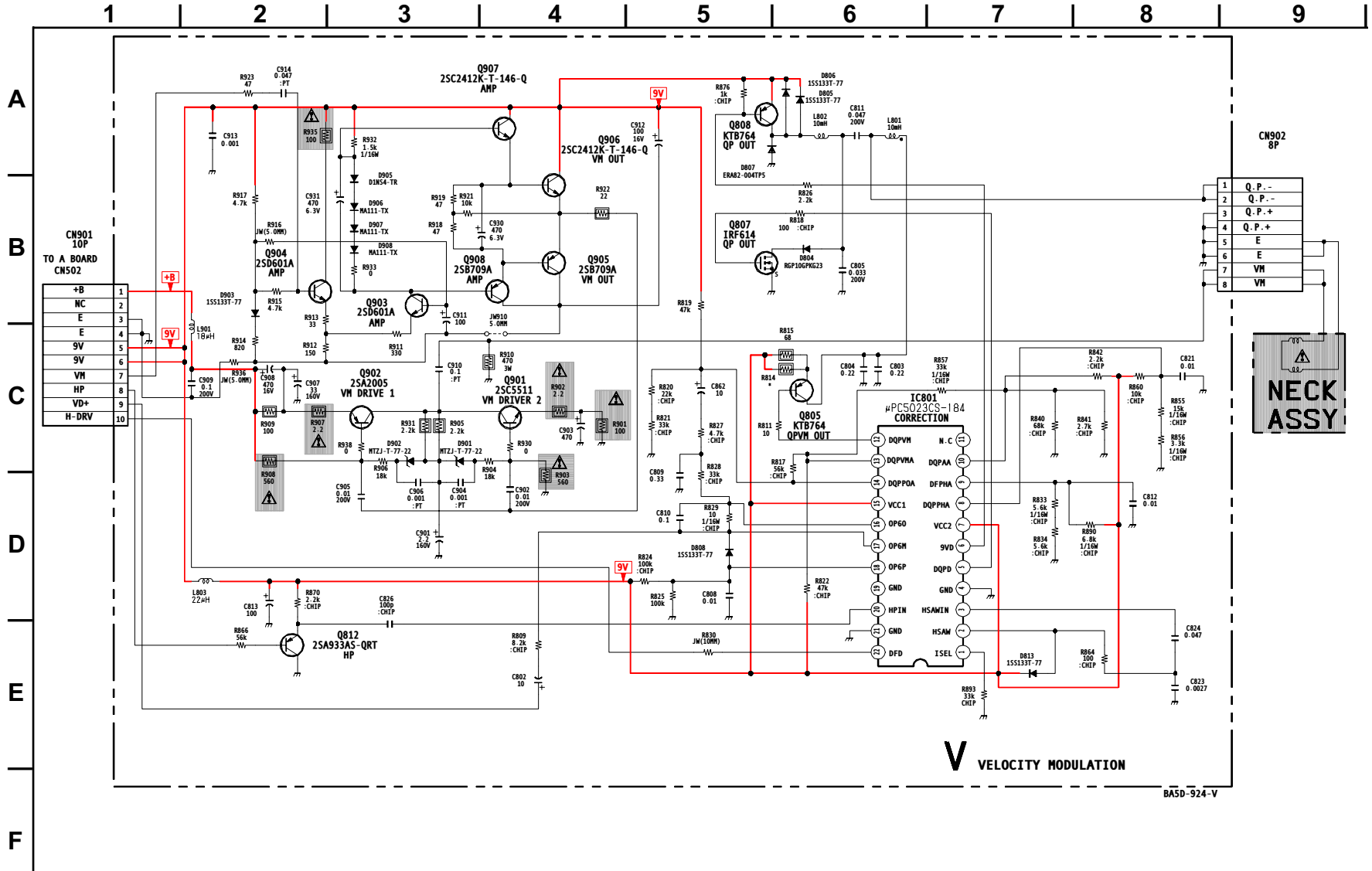

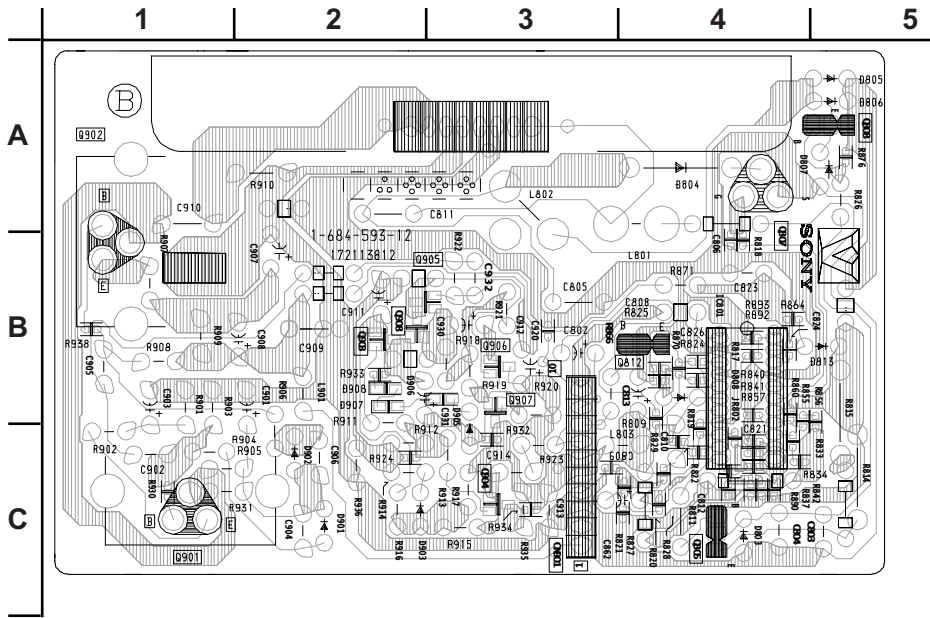

[VELOCITY MODULATION]

**V BOARD MARK(*) LIST**

REF. NO.	LOCATION	KV-27FV300	KV-32FV300
		KV-29FV300	KV-36FV300
R814	C-6	#	68 1W

V BOARD IC VOLTAGE LIST

IC801		11	N/C
PIN	VOLT	12	3.5
1	7.4	13	3.8
2	2.3	14	4.5
3	4.8	15	9.0
4	GND	16	4.6
5	6.3	17	4.6
6	4.5	18	4.5
7	9.0	19	N/C
8	5.8	20	4.8
9	4.6	21	GND
10	4.8	22	0.3

All voltages are in V.

V BOARD TRANSISTOR TABLE

	B	C	E
Q805	3.5	1.8	4.2
Q808	8.6	4.3	9.0
Q812	1.3	GND	2.0
Q901	1.4	67.0	0.8
Q902	132.9	67.0	133.4
Q903	1.2	6.2	1.8
Q904	1.2	8.8	1.8
Q905	7.1	0.0	6.7
Q906	7.4	9.0	7.1
Q907	7.4	9.0	8.1
Q908	6.9	0.0	6.2

	D	G	S
Q807	9.5	6.3	GND

All voltages are in V.

GK BOARD SCHEMATIC DIAGRAM

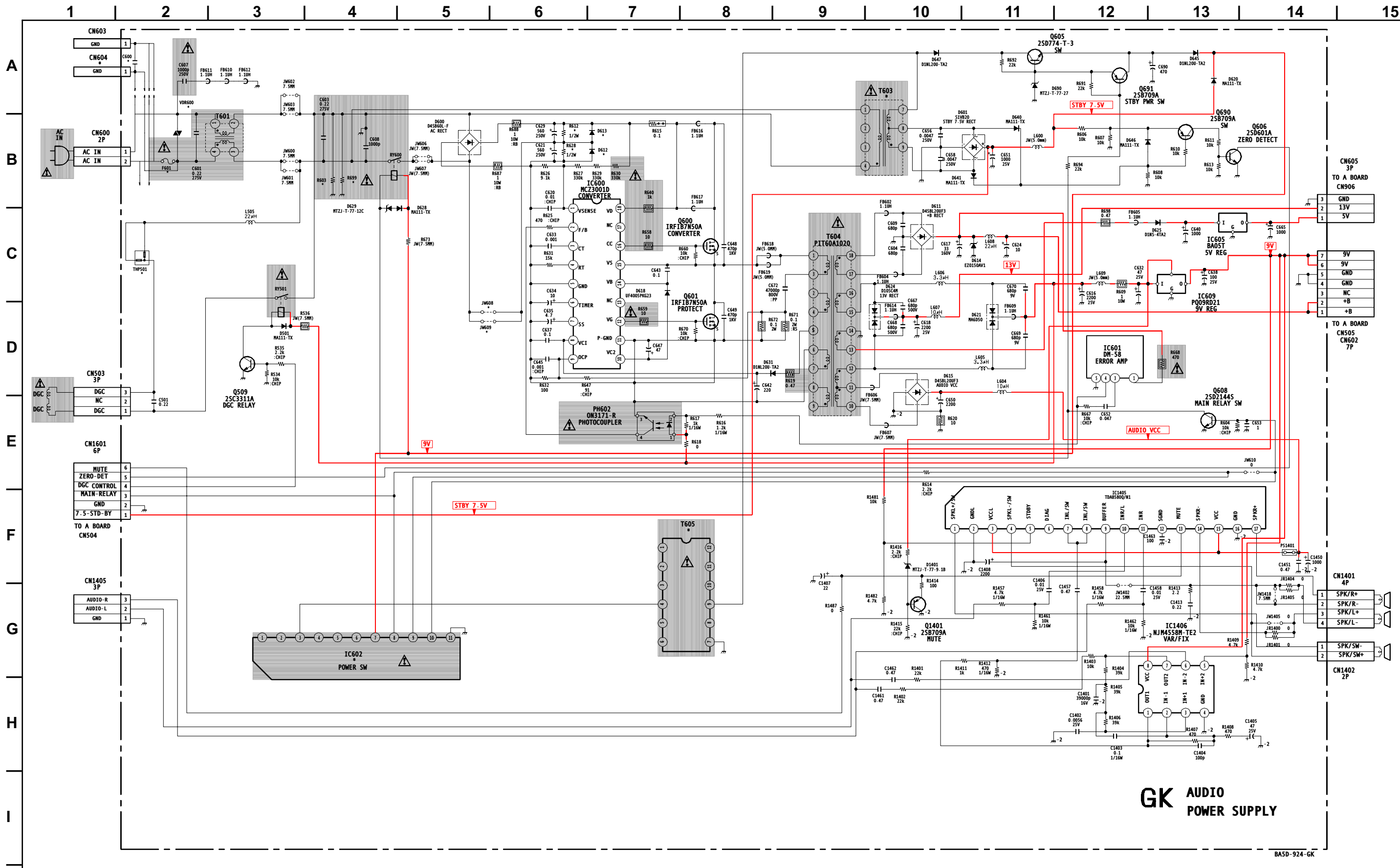

GK AUDIO POWER SUPPLY

BASD-924-GK

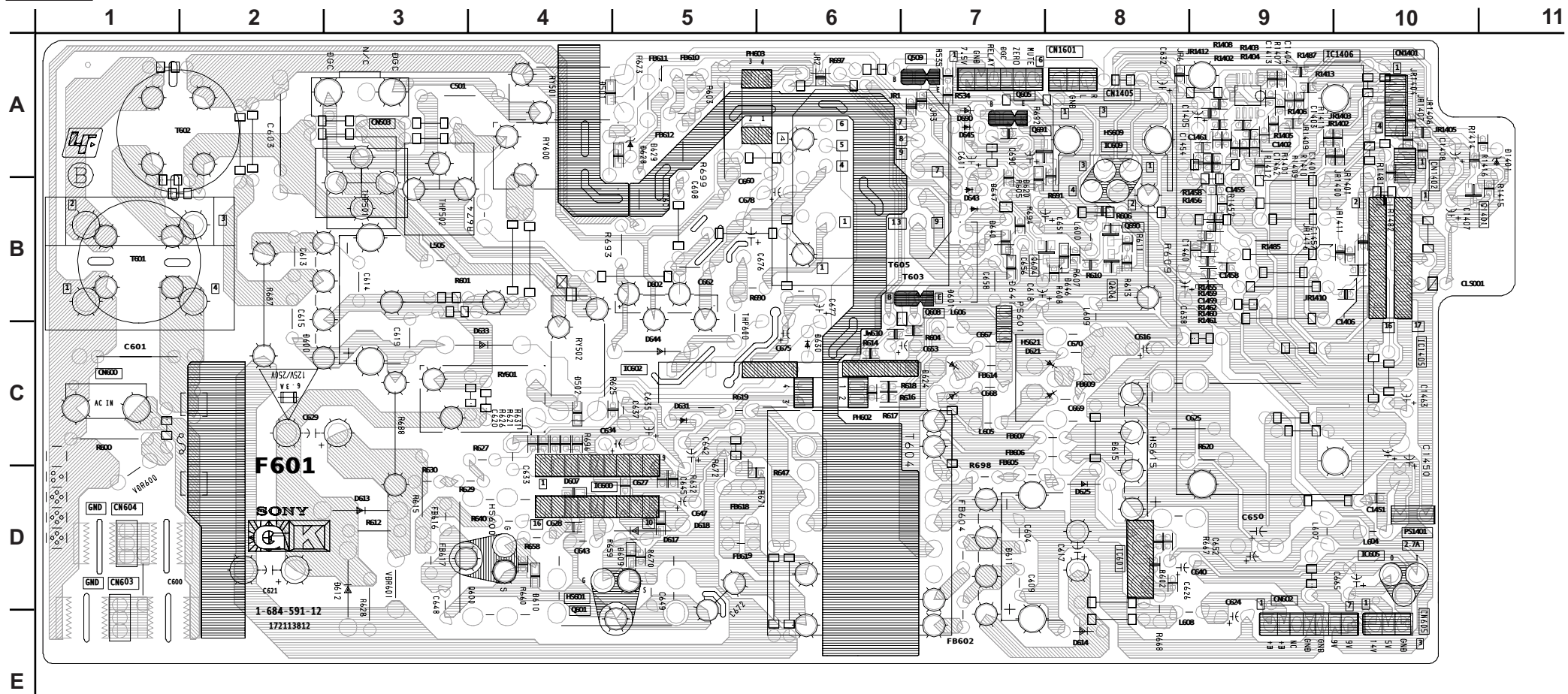

GK BOARD LOCATOR LIST

DIODE		IC	
D1401	A-11	IC1405	C-10
D501	A-5	IC1406	A-10
D600	C-2	IC600	D-5
D601	C-7	IC601	D-8
D611	D-7	IC602	C-5
D612	D-3	IC605	D-10
D613	D-3	IC609	A-8
D614	E-8	TRANSISTOR	
D615	C-8	Q1401	B-11
D618	D-5	Q509	A-7
D620	B-7	Q600	D-4
D621	C-8	Q601	E-4
D624	C-7	Q605	A-7
D625	D-8	Q606	B-8
D628	A-5	Q608	C-7
D629	A-5	Q690	B-8
D631	C-5	Q691	A-8
D640	B-7		
D641	C-7		
D645	A-7		
D646	C-8		
D647	B-7		
D690	A-7		

GK BOARD MARK(*) LIST

REF. NO.	LOCATION	KV-27FV300 KV-29FV300(N) KV-32FV300	KV-29FV300(S)	KV-36FV300
C600	A-1	#	0.0047UF 250V	#
CN604	A-1	1P	#	1P
D612	B-6	8-719-068-00	#	8-719-068-00
D613	B-6	8-719-068-00	#	8-719-068-00
F601	B-2	6.3A/125V	6.3A/250V	6.3A/125V
IC602	G-4	#	#	1-761-541-11
JW608	D-5	7.5MM	#	7.5MM
JW609	D-5	7.5MM	#	7.5MM
R603	B-3	4.7M 1/2W	#	4.7M 1/2W
R612	B-6	#	470K 1/2W	#
R628	B-6	#	470K 1/2W	#
R699	B-3	#	8.2M 1W	#
T603	A-9	1-437-783-11	1-437-784-11	1-437-783-11
T605	F-7	#	#	1-437-785-11
THP501	C-1	1-804-313-11	1-803-540-11	1-803-629-11
VDR600	A-2	1-803-585-11	1-803-967-11	1-803-585-11

#: Not Mounted

GK BOARD IC VOLTAGE LIST

IC600		IC602		IC605		9	11.0
PIN	VOLT	PIN	VOLT	PIN	VOLT		
1	-154.0	1	N/C	I	6.1	10	4.0
2	-155.0	2	N/C	O	5.0	11	3.9
3	-154.8	3	18.5	G	GND	12	GND
4	-154.4	4	N/C	IC609		13	0.4
5	-157.1	5	N/C	PIN	VOLT	14	9.9
6	-156.9	6	N/C	I	10.5	15	14.0
7	-150.2	7	9.0	O	9.0	16	GND
8	-138.8	8	0.0	G	GND	17	9.9
9	-157.1	9	0.6	IC1406			
10	-146.9	10	0.6	PIN	VOLT		
11	-157.1	11	GND	1	10.1		
12	-152.3	IC601		2	GND		
13	N/C	PIN	VOLT	3	14.0		
14	7.0	1	134.6	4	10.1		
15	-2.6	2	N/C	5	2.9		
16	1.9	3	2.4	6	N/C		
17	N/C	4	8.4	7	4.0		
18	156.8	5	GND	8	4.0		

All voltages are in V.

GK BOARD TRANSISTOR TABLE

	B	C	E
Q509	0.3	10.5	GND
Q605	7.6	18.8	7.6
Q606	0.0	0.5	GND
Q608	0.6	0.0	GND
Q690	6.1	0.5	5.9
Q691	6.9	7.6	7.6
Q1401	0.0	GND	0.6

	D	G	S
Q600	156.9	2.5	-2.5
Q601	-2.6	-152.8	-157.4

All voltages are in V.

5-4. SEMICONDUCTORS

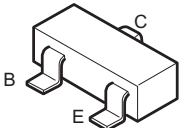
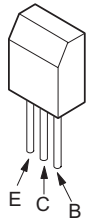
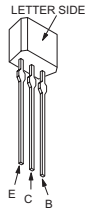
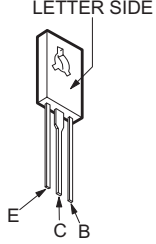
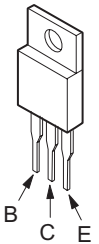
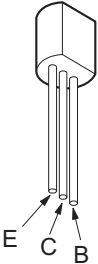
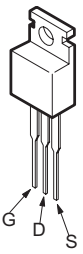
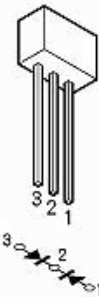
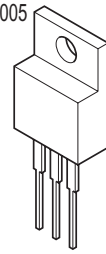
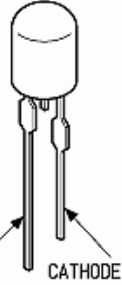
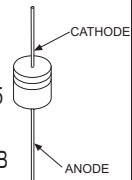
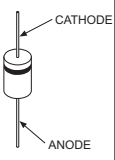
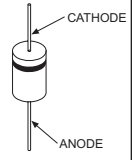
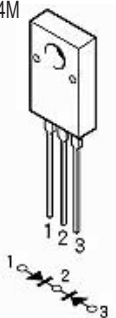
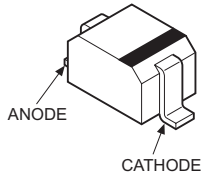
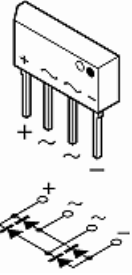
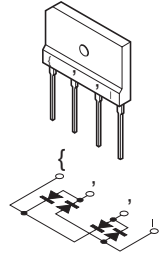
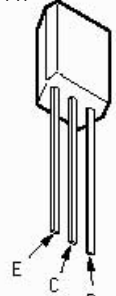
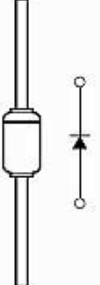
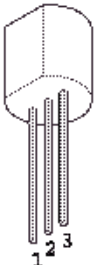
<p>2SB709A-QRS-TX 2SD601A-QRS-TX 2SC2412K-T-146-QR</p> 	<p>2SC3209LK-TP 2SD774-T-34</p> 	<p>2SD1858-Q-TV2 2SC3311A-QRSTA 2SD2144S-TP-UVV</p> 	<p>2SC3840K</p> 	<p>2SC4159-E</p> 
<p>2SA10910-TPE2</p> 	<p>IRF614</p> 	<p>SVC203SPA-AL</p> 	<p>IRFIB7N50A-LF31 2SC5511 2SA2005</p> 	<p>DAL5815</p> 
<p>D1NS4-TA2 D1NS4-TR ERA38-06TP1 ERA82-004TP5 1SS133T-77 MTZJ-T-77-3.3B MTZJ-T-77-3.6B MTZJ-T-77-3.9B MTZJ-T-77-6.2B MTZJ-T-77-6.8B MTZJ-T-77-12C MTZJ-T-77-15B MTZJ-T-77-22</p> 	<p>ERC06-15S MTZJ-T-77-5.1C MTZJ-T-77-5.6C MTZJ-T-77-7.5A MTZJ-T-77-9.1B MTZJ-T-77-10B MTZJ-T-77-30D RGP10-GPKG3 RGP02-17PKG23 RGP15GPKG23</p> 	<p>EL1Z-V1 ERB44-06TP1 ERC04-06SE 1SS83TD 1N4003GA 1N4937/23 GP08DPKG23 PR1004GT RGP10GPKG23 RU4AM-T3</p> 	<p>D10SC4M</p> 	<p>MA111-TX UDZSTE-1710B</p> 
	<p>S1VB20</p> 	<p>D4SB60L-F</p> 	<p>2SC2668-YTP</p> 	<p>MTZJ-T-77-27</p> 
<p>2SA933AS-QRT</p> 				

SECTION 6: EXPLODED VIEWS

Components not identified by a part number or description are not stocked because they are seldom required for routine service.

The component parts of an assembly are indicated by the reference numbers in the far right column of the parts list and within the dotted lines of the diagram.

* Items marked with an asterisk are not stocked since they are seldom required for routine service. Expect some delay when ordering these components.







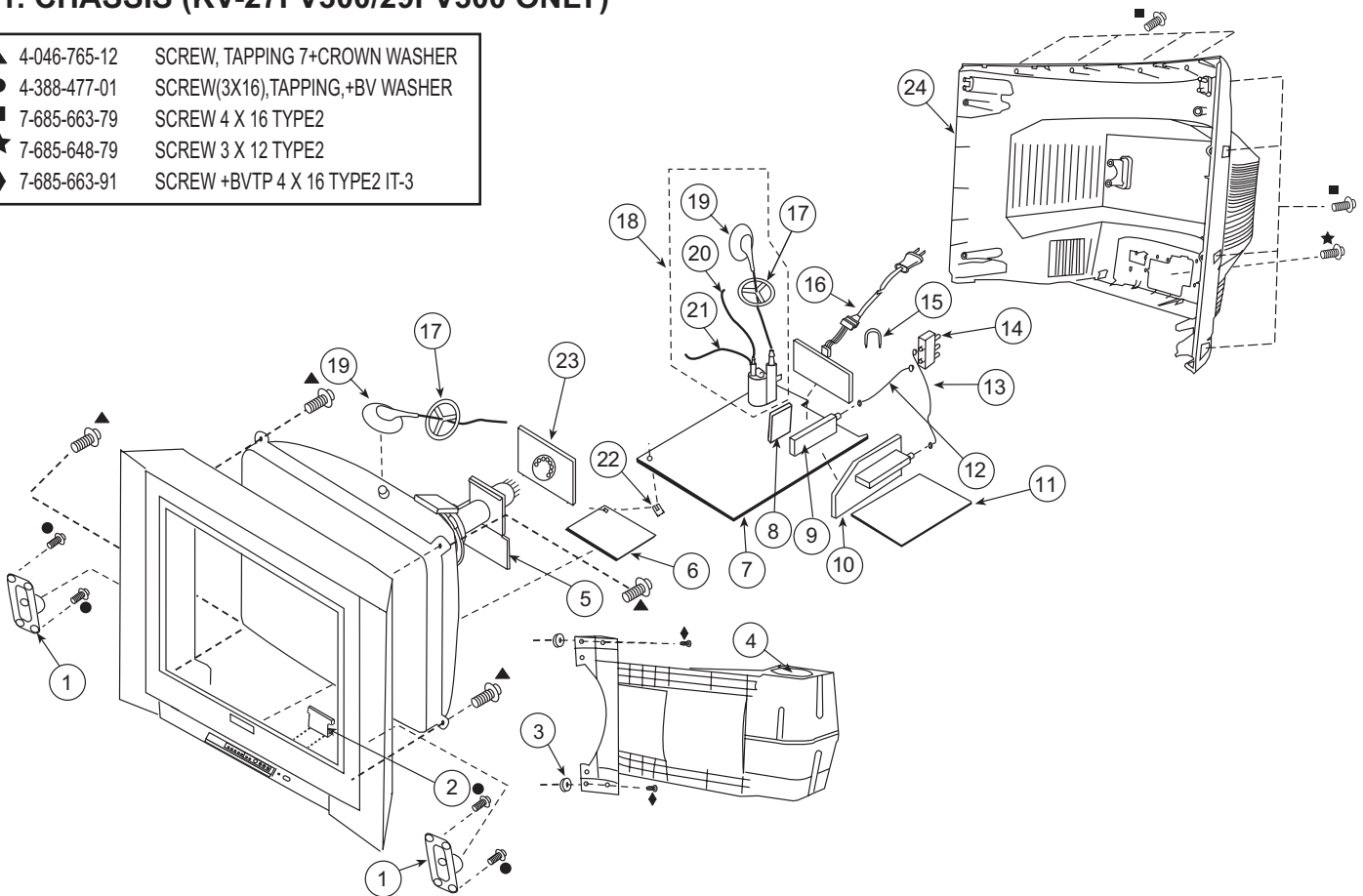

NOTE: The components identified by shading and  mark are critical for safety. Replace only with part number specified.

NOTE: Les composants identifiés par un trame et une marque  sont critiques pour la sécurité. Ne les remplacer que par une pièce portant le numéro spécifié.

6-1. CHASSIS (KV-27FV300/29FV300 ONLY)

▲	4-046-765-12	SCREW, TAPPING 7+CROWN WASHER
●	4-388-477-01	SCREW(3X16), TAPPING, +BV WASHER
■	7-685-663-79	SCREW 4 X 16 TYPE2
★	7-685-648-79	SCREW 3 X 12 TYPE2
◆	7-685-663-91	SCREW +BVTP 4 X 16 TYPE2 IT-3



REF. NO.	PART NO.	DESCRIPTION	[Assembly Includes]	REF. NO.	PART NO.	DESCRIPTION	[Assembly Includes]
	1	1-825-129-11	SPEAKER (6X12CM)	*	12	1-555-110-00	CABLE, P-P
*	2	A-1400-459-A	HR (COM) MOUNTED PC BOARD	*	13	1-558-539-21	CABLE, P-P
	3	4-374-745-31	CUSHION (A)		14	1-771-787-12	SWITCH, RF ANTENNA
	4	1-825-128-11	SPEAKER (10CM)	*	15	4-076-951-01	HINGE, PWB
*	5	A-1400-565-A	V (VAR) MOUNTED PC BOARD		16	1-791-935-12	CORD, AC POWER(WITH CONNECTOR) KV-27FV300/29FV300 (N)
*	6	A-1400-451-A	HU MOUNTED PC BOARD		16	1-769-796-31	CORD, POWER (WITH CONNECTOR) KV-29FV300 (S)
*	7	A-1300-328-A	A COMPLETE PC BOARD The high-voltage leads associated with the FBT on this board are not included and must be ordered separately (SEE 19-21).		17	4-084-918-01	HOLDER, HV CABLE
*	8	A-1400-450-A	BC MOUNTED PC BOARD		18	1-453-310-11	FBT ASSY NX-4521//X4J4 (19-21)
	9	8-598-593-00	TUNER, FSS BTF-WA421		19	1-251-374-13	CAP ASSY, HIGH-VOLTAGE
*	10	A-1400-456-A	P (VAR) MOUNTED PC BOARD		20	1-900-800-82	WIRE ASSY, FOCUS
*	11	A-1400-452-A	GK (VAR) MOUNTED PC BOARD KV-27FV300/29FV300 (N)		21	1-900-803-22	WIRE ASSY, G2 LEAD
*	11	A-1400-608-A	GK (VAR) MOUNTED PC BOARD KV-29FV300 (S)	*	22	3-696-606-02	HINGE, VI
				*	23	A-1400-455-A	C (COM) MOUNTED PC BOARD
					24	4-087-777-01	COVER, REAR

NOTE: The components identified by shading and \triangle mark are critical for safety. Replace only with part number specified.

NOTE: Les composants identifiés par un triangle et une marque \triangle sont critiques pour la sécurité. Ne les remplacer que par une pièce portant le numéro spécifié.

6-2. PICTURE TUBE (KV-27FV300/29FV300 ONLY)

- \blacktriangle 4-046-765-12 SCREW, TAPPING 7+CROWN WASHER
- \bullet 4-388-477-01 SCREW(3X16),TAPPING,+BV WASHER

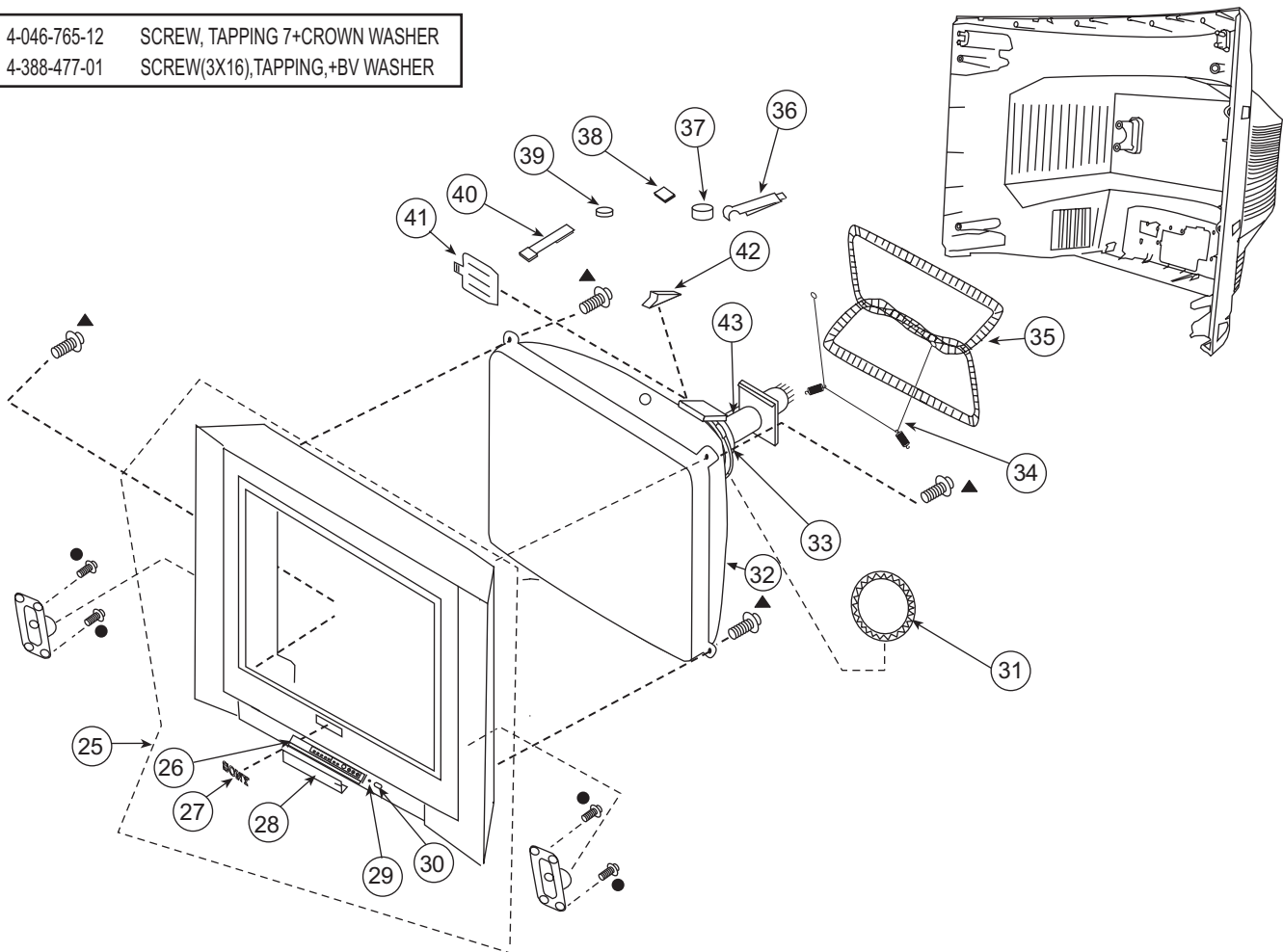

REF. NO.	PART NO.	DESCRIPTION	[Assembly Includes]	REF. NO.	PART NO.	DESCRIPTION	[(Assembly Includes)]
25	X-4040-177-1	BEZNET ASSY	(26-30)	\triangle 35	1-419-156-21	COIL, DEGAUSSING KV-27FV300/29FV300 (N)	
26	4-087-374-01	SPRING, DOOR		\triangle 35	1-419-523-21	COIL, DEGAUSSING KV-29FV300 (S)	
27	4-046-160-21	EMBLEM, SONY (NO.9)		*	36	4-062-970-12	CLIP (29RSN), DGC
\bullet 28	4-087-375-11	DOOR, CONTROL		37	1-452-094-00	CIRCULAR DISC MAGNET B	
29	4-087-156-01	GUIDE, LIGHT		38	1-452-885-11	MAGNET, LANDING	
30	4-087-150-01	BUTTON, POWER		39	1-452-032-00	MAGNET, DISC	
\triangle 31	1-452-896-11	COIL, NA ROTATION (RT200)		40	4-083-414-01	PIECE A(110), CONV CORRECT	
\triangle 32	8-735-082-05	CRT 29RSN(SDP) KV-27FV300/29FV300 (N)		41	4-081-170-01	PLATE, TLH CORRECTION	
\triangle 32	8-735-083-05	CRT 29RSN(SDP)(SOUTH) KV-29FV300 (S)		42	4-053-005-01	SPACER, DY	
\triangle 33	8-451-494-41	DY Y29RSA-V		\triangle 43	8-453-011-11	NECK ASSEMBLY NA299-M	
34	4-036-329-01	SPRING (B), TENSION					

NOTE: The components identified by shading and  mark are critical for safety. Replace only with part number specified.

NOTE: Les composants identifiés par un trame et une marque  sont critiques pour la sécurité. Ne les remplacer que par une pièce portant le numéro spécifié.

6-3. CHASSIS (KV-32FV300 ONLY)

▲	4-046-765-12	SCREW, TAPPING 7+CROWN WASHER
●	4-388-477-01	SCREW(3X16),TAPPING,+BV WASHER
■	7-685-663-79	SCREW 4 X 16 TYPE2
★	7-685-648-79	SCREW 3 X 12 TYPE2
◆	7-685-663-91	SCREW +BVTP 4 X 16 TYPE2 IT-3

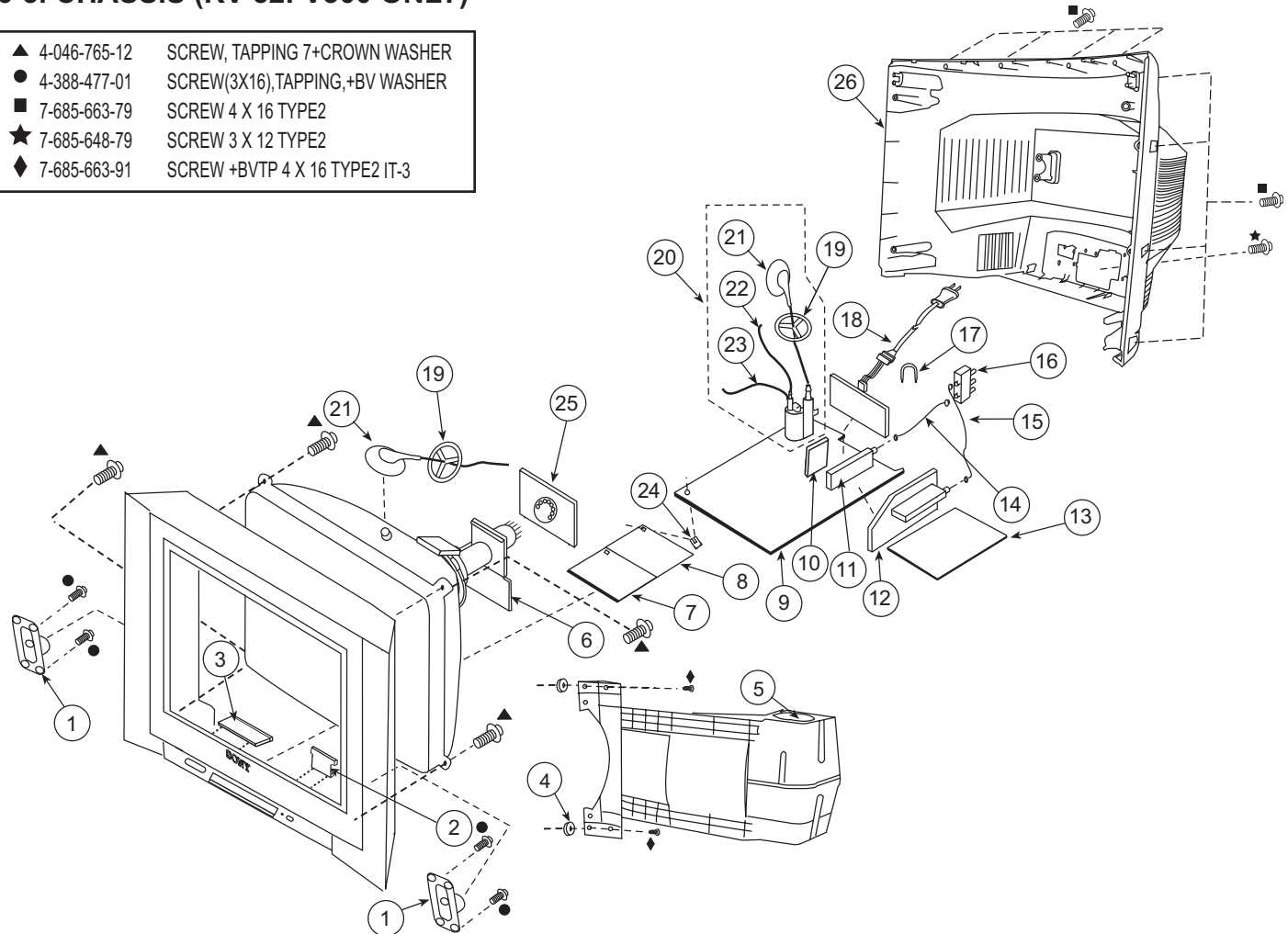

REF. NO.	PART NO.	DESCRIPTION	[Assembly Includes]	REF. NO.	PART NO.	DESCRIPTION	[(Assembly Includes)]
1	1-825-129-11	SPEAKER (6X12CM)		* 13	A-1400-452-A	GK (VAR) MOUNTED PC BOARD	
* 2	A-1400-459-A	HR (COM) MOUNTED PC BOARD		* 14	1-555-110-00	CABLE, P-P	
* 3	A-1400-460-A	T MOUNTED PC BOARD		* 15	1-558-539-21	CABLE, P-P	
4	4-374-745-31	CUSHION (A)		▲ 16	1-771-787-12	SWITCH, RF ANTENNA	
5	1-825-128-11	SPEAKER (10CM)		* 17	4-076-951-01	HINGE, PWB	
* 6	A-1400-461-A	V (VAR) MOUNTED PC BOARD		▲ 18	1-791-935-12	CORD, AC POWER(WITH CONNECTOR)	
* 7	A-1400-451-A	HU MOUNTED PC BOARD		19	4-084-918-01	HOLDER, HV CABLE	
* 8	A-1400-607-A	HD MOUNTED PC BOARD		▲ 20	1-453-338-31	FBT ASSY NX-4600//X4C4	(21-23)
* 9	A-1300-278-A	A COMPLETE PC BOARD		▲ 21	1-251-715-22	CAP ASSY, HIGH-VOLTAGE	
		The high-voltage leads associated with the FBT on this board are not included and must be ordered separately (SEE 21-23).		▲ 22	1-900-805-19	WIRE ASSY, FOCUS HV	
* 10	A-1400-450-A	BC MOUNTED PC BOARD		▲ 23	1-900-805-22	CONNECTOR ASSY, G2 HV	
● 11	8-598-593-00	TUNER, FSS BTF-WA421		* 24	3-696-606-02	HINGE, VI	
* 12	A-1400-456-A	P (VAR) MOUNTED PC BOARD		* 25	A-1400-455-A	C (COM) MOUNTED PC BOARD	
				26	4-087-878-01	COVER, REAR	





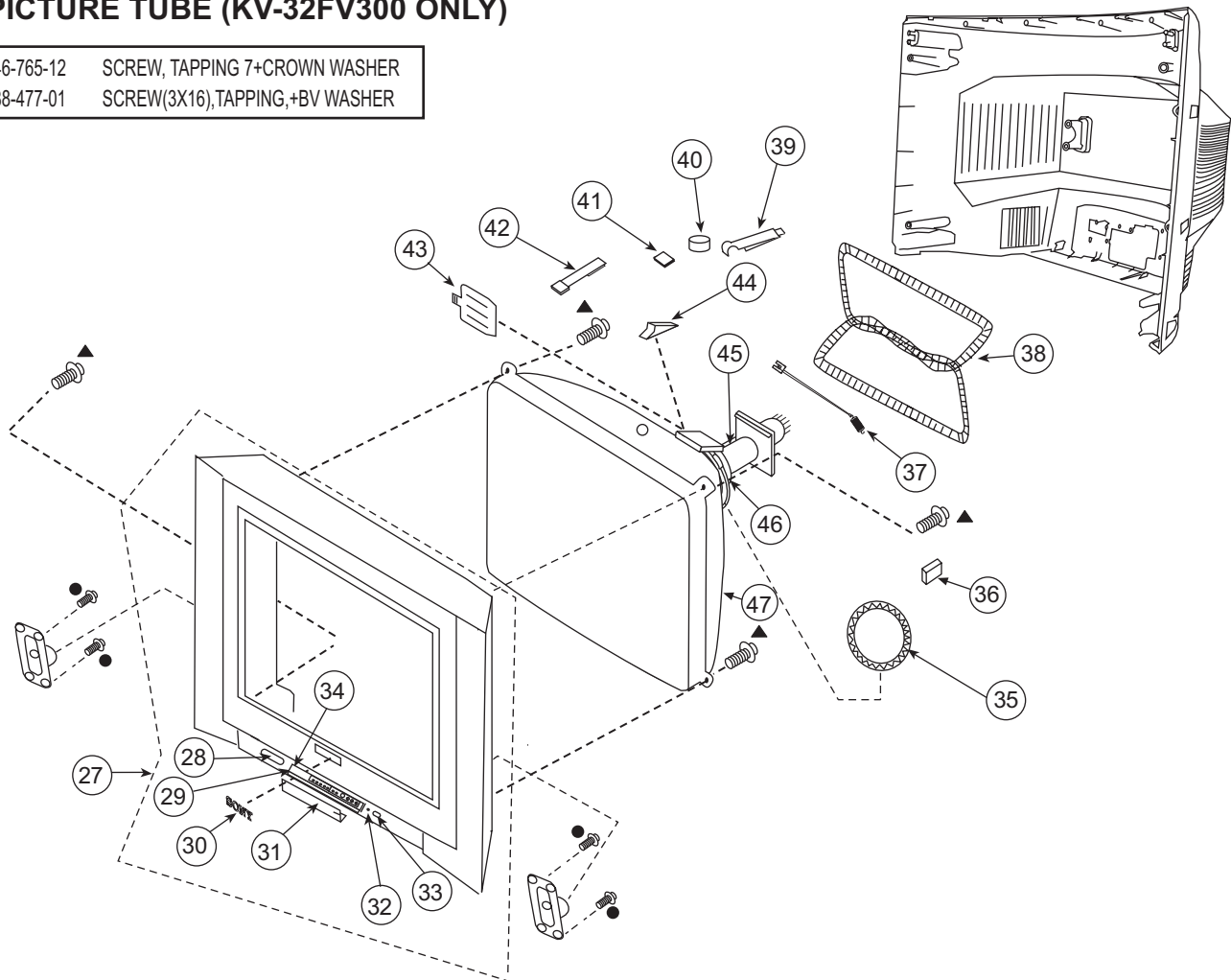

NOTE: The components identified by shading and  mark are critical for safety. Replace only with part number specified.

NOTE: Les composants identifiés par un trame et une marque  sont critiques pour la sécurité. Ne les remplacer que par une pièce portant le numéro spécifié.

6-4. PICTURE TUBE (KV-32FV300 ONLY)

- ▲ 4-046-765-12 SCREW, TAPPING 7+CROWN WASHER
- 4-388-477-01 SCREW(3X16),TAPPING,+BV WASHER



REF. NO.	PART NO.	DESCRIPTION	[Assembly Includes]	REF. NO.	PART NO.	DESCRIPTION	[(Assembly Includes)]
27	X-4040-115-1	BEZNET ASSY	(28-34)		38	1-428-988-11	DEGAUSSING COIL (32" 120V)
28	4-086-887-01	PANEL, IR		39	4-065-895-11	HOLDER, DGC	
29	4-087-374-01	SPRING, DOOR		40	1-452-032-00	MAGNET,DISC	
30	4-046-160-21	EMBLEM, SONY (NO.9)		41	1-452-885-11	MAGNET, LANDING	
 31	4-087-375-11	DOOR, CONTROL		42	4-083-414-01	PIECE A(110), CONV CORRECT	
32	4-087-156-01	GUIDE, LIGHT		43	4-081-170-01	PLATE, TLH CORRECTION	
33	4-087-150-01	BUTTON, POWER		44	4-053-005-01	SPACER, DY	
34	4-036-880-11	DAMPER			45	8-453-007-41	NECK ASSEMBLY NA324-M4
 35	1-452-896-11	COIL, NA ROTATION (RT200)			46	8-451-499-41	DY Y34RSA-V
* 36	4-078-952-01	CUSHION, 20MM X 20MM			47	8-735-066-05	CRT 34RSN(SDP)
37	4-082-641-01	SPRING 45MM					

NOTE: The components identified by shading and  mark are critical for safety. Replace only with part number specified.

NOTE: Les composants identifiés par un trame et une marque  sont critiques pour la sécurité. Ne les remplacer que par une pièce portant le numéro spécifié.

6-5. CHASSIS (KV-36FV300 ONLY)

▲	4-046-765-12	SCREW, TAPPING 7+CROWN WASHER
●	4-388-477-01	SCREW(3X16), TAPPING, +BV WASHER
■	7-685-663-79	SCREW 4 X 16 TYPE2
★	7-685-648-79	SCREW 3 X 12 TYPE2
◆	7-685-663-91	SCREW +BVTP 4 X 16 TYPE2 IT-3

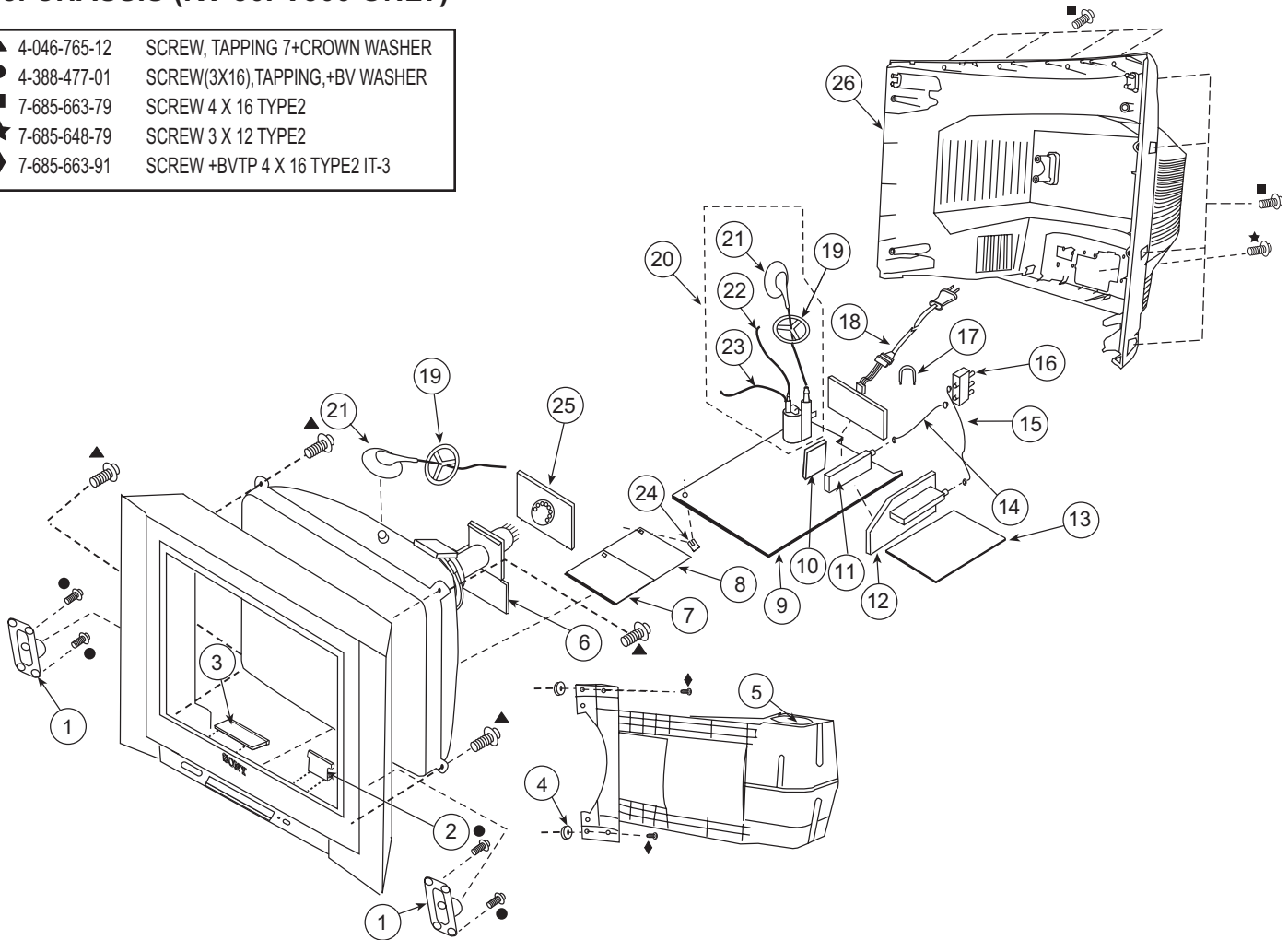

REF. NO.	PART NO.	DESCRIPTION	[Assembly Includes]	REF. NO.	PART NO.	DESCRIPTION	[(Assembly Includes)]
1	1-825-129-11	SPEAKER (6X12CM)		* 13	A-1400-583-A	GK (VAR) MOUNTED PC BOARD	
* 2	A-1400-459-A	HR (COM) MOUNTED PC BOARD		* 14	1-555-110-00	CABLE, P-P	
* 3	A-1400-460-A	T MOUNTED PC BOARD		* 15	1-558-539-21	CABLE, P-P	
4	4-374-745-31	CUSHION (A)		▲ 16	1-771-787-12	SWITCH, RF ANTENNA	
5	1-825-128-11	SPEAKER (10CM)		* 17	4-076-951-01	HINGE, PWB	
* 6	A-1400-581-A	V (VAR) MOUNTED PC BOARD		▲ 18	1-791-935-12	CORD, AC POWER(WITH CONNECTOR)	
* 7	A-1400-451-A	HU MOUNTED PC BOARD		19	3-704-372-71	HOLDER, HV CABLE	
* 8	A-1400-607-A	HD MOUNTED PC BOARD		▲ 20	1-453-338-21	FBT ASSY NX-4600//X4C4	(21-23)
* 9	A-1300-336-A	A COMPLETE PC BOARD		▲ 21	1-251-715-32	CAP ASSY, HIGH-VOLTAGE	
		The high-voltage leads associated with the FBT on this board are not included and must be ordered separately (SEE 21-23).		▲ 22	1-900-805-19	WIRE ASSY, FOCUS HV	
* 10	A-1400-450-A	BC MOUNTED PC BOARD		▲ 23	1-900-805-22	CONNECTOR ASSY, G2 HV	
▶ 11	8-598-593-00	TUNER, FSS BTF-WA421		* 24	3-696-606-02	HINGE, VI	
* 12	A-1400-456-A	P (VAR) MOUNTED PC BOARD		* 25	A-1400-580-A	C (VAR) MOUNTED PC BOARD	
				26	4-086-697-01	COVER, REAR	

NOTE: The components identified by shading and \triangle mark are critical for safety. Replace only with part number specified.

NOTE: Les composants identifiés par un triangle et une marque \triangle sont critiques pour la sécurité. Ne les remplacer que par une pièce portant le numéro spécifié.

6-6. PICTURE TUBE (KV-36FV300 ONLY)

- \blacktriangle 4-046-765-12 SCREW, TAPPING 7+CROWN WASHER
- \bullet 4-388-477-01 SCREW(3X16),TAPPING,+BV WASHER

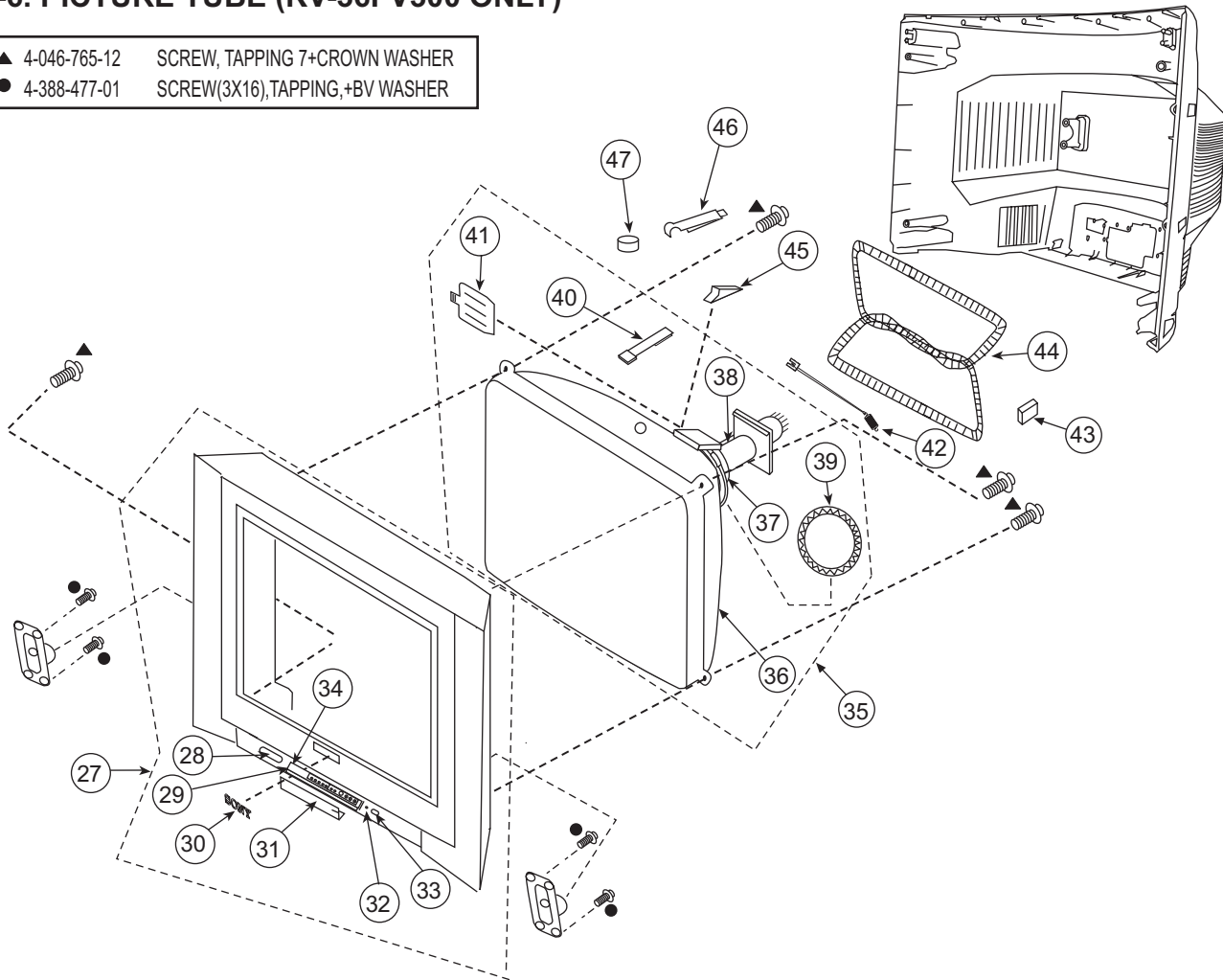

REF. NO.	PART NO.	DESCRIPTION	[Assembly Includes]	REF. NO.	PART NO.	DESCRIPTION	[(Assembly Includes)]
27	X-4039-673-1	BEZNET ASSY	(27-34)	\triangle 37	1-451-531-11	DY	
28	4-086-887-01	PANEL, IR		\triangle 37	8-451-506-11	KV-36FV300 (U) (CND) DY Y38RSA-X	
29	4-087-374-01	SPRING, DOOR		\triangle 38	8-453-007-41	KV-36FV300 (HAWAII) NECK ASSEMBLY, NA324-M4	
30	4-046-160-21	EMBLEM, SONY (NO.9)		\triangle 39	1-452-896-11	COIL, NA ROTATION (RT200)	
\bullet 31	4-087-375-11	DOOR, CONTROL		40	4-062-047-02	PIECE A(110), CONV CORRECT	
32	4-087-156-01	GUIDE, LIGHT		41	4-081-170-01	PLATE, TLH CORRECTION	
33	4-087-150-01	BUTTON, POWER		42	4-082-641-01	SPRING, 45MM	
34	4-036-880-11	DAMPER		*	4-078-952-01	CUSHION, 20MM X 20MM	
\triangle 35	8-735-048-61	ITC 38RSN-A1	(36-41)	\triangle 44	1-428-987-11	DEGAUSSING COIL (36" 120V)	
\triangle 35	8-735-081-61	ITC 38RSN-A1M	(36-41)	45	4-053-005-01	SPACER, DY	
\triangle 36	8-735-045-05	CRT 38RSN/F73504801		46	4-065-895-11	HOLDER, DGC	
\triangle 36	8-735-081-05	CRT 38RSN		47	1-452-032-11	MAGNET,DISC	
		KV-36FV300 (U) (CND)					
		KV-36FV300 (HAWAII)					

SECTION 7: ELECTRICAL PARTS LIST

NOTE: The components identified by shading and  mark are critical for safety. Replace only with part number specified.

NOTE: Les composants identifiés par un trame et une marque  sont critiques pour la sécurité. Ne les remplacer que par une pièce portant le numéro spécifique.

The components in this manual identified by the following symbol:  indicate parts that have been carefully factory-selected to satisfy regulations regarding X-ray radiation For each set.

Should replacement be required for one of these components, replace only with the value originally used.







* Items marked with an asterisk are not stocked since they are seldom required for routine service. Expect some delay when ordering these components.

RESISTORS

- All resistors are in ohms
- F : nonflammable
- All variable and adjustable resistors have characteristic curve B, unless otherwise noted.





When ordering parts by reference number, please include the board name.

REF. NO.	PART NO.	DESCRIPTION	VALUES	REF. NO.	PART NO.	DESCRIPTION	VALUES
	* A-1300-278-A	A BOARD, COMPLETE (KV-32FV300 ONLY)		C006	1-162-964-11	CERAMIC CHIP	0.001µF 10% 50V
	* A-1300-328-A	A BOARD, COMPLETE (KV-27FV300/29FV300 ONLY)		C007	1-164-230-11	CERAMIC CHIP	220pF 5% 50V
	* A-1300-336-A	A BOARD, COMPLETE (KV-36FV300 ONLY)		C008	1-126-960-11	ELECT	1µF 20% 50V
				C009	1-162-964-11	CERAMIC CHIP	0.001µF 10% 50V
				C014	1-162-919-11	CERAMIC CHIP	22pF 5% 50V
				C015	1-162-919-11	CERAMIC CHIP	22pF 5% 50V
				C016	1-126-941-11	ELECT	470µF 20% 25V
				C017	1-162-966-11	CERAMIC CHIP	0.0022µF 10% 50V
				C018	1-164-230-11	CERAMIC CHIP	220pF 5% 50V
				C020	1-164-230-11	CERAMIC CHIP	220pF 5% 50V
	4-382-854-11	SCREW (M3X10), P, SW (+)		C026	1-164-230-11	CERAMIC CHIP	220pF 5% 50V
<p>The high-voltage leads associated with the FBT on the A board are not included and must be ordered separately. Order the following leads when requesting this A board:</p>				C027	1-162-964-11	CERAMIC CHIP	0.001µF 10% 50V
	1-251-374-13	HV CAP ASSY		C028	1-162-964-11	CERAMIC CHIP	0.001µF 10% 50V
	1-900-800-82	FOCUS LEAD		C029	1-126-960-11	ELECT	1µF 20% 50V
	1-900-803-22	G2 LEAD (KV-27FV300/29FV300 ONLY)		C030	1-165-176-11	CERAMIC CHIP	0.047µF 10% 16V
	1-251-715-22	HV CAP ASSY		C031	1-164-230-11	CERAMIC CHIP	220pF 5% 50V
	1-900-805-19	FOCUS LEAD		C032	1-126-964-11	ELECT	10µF 20% 50V
	1-900-805-22	G2 LEAD (KV-32FV300 ONLY)		C033	1-125-837-91	CERAMIC CHIP	1µF 10% 6.3V
				C034	1-162-964-11	CERAMIC CHIP	0.001µF 10% 50V
				C035	1-162-964-11	CERAMIC CHIP	0.001µF 10% 50V
				C036	1-162-964-11	CERAMIC CHIP	0.001µF 10% 50V
				C037	1-164-230-11	CERAMIC CHIP	220pF 5% 50V
				C038	1-164-230-11	CERAMIC CHIP	220pF 5% 50V
				C039	1-162-964-11	CERAMIC CHIP	0.001µF 10% 50V
				C041	1-164-230-11	CERAMIC CHIP	220pF 5% 50V
				C043	1-164-230-11	CERAMIC CHIP	220pF 5% 50V
				C044	1-164-230-11	CERAMIC CHIP	220pF 5% 50V
				C045	1-126-964-11	ELECT	10µF 20% 50V
				C046	1-126-964-11	ELECT	10µF 20% 50V
				C047	1-126-941-11	ELECT	470µF 20% 25V
				C048	1-115-416-11	CERAMIC CHIP	0.001µF 5% 25V
				C049	1-126-964-11	ELECT	10µF 20% 50V
				C050	1-126-941-11	ELECT	470µF 20% 25V
				C051	1-126-947-11	ELECT	47µF 20% 25V
				C052	1-162-968-11	CERAMIC CHIP	0.0047µF 10% 50V
CAPACITOR							
C001	1-164-315-11	CERAMIC CHIP	470pF 5% 50V				
C002	1-164-230-11	CERAMIC CHIP	220pF 5% 50V				
C003	1-107-826-11	CERAMIC CHIP	0.1µF 10% 16V				
C004	1-126-947-11	ELECT	47µF 20% 25V				
C005	1-164-739-11	CERAMIC CHIP	560pF 5% 50V				





















REF. NO.	PART NO.	DESCRIPTION	VALUES	REF. NO.	PART NO.	DESCRIPTION	VALUES
C054	1-126-963-11	ELECT	4.7μF 20% 50V	C340	1-126-767-11	ELECT	1000μF 20% 16V
C055	1-126-933-11	ELECT	100μF 20% 16V	C341	1-126-947-11	ELECT	47μF 20% 25V
C060	1-164-230-11	CERAMIC CHIP	220pF 5% 50V	C343	1-107-826-11	CERAMIC CHIP	0.1μF 10% 16V
C062	1-125-837-91	CERAMIC CHIP	1μF 10% 6.3V	C344	1-162-970-11	CERAMIC CHIP	0.01μF 10% 25V
C065	1-125-891-11	CERAMIC CHIP	0.47μF 10% 10V	C345	1-113-619-11	CERAMIC CHIP	0.47μF 10V
C101	1-115-416-11	CERAMIC CHIP	0.001μF 5% 25V	C346	1-162-970-11	CERAMIC CHIP	0.01μF 10% 25V
C102	1-115-416-11	CERAMIC CHIP	0.001μF 5% 25V	C347	1-162-970-11	CERAMIC CHIP	0.01μF 10% 25V
C111	1-164-230-11	CERAMIC CHIP	220pF 5% 50V	C351	1-162-970-11	CERAMIC CHIP	0.01μF 10% 25V
C120	1-162-915-11	CERAMIC CHIP	10pF 0.50pF 50V	C352	1-126-947-11	ELECT	47μF 20% 25V
C121	1-162-915-11	CERAMIC CHIP	10pF 0.50pF 50V	C353	1-107-826-11	CERAMIC CHIP	0.1μF 10% 16V
C122	1-107-826-11	CERAMIC CHIP	0.1μF 10% 16V	C354	1-162-970-11	CERAMIC CHIP	0.01μF 10% 25V
C133	1-164-230-11	CERAMIC CHIP	220pF 5% 50V	C355	1-162-970-11	CERAMIC CHIP	0.01μF 10% 25V
C200	1-107-826-11	CERAMIC CHIP	0.1μF 10% 16V	C356	1-162-970-11	CERAMIC CHIP	0.01μF 10% 25V
C201	1-107-826-11	CERAMIC CHIP	0.1μF 10% 16V	C357	1-126-960-11	ELECT	1μF 20% 50V
C202	1-107-826-11	CERAMIC CHIP	0.1μF 10% 16V	C358	1-162-970-11	CERAMIC CHIP	0.01μF 10% 25V
C203	1-107-826-11	CERAMIC CHIP	0.1μF 10% 16V	C359	1-162-961-11	CERAMIC CHIP	330pF 10% 50V
C206	1-107-826-11	CERAMIC CHIP	0.1μF 10% 16V	C360	1-126-960-11	ELECT	1μF 20% 50V
C207	1-107-826-11	CERAMIC CHIP	0.1μF 10% 16V	C364	1-162-923-11	CERAMIC CHIP	47pF 5% 50V
C208	1-107-826-11	CERAMIC CHIP	0.1μF 10% 16V	C365	1-162-117-00	CERAMIC	100pF 10% 500V
C209	1-107-826-11	CERAMIC CHIP	0.1μF 10% 16V	C366	1-113-619-11	CERAMIC CHIP	0.47μF 10V
C210	1-126-963-11	ELECT	4.7μF 20% 50V	C367	1-113-619-11	CERAMIC CHIP	0.47μF 10V
C211	1-126-963-11	ELECT	4.7μF 20% 50V	C368	1-113-619-11	CERAMIC CHIP	0.47μF 10V
C212	1-126-963-11	ELECT	4.7μF 20% 50V	C371	1-115-156-11	CERAMIC CHIP	1μF 10V
C213	1-126-963-11	ELECT	4.7μF 20% 50V	C372	1-162-970-11	CERAMIC CHIP	0.01μF 10% 25V
C300	1-126-959-11	ELECT	0.47μF 20% 50V	C393	1-107-826-11	CERAMIC CHIP	0.1μF 10% 16V
C302	1-126-963-11	ELECT	4.7μF 20% 50V	C397	1-126-933-11	ELECT	100μF 20% 16V
C303	1-107-826-11	CERAMIC CHIP	0.1μF 10% 16V	C400	1-128-934-91	CERAMIC CHIP	0.33μF 20% 10V
C305	1-107-826-11	CERAMIC CHIP	0.1μF 10% 16V	C401	1-164-227-11	CERAMIC CHIP	0.022μF 10% 25V
C309	1-107-826-11	CERAMIC CHIP	0.1μF 10% 16V	C402	1-164-174-11	CERAMIC CHIP	0.0082μF 10% 25V
C311	1-126-947-11	ELECT	47μF 20% 25V	C403	1-162-967-11	CERAMIC CHIP	0.0033μF 10% 50V
C313	1-107-826-11	CERAMIC CHIP	0.1μF 10% 16V	C404	1-162-967-11	CERAMIC CHIP	0.0033μF 10% 50V
C319	1-107-826-11	CERAMIC CHIP	0.1μF 10% 16V	C405	1-164-677-11	CERAMIC CHIP	0.033μF 10% 16V
C320	1-126-959-11	ELECT	0.47μF 20% 50V	C406	1-164-677-11	CERAMIC CHIP	0.033μF 10% 16V
C321	1-126-947-11	ELECT	47μF 20% 25V	C407	1-162-965-11	CERAMIC CHIP	0.0015μF 10% 50V
C322	1-107-826-11	CERAMIC CHIP	0.1μF 10% 16V	C408	1-162-965-11	CERAMIC CHIP	0.0015μF 10% 50V
C325	1-162-923-11	CERAMIC CHIP	47pF 5% 50V	C409	1-127-715-91	CERAMIC CHIP	0.22μF 10% 16V
C326	1-164-373-11	CERAMIC CHIP	0.033μF 25V	C410	1-127-715-91	CERAMIC CHIP	0.22μF 10% 16V
C327	1-107-826-11	CERAMIC CHIP	0.1μF 10% 16V	C411	1-128-934-91	CERAMIC CHIP	0.33μF 20% 10V
C330	1-126-964-11	ELECT	10μF 20% 50V	C412	1-126-961-11	ELECT	2.2μF 20% 50V
C333	1-126-963-11	ELECT	4.7μF 20% 50V	C413	1-126-960-11	ELECT	1μF 20% 50V
C335	1-162-918-11	CERAMIC CHIP	18pF 5% 50V	C414	1-126-960-11	ELECT	1μF 20% 50V
C337	1-164-315-11	CERAMIC CHIP	470pF 5% 50V	C415	1-126-960-11	ELECT	1μF 20% 50V
C338	1-107-826-11	CERAMIC CHIP	0.1μF 10% 16V	C416	1-126-960-11	ELECT	1μF 20% 50V
C339	1-113-619-11	CERAMIC CHIP	0.47μF 10V	C417	1-115-416-11	CERAMIC CHIP	0.001μF 5% 25V

NOTE: The components identified by shading and  mark are critical for safety. Replace only with part number specified.

NOTE: Les composants identifiés par un trame et une  sont critiques pour la sécurité. Ne les remplacer que par une pièce portant le numéro spécifique.







REF. NO.	PART NO.	DESCRIPTION	VALUES	REF. NO.	PART NO.	DESCRIPTION	VALUES
C418	1-126-963-11	ELECT	4.7μF 20% 50V	C515	1-104-987-11	MYLAR	0.001μF 10% 100V
C420	1-126-960-11	ELECT	1μF 20% 50V	 C516	1-115-521-11	FILM	0.82μF 5% 250V
C422	1-126-935-11	ELECT	470μF 20% 16V		(KV-32FV300/36FV300 ONLY)		
C426	1-126-964-11	ELECT	10μF 20% 50V	 C516	1-115-522-11	FILM	1μF 5% 250V
C427	1-126-964-11	ELECT	10μF 20% 50V		(KV-27FV300/29FV300 ONLY)		
C428	1-162-970-11	CERAMIC CHIP	0.01μF 10% 25V	C517	1-107-649-11	ELECT	2.2μF 20% 250V
C429	1-127-715-91	CERAMIC CHIP	0.22μF 10% 16V	C518	1-106-387-00	MYLAR	0.068μF 10% 200V
C430	1-162-968-11	CERAMIC CHIP	0.0047μF 10% 50V	C519	1-107-612-11	CERAMIC	100pF 5% 500V
C431	1-127-715-91	CERAMIC CHIP	0.22μF 10% 16V	C520	1-164-646-11	CERAMIC	2200pF 10% 500V
C432	1-104-665-11	ELECT	100μF 20% 25V	C521	1-162-964-11	CERAMIC CHIP	0.001μF 10% 50V
C433	1-162-970-11	CERAMIC CHIP	0.01μF 10% 25V	C522	1-126-960-11	ELECT	1μF 20% 50V
C434	1-162-968-11	CERAMIC CHIP	0.0047μF 10% 50V	C525	1-102-244-00	CERAMIC	220pF 10% 500V
C435	1-162-968-11	CERAMIC CHIP	0.0047μF 10% 50V	C526	1-107-662-11	ELECT	22μF 20% 250V
C442	1-127-715-91	CERAMIC CHIP	0.22μF 10% 16V	 C527	1-162-116-00	CERAMIC	680pF 10% 2KV
		(KV-32FV300/36FV300 ONLY)		C528	1-162-966-11	CERAMIC CHIP	0.0022μF 10% 50V
C443	1-127-715-91	CERAMIC CHIP	0.22μF 10% 16V	C529	1-128-551-11	ELECT	22μF 20% 25V
		(KV-32FV300/36FV300 ONLY)		C530	1-130-475-00	MYLAR	0.0022μF 5% 50V
C452	1-107-826-11	CERAMIC CHIP	0.1μF 10% 16V	 C531	1-126-965-91	ELECT	22μF 20% 50V
C453	1-107-826-11	CERAMIC CHIP	0.1μF 10% 16V	 C532	1-126-965-91	ELECT	22μF 20% 50V
C501	1-102-110-00	CERAMIC	220pF 10% 50V	C534	1-126-967-11	ELECT	47μF 20% 50V
C502	1-126-959-11	ELECT	0.47μF 20% 50V	 C535	1-136-165-00	FILM	0.1μF 5% 50V
C503	1-164-315-11	CERAMIC CHIP	470pF 5% 50V	C537	1-126-941-11	ELECT	470μF 20% 25V
C504	1-102-228-00	CERAMIC	470pF 10% 500V	C539	1-126-941-11	ELECT	470μF 20% 25V
C505	1-102-228-00	CERAMIC	470pF 10% 500V	C540	1-107-995-11	ELECT	100μF 160V
C506	1-106-383-00	MYLAR	0.047μF 10% 200V	C541	1-128-560-11	ELECT	22μF 20% 100V
 C507	1-162-116-00	CERAMIC	680pF 10% 2KV	C544	1-129-718-00	FILM	0.022μF 5% 630V
C508	1-102-228-00	CERAMIC	470pF 10% 500V	C545	1-106-387-00	MYLAR	0.068μF 10% 200V
 C509	1-162-116-00	CERAMIC	680pF 10% 2KV	C546	1-104-987-11	MYLAR	0.001μF 10% 100V
C510	1-137-150-11	MYLAR	0.01μF 10% 100V		(KV-32FV300/36FV300 ONLY)		
 C511	1-117-652-11	FILM	22000pF 3% 1.2KV	C547	1-104-987-11	MYLAR	0.001μF 10% 100V
		(KV-32FV300/36FV300 ONLY)			(KV-32FV300/36FV300 ONLY)		
 C511	1-117-717-11	FILM	17000pF 3% 1.2KV	C550	1-102-002-00	CERAMIC	680pF 10% 500V
		(KV-27FV300/29FV300 ONLY)			(KV-32FV300/36FV300 ONLY)		
C512	1-129-709-91	FILM	0.0039μF 5% 630V	C550	1-164-735-11	CERAMIC	0.0015μF 10% 500V
		(KV-27FV300/29FV300 ONLY)			(KV-27FV300/29FV300 ONLY)		
C512	1-129-928-00	FILM	0.0027μF 10% 630V	C551	1-109-954-11	ELECT	0.47μF 20% 160V
		(KV-32FV300/36FV300 ONLY)		C552	1-102-244-00	CERAMIC	220pF 10% 500V
 C513	1-129-722-00	FILM	0.047μF 5% 630V	 C553	1-107-846-11	FILM	0.1μF 5% 250V
		(KV-27FV300/29FV300 ONLY)			(KV-27FV300/29FV300 ONLY)		
 C513	1-130-118-91	FILM	0.051μF 5% 400V	 C553	1-117-667-11	FILM	0.47μF 5% 250V
		(KV-32FV300/36FV300 ONLY)			(KV-32FV300/36FV300 ONLY)		
 C514	1-109-844-11	FILM	0.68μF 5% 250V	 C554	1-117-629-11	FILM	2700pF 3% 1.2KV
		(KV-27FV300/29FV300 ONLY)			(KV-27FV300/29FV300 ONLY)		
 C514	1-115-521-11	FILM	0.82μF 5% 250V				
		(KV-32FV300/36FV300 ONLY)					

NOTE: The components identified by shading and  mark are critical for safety. Replace only with part number specified.

NOTE: Les composants identifiés par un trame et une  sont critiques pour la sécurité. Ne les remplacer que par une pièce portant le numéro spécifique.











REF. NO.	PART NO.	DESCRIPTION	VALUES			REF. NO.	PART NO.	DESCRIPTION	VALUES
	C554	1-117-635-11 FILM (KV-32FV300/36FV300 ONLY)	4700pF	3%	1.2KV	D008	8-719-404-50	DIODE MA111-TX	
	C561	1-126-967-11 ELECT	47μF	20%	50V	D009	8-719-982-22	DIODE MTZJ-T-77-30D	
	C563	1-104-666-11 ELECT	220μF	20%	25V	D010	8-719-921-44	DIODE MTZJ-T-77-5.1C	
	C564	1-126-960-11 ELECT	1μF	20%	50V	D110	8-719-991-33	DIODE 1SS133T-77	
	C565	1-126-969-11 ELECT	220μF	20%	50V	D111	8-719-109-93	DIODE MTZJ-T-77-6.2B	
	C568	1-136-169-00 FILM	0.22μF	5%	50V	D112	8-719-109-93	DIODE MTZJ-T-77-6.2B	
	C571	1-126-942-61 ELECT	1000μF	20%	25V	D113	8-719-921-44	DIODE MTZJ-T-77-5.1C	
	C572	1-126-942-61 ELECT	1000μF	20%	25V	D200	8-719-929-15	DIODE MTZJ-T-77-9.1B	
	C590	1-126-964-11 ELECT	10μF	20%	50V	D201	8-719-929-15	DIODE MTZJ-T-77-9.1B	
	C1501	1-107-846-11 FILM (KV-32FV300/36FV300 ONLY)	0.1μF	5%	250V	D209	8-719-929-15	DIODE MTZJ-T-77-9.1B	
	C6001	1-126-940-11 ELECT	330μF	20%	25V	D210	8-719-929-15	DIODE MTZJ-T-77-9.1B	
	C6002	1-126-947-11 ELECT	47μF	20%	25V	D211	8-719-929-15	DIODE MTZJ-T-77-9.1B	
	C6003	1-125-837-91 CERAMIC CHIP	1μF	10%	6.3V	D212	8-719-929-15	DIODE MTZJ-T-77-9.1B	
	C6005	1-126-768-11 ELECT	2200μF	20%	16V	D213	8-719-929-15	DIODE MTZJ-T-77-9.1B	
		CONNECTOR				D217	8-719-929-15	DIODE MTZJ-T-77-9.1B	
*	CN001	1-560-124-00 PLUG,CONNECTOR (2.5MM)	4P			D218	8-719-929-15	DIODE MTZJ-T-77-9.1B	
*	CN002	1-564-507-11 PLUG,CONNECTOR	4P			D219	8-719-929-15	DIODE MTZJ-T-77-9.1B	
*	CN003	1-564-509-11 PLUG,CONNECTOR	6P			D302	8-719-981-99	DIODE MTZJ-T-77-3.3	
*	CN004	1-564-507-11 PLUG,CONNECTOR	4P			D303	8-719-929-15	DIODE MTZJ-T-77-9.1B	
*	CN005	1-564-508-11 PLUG,CONNECTOR	5P			D304	8-719-921-44	DIODE MTZJ-T-77-5.1C	
*	CN006	1-564-506-11 PLUG,CONNECTOR	3P			D305	8-719-929-15	DIODE MTZJ-T-77-9.1B	
*	CN303	1-564-511-11 PLUG,CONNECTOR	8P			D306	8-719-929-15	DIODE MTZJ-T-77-9.1B	
	CN306	1-573-298-21 CONNECTOR, BOARD TO BOARD	20P			D307	8-719-929-15	DIODE MTZJ-T-77-9.1B	
*	CN401	1-564-508-11 PLUG,CONNECTOR (KV-32FV300/36FV300 ONLY)	5P			D308	8-719-929-15	DIODE MTZJ-T-77-9.1B	
*	CN410	1-564-506-11 PLUG,CONNECTOR	3P			D309	8-719-929-15	DIODE MTZJ-T-77-9.1B	
*	CN501	1-580-798-11 CONNECTOR PIN (DY)	6P			D310	8-719-929-15	DIODE MTZJ-T-77-9.1B	
*	CN502	1-764-333-11 PLUG,CONNECTOR	10P			D311	8-719-929-15	DIODE MTZJ-T-77-9.1B	
*	CN503	1-564-510-11 PLUG,CONNECTOR	7P			D312	8-719-929-15	DIODE MTZJ-T-77-9.1B	
*	CN504	1-564-509-11 PLUG,CONNECTOR	6P			D313	8-719-929-15	DIODE MTZJ-T-77-9.1B	
*	CN505	1-564-510-11 PLUG,CONNECTOR	7P			D320	8-719-991-33	DIODE 1SS133T-77	
	CN600	1-695-915-11 TAB (CONTACT)				D410	8-719-404-50	DIODE MA111-TX	
*	CN906	1-564-506-11 PLUG,CONNECTOR	3P			D412	8-719-404-50	DIODE MA111-TX	
*	CN3300	1-691-616-21 CONNECTOR, BOARD TO BOARD	15P			D413	8-719-921-63	DIODE MTZJ-T-77-7.5B	
*	CN3301	1-691-616-21 CONNECTOR, BOARD TO BOARD	15P			D415	8-719-991-33	DIODE 1SS133T-77	
		DIODE				D501	8-719-109-89	DIODE MTZJ-T-77-5.6C	
	D002	8-719-921-44 DIODE MTZJ-T-77-5.1C				D502	8-719-945-80	DIODE ERC06-15S	
	D004	8-719-921-44 DIODE MTZJ-T-77-5.1C					D503	8-719-945-80 DIODE ERC06-15S	
	D005	8-719-110-17 DIODE MTZJ-T-77-10B				D504	8-719-312-10	DIODE RU4AM-T3	
	D006	8-719-110-17 DIODE MTZJ-T-77-10B				D505	8-719-908-03	DIODE GP08DPKG23	
	D007	8-719-404-50 DIODE MA111-TX				D506	8-719-908-03	DIODE GP08DPKG23	
						D507	8-719-991-33	DIODE 1SS133T-77	
							D508	8-719-991-33 DIODE 1SS133T-77	
						D510	8-719-081-93	DIODE 1N4937/23	
						D511	8-719-970-87	DIODE ERA38-06TP1	

NOTE: The components identified by shading and  mark are critical for safety. Replace only with part number specified.

NOTE: Les composants identifiés par un trame et une marque  sont critiques pour la sécurité. Ne les remplacer que par une pièce portant le numéro spécifique.













REF. NO.	PART NO.	DESCRIPTION	VALUES	REF. NO.	PART NO.	DESCRIPTION	VALUES
D512	8-719-970-87	DIODE ERA38-06TP1		JACK			
D513	8-719-110-41	DIODE MTZJ-T-77-15B		J201	1-794-119-11	TERMINAL BLOCK, S	4P
 D515	8-719-075-41	DIODE PR1004GT		J203	1-794-118-11	JACK BLOCK, PIN	3P
D516	8-719-991-33	DIODE 1SS133T-77		J204	1-794-118-11	JACK BLOCK, PIN	3P
D518	8-719-991-33	DIODE 1SS133T-77		J205	1-794-116-11	JACK BLOCK, PIN	2P
 D519	8-719-302-43	DIODE EL1Z-V1		J206	1-794-117-11	JACK BLOCK, PIN	3P
 D520	8-719-991-33	DIODE 1SS133T-77		J207	1-794-116-11	JACK BLOCK, PIN	2P
D521	8-719-921-63	DIODE MTZJ-T-77-7.5X		CHIP CONDUCTOR			
 D522	8-719-991-33	DIODE 1SS133T-77		JR1	1-216-864-11	SHORT	
D523	8-719-109-69	DIODE MTZJ-T-77-3.6B		JR2	1-216-864-11	SHORT	
D524	8-719-109-97	DIODE MTZJ-T-77-6.8B		JR4	1-216-864-11	SHORT	
 D530	8-719-979-85	DIODE RGP15GPKG23		JR5	1-216-864-11	SHORT	
D531	8-719-979-85	DIODE RGP15GPKG23		JR8	1-216-864-11	SHORT	
D534	8-719-302-43	DIODE RGP10GPKG23		JR9	1-216-864-11	SHORT	
D535	8-719-404-50	DIODE MA111-TX		JR10	1-216-864-11	SHORT	
D536	8-719-404-50	DIODE MA111-TX				(KV-32FV300/36FV300 ONLY)	
D561	8-719-075-33	DIODE 1N4003GA		JR12	1-216-864-11	SHORT	
 D580	8-719-991-33	DIODE 1SS133T-77		JR13	1-216-864-11	SHORT	
D590	8-719-991-33	DIODE 1SS133T-77		JR14	1-216-864-11	SHORT	
FERRITE BEAD				JR15	1-216-864-11	SHORT	
FB501	1-410-397-21	FERRITE	1.1µH	JR202	1-216-864-11	SHORT	
FB502	1-410-397-21	FERRITE	1.1µH	JR301	1-216-864-11	SHORT	
FB503	1-410-397-21	FERRITE	1.1µH	JR302	1-216-864-11	SHORT	
IC				JR303	1-216-864-11	SHORT	
IC001	6-801-165-01	IC M306V5ME-109SP		JR304	1-216-864-11	SHORT	
IC002	6-701-929-01	IC BD4743G-TR		JR305	1-216-864-11	SHORT	
IC003	8-759-641-86	IC BR24C16F-E2		JR306	1-216-864-11	SHORT	
IC301	8-752-100-49	IC CXA2154AS		JR401	1-216-864-11	SHORT	
IC400	6-701-106-01	IC NJW1134GK1-TE2		JR402	1-216-864-11	SHORT	
IC402	8-759-689-71	IC NJM2188M-TE2		JR403	1-216-864-11	SHORT	
IC403	6-702-114-01	IC BU4051BCF-E2		COIL			
		(KV-32FV300/36FV300 ONLY)		L001	1-410-482-31	INDUCTOR	100µH
IC404	6-702-114-01	IC BU4051BCF-E2		L002	1-410-482-31	INDUCTOR	100µH
		(KV-32FV300/36FV300 ONLY)		L003	1-412-029-11	INDUCTOR	10µH
IC501	8-759-700-07	IC NJM2903M-TE2		L004	1-410-482-31	INDUCTOR	100µH
 IC561	8-759-696-71	IC STV9379		L009	1-410-482-31	INDUCTOR	100µH
		(KV-32FV300/36FV300 ONLY)		L010	1-414-182-11	INDUCTOR	6.8µH
 IC561	8-759-980-58	IC TDA8172		L300	1-410-482-31	INDUCTOR	100µH
		(KV-27FV300/29FV300 ONLY)		L301	1-410-482-31	INDUCTOR	100µH
IC6008	6-701-752-01	IC NJM2930F05		L302	1-412-029-11	INDUCTOR	10µH
				L303	1-410-478-11	INDUCTOR	47µH

NOTE: The components identified by shading and  mark are critical for safety. Replace only with part number specified.

NOTE: Les composants identifiés par un trame et une  sont critiques pour la sécurité. Ne les remplacer que par une pièce portant le numéro spécifique.





REF. NO.	PART NO.	DESCRIPTION	VALUES	REF. NO.	PART NO.	DESCRIPTION	VALUES
L304	1-410-470-11	INDUCTOR	10μH	Q407	8-729-422-27	TRANSISTOR 2SD601A-QRS-TX	
L501	1-406-677-11	INDUCTOR	10MH	Q501	8-729-140-50	TRANSISTOR 2SC3209LK-TP	
L502	1-412-552-11	INDUCTOR	2.2MH	 Q502	6-550-107-01	TRANSISTOR 2SD2645-YB	
L503	1-406-677-11	INDUCTOR	10MH	Q507	8-729-043-95	TRANSISTOR 2SC3840K	
L504	1-406-677-11	INDUCTOR	10MH	 Q511	8-729-120-28	TRANSISTOR 2SC2412K-T-146-QR	
 L505	1-406-976-11	INDUCTOR	68μH	 Q512	8-729-809-29	TRANSISTOR 2SC4159-E	
	(KV-32FV300/36FV300 ONLY)			 Q530	8-729-422-27	TRANSISTOR 2SD601A-QRS-TX	
 L505	1-406-978-11	INDUCTOR	150μH	 Q531	8-729-424-02	TRANSISTOR 2SB709A-QRS-TX	
	(KV-27FV300/29FV300 ONLY)			 Q532	8-729-200-17	TRANSISTOR 2SA10910-TPE2	
L511	1-409-955-11	INDUCTOR	8MH	Q561	8-729-422-27	TRANSISTOR 2SD601A-QRS-TX	
L517	1-412-552-11	INDUCTOR	2.2MH	Q562	8-729-120-28	TRANSISTOR 2SC2412K-T-146-QR	
TRANSISTOR				 Q590	8-729-422-27	TRANSISTOR 2SD601A-QRS-TX	
Q001	8-729-424-02	TRANSISTOR 2SB709A-QRS-TX		Q6000	8-729-422-27	TRANSISTOR 2SD601A-QRS-TX	
Q002	8-729-422-27	TRANSISTOR 2SD601A-QRS-TX		RESISTOR			
 Q003	8-729-422-27	TRANSISTOR 2SD601A-QRS-TX		R001	1-249-429-11	CARBON	10K 5% 1/4W
Q004	8-729-422-27	TRANSISTOR 2SD601A-QRS-TX		R002	1-249-409-11	CARBON	220 5% 1/4W
Q005	8-729-422-27	TRANSISTOR 2SD601A-QRS-TX		R003	1-216-817-11	RES-CHIP	470 5% 1/10W
Q010	8-729-424-02	TRANSISTOR 2SB709A-QRS-TX		R004	1-216-857-11	RES-CHIP	1M 5% 1/10W
Q110	8-729-424-02	TRANSISTOR 2SB709A-QRS-TX		R005	1-216-821-11	RES-CHIP	1K 5% 1/10W
Q300	8-729-424-02	TRANSISTOR 2SB709A-QRS-TX		R006	1-249-417-11	CARBON	1K 5% 1/4W
Q304	8-729-422-27	TRANSISTOR 2SD601A-QRS-TX		R007	1-216-833-11	RES-CHIP	10K 5% 1/10W
Q305	8-729-424-02	TRANSISTOR 2SB709A-QRS-TX		R009	1-216-864-11	SHORT	
Q306	8-729-422-27	TRANSISTOR 2SD601A-QRS-TX		R010	1-249-409-11	CARBON	220 5% 1/4W
Q307	8-729-424-02	TRANSISTOR 2SB709A-QRS-TX		R011	1-216-821-11	RES-CHIP	1K 5% 1/10W
Q308	8-729-424-02	TRANSISTOR 2SB709A-QRS-TX		R012	1-216-827-11	RES-CHIP	3.3K 5% 1/10W
Q309	8-729-424-02	TRANSISTOR 2SB709A-QRS-TX		R013	1-216-833-11	RES-CHIP	10K 5% 1/10W
Q314	8-729-422-27	TRANSISTOR 2SD601A-QRS-TX		R015	1-216-813-11	RES-CHIP	220 5% 1/10W
Q315	8-729-424-02	TRANSISTOR 2SB709A-QRS-TX		R016	1-216-813-11	RES-CHIP	220 5% 1/10W
Q316	8-729-424-02	TRANSISTOR 2SB709A-QRS-TX		R017	1-216-813-11	RES-CHIP	220 5% 1/10W
Q317	8-729-422-27	TRANSISTOR 2SD601A-QRS-TX		R018	1-216-813-11	RES-CHIP	220 5% 1/10W
Q319	8-729-422-27	TRANSISTOR 2SD601A-QRS-TX		R019	1-216-829-11	RES-CHIP	4.7K 5% 1/10W
Q325	8-729-422-27	TRANSISTOR 2SD601A-QRS-TX		R020	1-218-688-11	METAL CHIP	680 0.50% 1/16W
Q326	8-729-424-02	TRANSISTOR 2SB709A-QRS-TX		R021	1-216-829-11	RES-CHIP	4.7K 5% 1/10W
Q400	8-729-422-27	TRANSISTOR 2SD601A-QRS-TX		R022	1-218-688-11	METAL CHIP	680 0.50% 1/16W
Q401	8-729-422-27	TRANSISTOR 2SD601A-QRS-TX		R023	1-216-829-11	RES-CHIP	4.7K 5% 1/10W
Q402	8-729-422-27	TRANSISTOR 2SD601A-QRS-TX		R024	1-218-688-11	METAL CHIP	680 0.50% 1/16W
Q403	8-729-422-27	TRANSISTOR 2SD601A-QRS-TX		R025	1-216-813-11	RES-CHIP	220 5% 1/10W
Q404	8-729-422-27	TRANSISTOR 2SD601A-QRS-TX		R027	1-216-813-11	RES-CHIP	220 5% 1/10W
	(KV-32FV300/36FV300 ONLY)			R029	1-249-409-11	CARBON	220 5% 1/4W
Q405	8-729-422-27	TRANSISTOR 2SD601A-QRS-TX		R030	1-216-841-11	RES-CHIP	47K 5% 1/10W
	(KV-32FV300/36FV300 ONLY)			R031	1-216-809-11	RES-CHIP	100 5% 1/10W
Q406	8-729-422-27	TRANSISTOR 2SD601A-QRS-TX		R032	1-216-813-11	RES-CHIP	220 5% 1/10W
	(KV-32FV300/36FV300 ONLY)			R033	1-249-417-11	CARBON	1K 5% 1/4W

NOTE: The components identified by shading and  mark are critical for safety. Replace only with part number specified.

NOTE: Les composants identifiés par un trame et une  sont critiques pour la sécurité. Ne les remplacer que par une pièce portant le numéro spécifique.



REF. NO.	PART NO.	DESCRIPTION	VALUES			REF. NO.	PART NO.	DESCRIPTION	VALUES		
R034	1-216-813-11	RES-CHIP	220	5%	1/10W	R111	1-216-809-11	RES-CHIP	100	5%	1/10W
R035	1-216-813-11	RES-CHIP	220	5%	1/10W	R113	1-247-807-31	CARBON	100	5%	1/4W
R037	1-216-829-11	RES-CHIP	4.7K	5%	1/10W	R114	1-249-409-11	CARBON	220	5%	1/4W
R038	1-249-417-11	CARBON	1K	5%	1/4W	R117	1-216-837-11	RES-CHIP	22K	5%	1/10W
R039	1-216-829-11	RES-CHIP	4.7K	5%	1/10W	R118	1-216-837-11	RES-CHIP	22K	5%	1/10W
R048	1-216-829-11	RES-CHIP	4.7K	5%	1/10W	R120	1-249-413-11	CARBON	470	5%	1/4W
R050	1-216-833-11	RES-CHIP	10K	5%	1/10W	R123	1-249-421-11	CARBON	2.2K	5%	1/4W
R051	1-216-857-11	RES-CHIP	1M	5%	1/10W		(KV-32FV300/36FV300 ONLY)				
R052	1-216-845-11	RES-CHIP	100K	5%	1/10W	R124	1-216-813-11	RES-CHIP	220	5%	1/10W
R053	1-216-821-11	RES-CHIP	1K	5%	1/10W		(KV-32FV300/36FV300 ONLY)				
R054	1-249-417-11	CARBON	1K	5%	1/4W	R125	1-249-421-11	CARBON	2.2K	5%	1/4W
R055	1-216-841-11	RES-CHIP	47K	5%	1/10W		(KV-32FV300/36FV300 ONLY)				
R056	1-216-813-11	RES-CHIP	220	5%	1/10W	R126	1-216-813-11	RES-CHIP	220	5%	1/10W
R057	1-216-845-11	RES-CHIP	100K	5%	1/10W		(KV-32FV300/36FV300 ONLY)				
R058	1-216-845-11	RES-CHIP	100K	5%	1/10W	R127	1-249-421-11	CARBON	2.2K	5%	1/4W
							(KV-32FV300/36FV300 ONLY)				
R060	1-249-409-11	CARBON	220	5%	1/4W	R128	1-216-813-11	RES-CHIP	220	5%	1/10W
R061	1-249-437-11	CARBON	47K	5%	1/4W		(KV-32FV300/36FV300 ONLY)				
 R063	1-216-829-11	RES-CHIP	4.7K	5%	1/10W	R129	1-249-409-11	CARBON	220	5%	1/4W
R064	1-216-813-11	RES-CHIP	220	5%	1/10W	R130	1-216-829-11	RES-CHIP	4.7K	5%	1/10W
R065	1-216-841-11	RES-CHIP	47K	5%	1/10W	R131	1-216-813-11	RES-CHIP	220	5%	1/10W
R066	1-249-429-11	CARBON	10K	5%	1/4W	R132	1-216-829-11	RES-CHIP	4.7K	5%	1/10W
R068	1-216-833-11	RES-CHIP	10K	5%	1/10W	R133	1-216-841-11	RES-CHIP	47K	5%	1/10W
R070	1-216-813-11	RES-CHIP	220	5%	1/10W	R134	1-216-813-11	RES-CHIP	220	5%	1/10W
R071	1-216-841-11	RES-CHIP	47K	5%	1/10W	R135	1-216-813-11	RES-CHIP	220	5%	1/10W
R073	1-249-425-11	CARBON	4.7K	5%	1/4W	R136	1-249-425-11	CARBON	4.7K	5%	1/4W
R074	1-249-417-11	CARBON	1K	5%	1/4W	R137	1-216-829-11	RES-CHIP	4.7K	5%	1/10W
R075	1-216-813-11	RES-CHIP	220	5%	1/10W	R139	1-216-813-11	RES-CHIP	220	5%	1/10W
R076	1-216-841-11	RES-CHIP	47K	5%	1/10W	R140	1-249-409-11	CARBON	220	5%	1/4W
R077	1-216-809-11	RES-CHIP	100	5%	1/10W	R145	1-249-401-11	CARBON	47	5%	1/4W
R078	1-216-841-11	RES-CHIP	47K	5%	1/10W	R201	1-216-864-11	SHORT			
 R080	1-216-829-11	RES-CHIP	4.7K	5%	1/10W	R202	1-249-409-11	CARBON	220	5%	1/4W
R085	1-215-924-00	METAL OXIDE	15K	5%	3W	R203	1-216-864-11	SHORT			
R086	1-216-839-11	RES-CHIP	33K	5%	1/10W	R206	1-249-409-11	CARBON	220	5%	1/4W
R087	1-216-837-11	RES-CHIP	22K	5%	1/10W	R207	1-216-845-11	RES-CHIP	100K	5%	1/10W
R089	1-216-829-11	RES-CHIP	4.7K	5%	1/10W	R208	1-249-409-11	CARBON	220	5%	1/4W
R098	1-216-821-11	RES-CHIP	1K	5%	1/10W	R209	1-216-845-11	RES-CHIP	100K	5%	1/10W
R099	1-216-809-11	RES-CHIP	100	5%	1/10W	R210	1-216-813-11	RES-CHIP	220	5%	1/10W
R101	1-216-829-11	RES-CHIP	4.7K	5%	1/10W	R217	1-216-845-11	RES-CHIP	100K	5%	1/10W
R102	1-216-829-11	RES-CHIP	4.7K	5%	1/10W	R218	1-216-845-11	RES-CHIP	100K	5%	1/10W
R103	1-249-425-11	CARBON	4.7K	5%	1/4W	R219	1-216-813-11	RES-CHIP	220	5%	1/10W
R104	1-216-813-11	RES-CHIP	220	5%	1/10W	R220	1-216-813-11	RES-CHIP	220	5%	1/10W
R107	1-216-809-11	RES-CHIP	100	5%	1/10W	R222	1-216-845-11	RES-CHIP	100K	5%	1/10W
R108	1-216-809-11	RES-CHIP	100	5%	1/10W	R223	1-216-813-11	RES-CHIP	220	5%	1/10W
R110	1-247-807-31	CARBON	100	5%	1/4W						

























REF. NO.	PART NO.	DESCRIPTION	VALUES			REF. NO.	PART NO.	DESCRIPTION	VALUES		
R224	1-249-409-11	CARBON	220	5%	1/4W	R343	1-216-833-11	RES-CHIP	10K	5%	1/10W
R225	1-216-845-11	RES-CHIP	100K	5%	1/10W	R344	1-216-853-11	RES-CHIP	470K	5%	1/10W
R228	1-216-845-11	RES-CHIP	100K	5%	1/10W	R345	1-216-845-11	RES-CHIP	100K	5%	1/10W
R229	1-216-845-11	RES-CHIP	100K	5%	1/10W	R346	1-216-845-11	RES-CHIP	100K	5%	1/10W
R230	1-249-409-11	CARBON	220	5%	1/4W	R347	1-216-825-11	RES-CHIP	2.2K	5%	1/10W
R231	1-216-813-11	RES-CHIP	220	5%	1/10W	R348	1-216-825-11	RES-CHIP	2.2K	5%	1/10W
R232	1-216-853-11	RES-CHIP	470K	5%	1/10W	R349	1-216-864-11	SHORT			
R233	1-216-853-11	RES-CHIP	470K	5%	1/10W	R350	1-216-825-11	RES-CHIP	2.2K	5%	1/10W
R234	1-216-813-11	RES-CHIP	220	5%	1/10W	R351	1-216-864-11	SHORT			
R235	1-216-813-11	RES-CHIP	220	5%	1/10W	R352	1-216-864-11	SHORT			
R300	1-216-864-11	SHORT				R353	1-218-867-11	RES-CHIP	6.8K	5%	1/10W
R301	1-216-809-11	RES-CHIP	100	5%	1/10W	R354	1-249-425-11	CARBON	4.7K	5%	1/4W
R302	1-216-817-11	RES-CHIP	470	5%	1/10W	R359	1-216-833-11	RES-CHIP	10K	5%	1/10W
R303	1-249-414-11	CARBON	560	5%	1/4W	R368	1-216-864-11	SHORT			
R306	1-216-843-11	RES-CHIP	68K	5%	1/10W	R369	1-216-809-11	RES-CHIP	100	5%	1/10W
R307	1-216-843-11	RES-CHIP	68K	5%	1/10W	R370	1-216-809-11	RES-CHIP	100	5%	1/10W
R308	1-249-429-11	CARBON	10K	5%	1/4W	R372	1-216-864-11	SHORT			
R309	1-216-864-11	SHORT				R374	1-216-833-11	RES-CHIP	10K	5%	1/10W
R320	1-216-864-11	SHORT				R376	1-216-809-11	RES-CHIP	100	5%	1/10W
R322	1-216-829-11	RES-CHIP	4.7K	5%	1/10W	R378	1-216-809-11	RES-CHIP	100	5%	1/10W
R325	1-247-807-31	CARBON	100	5%	1/4W	R379	1-216-809-11	RES-CHIP	100	5%	1/10W
R328	1-216-833-11	RES-CHIP	10K	5%	1/10W	R380	1-216-809-11	RES-CHIP	100	5%	1/10W
R329	1-247-807-31	CARBON	100	5%	1/4W	R381	1-216-821-11	RES-CHIP	1K	5%	1/10W
R331	1-218-716-11	METAL CHIP	10K	0.50%	1/16W	R382	1-218-867-11	RES-CHIP	6.8K	5%	1/10W
R332	1-216-809-11	RES-CHIP	100	5%	1/10W	R383	1-249-421-11	CARBON	2.2K	5%	1/4W
R333	1-216-809-11	RES-CHIP	100	5%	1/10W	R384	1-216-840-11	RES-CHIP	39K	5%	1/10W
R334	1-216-821-11	RES-CHIP	1K	5%	1/10W	R385	1-216-813-11	RES-CHIP	220	5%	1/10W
R335	1-216-821-11	RES-CHIP	1K	5%	1/10W	R386	1-216-845-11	RES-CHIP	100K	5%	1/10W
R336	1-216-809-11	RES-CHIP	100	5%	1/10W	R387	1-216-864-11	SHORT			
R337	1-249-417-11	CARBON	1K	5%	1/4W	R388	1-216-821-11	RES-CHIP	1K	5%	1/10W
R338	1-216-864-11	SHORT				R389	1-216-864-11	SHORT			
R339	1-216-840-11 (KV-32FV300/36FV300 ONLY)	RES-CHIP	39K	5%	1/10W	R390	1-218-285-11	RES-CHIP	75	5%	1/10W
R339	1-216-851-11 (KV-27FV300/29FV300 ONLY)	RES-CHIP	330K	5%	1/10W	R391	1-218-285-11	RES-CHIP	75	5%	1/10W
R340	1-216-861-11 (KV-27FV300/29FV300 ONLY)	RES-CHIP	2.2M	5%	1/10W	R393	1-218-285-11	RES-CHIP	75	5%	1/10W
R340	1-216-863-11 (KV-32FV300/36FV300 ONLY)	RES-CHIP	3.3M	5%	1/10W	R394	1-218-285-11	RES-CHIP	75	5%	1/10W
R341	1-216-842-11 (KV-27FV300/29FV300 ONLY)	RES-CHIP	56K	5%	1/10W	R395	1-218-285-11	RES-CHIP	75	5%	1/10W
R341	1-216-851-11 (KV-32FV300/36FV300 ONLY)	RES-CHIP	330K	5%	1/10W	R396	1-216-853-11	RES-CHIP	470K	5%	1/10W
R342	1-216-839-11	RES-CHIP	33K	5%	1/10W	R397	1-249-417-11	CARBON	1K	5%	1/4W
						R398	1-216-841-11	RES-CHIP	47K	5%	1/10W
						R399	1-216-845-11	RES-CHIP	100K	5%	1/10W
						R400	1-216-829-11	RES-CHIP	4.7K	5%	1/10W
						R401	1-216-809-11	RES-CHIP	100	5%	1/10W
						R402	1-216-829-11 (KV-32FV300/36FV300 ONLY)	RES-CHIP	4.7K	5%	1/10W

NOTE: The components identified by shading and  mark are critical for safety. Replace only with part number specified.

A component identified by this  symbol indicates that it has been carefully factory-selected to satisfy regulations regarding X-ray radiation. Should replacement be required, replace only with the value originally used.



REF. NO.	PART NO.	DESCRIPTION	VALUES			REF. NO.	PART NO.	DESCRIPTION	VALUES		
R403	1-216-809-11	RES-CHIP	100	5%	1/10W	 R516	1-218-867-11	RES-CHIP	6.8K	5%	1/10W
R404	1-216-829-11	RES-CHIP	4.7K	5%	1/10W		(KV-36FV300 ONLY)				
R405	1-216-825-11	RES-CHIP	2.2K	5%	1/10W	R517	1-249-417-11	CARBON	1K	5%	1/4W
R406	1-216-825-11	RES-CHIP	2.2K	5%	1/10W	R518	1-216-833-11	RES-CHIP	10K	5%	1/10W
R407	1-216-825-11	RES-CHIP	2.2K	5%	1/10W	R519	1-249-413-11	CARBON	470	5%	1/4W
R408	1-216-825-11	RES-CHIP	2.2K	5%	1/10W	R520	1-215-907-11	METAL OXIDE	22	5%	3W
R409	1-249-407-11	CARBON	150	5%	1/4W	 R523	1-216-834-11	RES-CHIP	12K	5%	1/10W
R411	1-216-817-11	RES-CHIP	470	5%	1/10W		(KV-32FV300/36FV300 ONLY)				
R412	1-216-821-11	RES-CHIP	1K	5%	1/10W	 R523	1-216-837-11	RES-CHIP	22K	5%	1/10W
R413	1-216-833-11	RES-CHIP	10K	5%	1/10W		(KV-27FV300/29FV300 ONLY)				
R416	1-216-829-11	RES-CHIP	4.7K	5%	1/10W	 R524	1-249-429-11	CARBON	10K	5%	1/4W
R420	1-216-824-11	RES-CHIP	1.8K	5%	1/10W	 R525	1-249-428-11	CARBON	8.2K	5%	1/4W
R421	1-216-846-11	RES-CHIP	120K	5%	1/10W	R526	1-215-905-11	METAL OXIDE	10	5%	3W
R422	1-216-861-11	RES-CHIP	2.2M	5%	1/10W		(KV-32FV300/36FV300 ONLY)				
R423	1-216-839-11	RES-CHIP	33K	5%	1/10W	R526	1-216-377-11	METAL OXIDE	4.7	5%	2W
R424	1-216-843-11	RES-CHIP	68K	5%	1/10W		(KV-27FV300/29FV300 ONLY)				
R425	1-216-842-11	RES-CHIP	56K	5%	1/10W	 R528	1-216-837-11	RES-CHIP	22K	5%	1/10W
R426	1-216-823-11	RES-CHIP	1.5K	5%	1/10W	 R529	1-216-837-11	RES-CHIP	22K	5%	1/10W
R452	1-249-409-11	CARBON	220	5%	1/4W	  R530	1-216-834-11	RES-CHIP	12K	5%	1/10W
R453	1-216-813-11	RES-CHIP	220	5%	1/10W	  R531	1-216-842-11	RES-CHIP	56K	5%	1/10W
R501	1-216-815-11	RES-CHIP	330	5%	1/10W	 R532	1-216-810-11	RES-CHIP	120	5%	1/10W
R501	1-216-817-11	RES-CHIP	470	5%	1/10W	R533	1-215-879-11	METAL OXIDE	47K	5%	1W
						 R536	1-260-288-11	CARBON	0.47	5%	1/2W
R502	1-216-829-11	RES-CHIP	4.7K	5%	1/10W	 R537	1-260-288-11	CARBON	0.47	5%	1/2W
 R503	1-249-425-11	CARBON	4.7K	5%	1/4W	R538	1-247-887-00	CARBON	220K	5%	1/4W
R504	1-215-885-00	METAL OXIDE	68	5%	2W	R540	1-216-857-11	RES-CHIP	1M	5%	1/10W
						R541	1-215-894-11	METAL OXIDE	2.2K	5%	2W
R504	1-216-455-21	METAL OXIDE	560	5%	2W	R542	1-216-485-11	METAL OXIDE	5.6K	5%	3W
						 R543	1-249-377-11	CARBON	0.47	5%	1/4W
R505	1-249-433-11	CARBON	22K	5%	1/4W	 R545	1-249-387-11	CARBON	3.3	5%	1/4W
R506	1-215-861-00	METAL OXIDE	47	5%	1W	R546	1-215-453-00	METAL	22K	1%	1/4W
R507	1-249-401-11	CARBON	47	5%	1/4W	R547	1-215-457-00	METAL	33K	1%	1/4W
R508	1-249-425-11	CARBON	4.7K	5%	1/4W	R548	1-216-485-11	METAL OXIDE	5.6K	5%	3W
 R509	1-260-328-11	CARBON	1K	5%	1/2W	R549	1-215-437-00	METAL	4.7K	1%	1/4W
 R510	1-215-883-11	METAL OXIDE	33	5%	2W	 R550	1-249-377-11	CARBON	0.47	5%	1/4W
R512	1-215-910-00	METAL OXIDE	68	5%	3W	R551	1-215-873-00	METAL OXIDE	4.7K	5%	1W
R515	1-216-836-11	RES-CHIP	18K	5%	1/10W	 R553	1-249-377-11	CARBON	0.47	5%	1/4W
 R516	1-216-830-11	RES-CHIP	5.6K	5%	1/10W	R554	1-215-876-00	METAL OXIDE	15K	5%	1W
							(KV-27FV300/29FV300 ONLY)				
 R516	1-216-832-11	RES-CHIP	8.2K	5%	1/10W	R554	1-215-894-11	METAL OXIDE	2.2K	5%	2W
							(KV-32FV300 ONLY)				
						R555	1-249-441-11	CARBON	100K	5%	1/4W
						R556	1-249-441-11	CARBON	100K	5%	1/4W
						R557	1-249-441-11	CARBON	100K	5%	1/4W



NOTE: The components identified by shading and mark are critical for safety. Replace only with part number specified.

NOTE: Les composants identifiés par un trame et une marque sont critiques pour la sécurité. Ne les remplacer que par une pièce portant le numéro spécifique.

REF. NO.	PART NO.	DESCRIPTION	VALUES			REF. NO.	PART NO.	DESCRIPTION	VALUES		
R559	1-216-805-11	RES-CHIP	47	5%	1/10W	R932	1-218-285-11	RES-CHIP	75	5%	1/10W
R561	1-249-429-11	CARBON	10K	5%	1/4W	R933	1-218-285-11	RES-CHIP	75	5%	1/10W
⚠ R563	1-214-798-21	METAL	1.8	1%	1/2W	R934	1-218-285-11	RES-CHIP	75	5%	1/10W
⚠ R564	1-247-895-91	CARBON	470K	5%	1/4W	R940	1-247-807-31	CARBON	100	5%	1/4W
R565	1-215-889-00	METAL OXIDE	330	5%	2W	R941	1-247-807-31	CARBON	100	5%	1/4W
R566	1-218-867-11	RES-CHIP	6.8K	5%	1/10W	R942	1-216-841-11	RES-CHIP	47K	5%	1/10W
⚠ R567	1-249-385-11	CARBON	2.2	5%	1/4W	R947	1-216-864-11	SHORT			
R568	1-218-867-11	RES-CHIP	6.8K	5%	1/10W	R950	1-216-809-11	RES-CHIP	100	5%	1/10W
R569	1-249-429-11	CARBON	10K	5%	1/4W	R951	1-216-813-11	RES-CHIP	220	5%	1/10W
R570	1-216-845-11	RES-CHIP	100K	5%	1/10W	R6001	1-216-833-11	RES-CHIP	10K	5%	1/10W
R571	1-216-837-11	RES-CHIP	22K	5%	1/10W	R6002	1-216-833-11	RES-CHIP	10K	5%	1/10W
R572	1-216-837-11	RES-CHIP	22K	5%	1/10W	R6003	1-216-833-11	RES-CHIP	10K	5%	1/10W
R573	1-216-845-11	RES-CHIP	100K	5%	1/10W	R6004	1-216-821-11	RES-CHIP	1K	5%	1/10W
⚠ R574	1-214-798-21	METAL	1.8	1%	1/2W	SWITCH					
R576	1-215-905-11	METAL OXIDE (KV-32FV300/36FV300 ONLY)	10	5%	3W	S501	1-572-707-11	SWITCH LEVER			
R576	1-215-907-11	METAL OXIDE (KV-27FV300/29FV300 ONLY)	22	5%	3W	S502	1-572-707-11	SWITCH LEVER			
R577	1-216-821-11	RES-CHIP	1K	5%	1/10W	TRANSFORMER					
R578	1-214-798-21	METAL	1.8	1%	1/2W	T501	1-433-836-11	TRANSFORMER, HORIZONTAL DRIVE			
R580	1-249-441-11	CARBON	100K	5%	1/4W	⚠ T502	1-426-981-11	TRANSFORMER, FERRITE (PMT)			
R581	1-247-887-00	CARBON	220K	5%	1/4W	⚠ T503	1-453-310-11	FBT ASSY, NX-4521//X4J4 (KV-27FV300/29FV300 ONLY)			
⚠ R590	1-216-809-11	RES-CHIP	100	5%	1/10W	⚠ T503	1-453-338-21	FBT ASSY, NX-4600//X4C4 (KV-36FV300 ONLY)			
⚠ R591	1-249-417-11	CARBON	1K	5%	1/4W	⚠ T503	1-453-338-31	FBT ASSY, NX-4600//X4J4 (KV-32FV300 ONLY)			
⚠ R592	1-216-363-00	METAL OXIDE	0.33	5%	2W	⚠ T504	1-424-584-11	TRANSFORMER, DYNAMIC FOCUS			
⚠ R593	1-249-420-11	CARBON	1.8K	5%	1/4W	⚠ T505	1-431-693-11	TRANSFORMER, HORIZONTAL LINEAR (KV-27FV300/29FV300 ONLY)			
⚠ R594	1-249-429-11	CARBON	10K	5%	1/4W	⚠ T505	1-435-098-11	TRANSFORMER, HORIZONTAL LINEAR (KV-32FV300/36FV300 ONLY)			
⚠ R595	1-247-891-00	CARBON	330K	5%	1/4W	THERMISTOR					
⚠ R596	1-249-441-11	CARBON	100K	5%	1/4W	TH501	1-800-193-00	THERMISTOR			
⚠ R597	1-216-864-11	SHORT				TUNER					
⚠ R598	1-218-867-11	RES-CHIP	6.8K	5%	1/10W	☞ TU001	8-598-593-00	TUNER, FSS BTF-WA421			
⚠ R599	1-216-825-11	RES-CHIP	2.2K	5%	1/10W	CRYSTAL					
R900	1-216-821-11	RES-CHIP	1K	5%	1/10W	X001	1-781-931-21	VIBRATOR, CRYSTAL			
R901	1-216-823-11	RES-CHIP	1.5K	5%	1/10W	X301	1-567-505-11	OSCILLATOR, CRYSTAL			
R902	1-216-809-11	RES-CHIP	100	5%	1/10W						
R903	1-216-825-11	RES-CHIP	2.2K	5%	1/10W						
R904	1-216-818-11	RES-CHIP	560	5%	1/10W						
R905	1-216-817-11	RES-CHIP	470	5%	1/10W						
R906	1-249-417-11	CARBON	1K	5%	1/4W						
R907	1-216-833-11	RES-CHIP	10K	5%	1/10W						
R908	1-216-829-11	RES-CHIP	4.7K	5%	1/10W						
R909	1-249-417-11	CARBON	1K	5%	1/4W						
R910	1-216-833-11	RES-CHIP	10K	5%	1/10W						
R912	1-249-417-11	CARBON	1K	5%	1/4W						



REF. NO.	PART NO.	DESCRIPTION	VALUES	REF. NO.	PART NO.	DESCRIPTION	VALUES
BC							
*	A-1400-450-A	BC BOARD, MOUNTED					
	CAPACITOR						
C3355	1-162-964-11	CERAMIC CHIP	0.001μF 10% 50V	C3532	1-126-964-11	ELECT	10μF 20% 50V
C3356	1-126-964-11	ELECT	10μF 20% 50V	C3533	1-164-315-11	CERAMIC CHIP	470pF 5% 50V
C3357	1-113-619-11	CERAMIC CHIP	0.47μF 10V	C3534	1-126-960-11	ELECT	1μF 20% 50V
C3358	1-126-940-11	ELECT	330μF 20% 25V	C3535	1-162-917-11	CERAMIC CHIP	15pF 5% 50V
C3359	1-107-826-11	CERAMIC CHIP	0.1μF 10% 16V	C3536	1-126-960-11	ELECT	1μF 20% 50V
C3360	1-162-970-11	CERAMIC CHIP	0.01μF 10% 25V	C3537	1-126-964-11	ELECT	10μF 20% 50V
C3361	1-162-922-11	CERAMIC CHIP	39pF 5% 50V	C3538	1-162-917-11	CERAMIC CHIP	15pF 5% 50V
C3369	1-126-967-11	ELECT	47μF 20% 50V	C3539	1-162-917-11	CERAMIC CHIP	15pF 5% 50V
C3370	1-126-964-11	ELECT	10μF 20% 50V	C3541	1-162-921-11	CERAMIC CHIP	33pF 5% 50V
C3371	1-107-826-11	CERAMIC CHIP	0.1μF 10% 16V	C3542	1-126-964-11	ELECT	10μF 20% 50V
C3398	1-126-961-11	ELECT	2.2μF 20% 50V	C3543	1-135-834-91	CERAMIC CHIP	2.2μF 6.3V
C3504	1-162-920-11	CERAMIC CHIP	27pF 5% 50V	C3546	1-162-917-11	CERAMIC CHIP	15pF 5% 50V
C3505	1-162-920-11	CERAMIC CHIP	27pF 5% 50V	C3547	1-126-934-11	ELECT	220μF 20% 10V
C3506	1-164-360-11	CERAMIC CHIP	0.1μF 16V	C3548	1-107-826-11	CERAMIC CHIP	0.1μF 10% 16V
C3507	1-164-360-11	CERAMIC CHIP	0.1μF 16V	C3549	1-126-947-11	ELECT	47μF 20% 16V
C3509	1-164-360-11	CERAMIC CHIP	0.1μF 16V	C3550	1-162-974-11	CERAMIC CHIP	0.01μF 50V
C3510	1-164-392-11	CERAMIC CHIP	390pF 5% 50V	C3551	1-126-947-11	ELECT	47μF 20% 16V
C3511	1-164-360-11	CERAMIC CHIP	0.1μF 16V	C3552	1-162-974-11	CERAMIC CHIP	0.01μF 50V
C3512	1-164-360-11	CERAMIC CHIP	0.1μF 16V	C3553	1-162-974-11	CERAMIC CHIP	0.01μF 50V
C3513	1-216-864-11	SHORT		C3554	1-126-960-11	ELECT	1μF 20% 50V
C3514	1-162-974-11	CERAMIC CHIP	0.01μF 50V	C3555	1-126-934-11	ELECT	220μF 20% 10V
C3515	1-164-360-11	CERAMIC CHIP	0.1μF 16V	C3556	1-107-826-11	CERAMIC CHIP	0.1μF 10% 16V
C3516	1-164-360-11	CERAMIC CHIP	0.1μF 16V	C3557	1-162-974-11	CERAMIC CHIP	0.01μF 50V
C3517	1-126-924-11	ELECT	330μF 20% 6.3V	C3558	1-126-947-11	ELECT	47μF 20% 16V
C3518	1-164-360-11	CERAMIC CHIP	0.1μF 16V	C3559	1-162-974-11	CERAMIC CHIP	0.01μF 50V
C3519	1-164-360-11	CERAMIC CHIP	0.1μF 16V	C3560	1-126-947-11	ELECT	47μF 20% 16V
C3520	1-164-360-11	CERAMIC CHIP	0.1μF 16V	C3561	1-162-974-11	CERAMIC CHIP	0.01μF 50V
C3521	1-162-920-11	CERAMIC CHIP	27pF 5% 50V	C3562	1-162-974-11	CERAMIC CHIP	0.01μF 50V
C3522	1-126-947-11	ELECT	47μF 20% 16V	C3563	1-126-947-11	ELECT	47μF 20% 16V
C3523	1-164-360-11	CERAMIC CHIP	0.1μF 16V	C3564	1-126-947-11	ELECT	47μF 20% 16V
C3524	1-164-360-11	CERAMIC CHIP	0.1μF 16V	C3565	1-162-974-11	CERAMIC CHIP	0.01μF 50V
C3525	1-164-360-11	CERAMIC CHIP	0.1μF 16V	C3566	1-162-974-11	CERAMIC CHIP	0.01μF 50V
C3526	1-164-360-11	CERAMIC CHIP	0.1μF 16V	C3580	1-126-940-11	ELECT	330μF 20% 25V
C3527	1-164-360-11	CERAMIC CHIP	0.1μF 16V	C3581	1-107-826-11	CERAMIC CHIP	0.1μF 10% 16V
C3528	1-164-360-11	CERAMIC CHIP	0.1μF 16V	C3582	1-126-934-11	ELECT	220μF 20% 10V
C3529	1-164-360-11	CERAMIC CHIP	0.1μF 16V	C3583	1-126-934-11	ELECT	220μF 20% 10V
C3530	1-126-947-11	ELECT	47μF 20% 16V	C3585	1-107-826-11	CERAMIC CHIP	0.1μF 10% 16V
C3531	1-164-360-11	CERAMIC CHIP	0.1μF 16V	C3590	1-104-665-11	ELECT	100μF 20% 25V
				CONNECTOR			
				CN3500	1-573-301-21	CONNECTOR, BOARD TO BOARD 20P	



REF. NO.	PART NO.	DESCRIPTION	VALUES	REF. NO.	PART NO.	DESCRIPTION	VALUES
DIODE				TRANSISTOR			
D3550	8-719-977-28	DIODE UDZSTE-1710B		Q3500	8-729-424-02	TRANSISTOR 2SB709A-QRS-TX	
FERRITE BEAD				Q3501	8-729-422-27	TRANSISTOR 2SD601A-QRS-TX	
FB3502	1-414-234-22	FERRITE	0μH	Q3502	8-729-424-02	TRANSISTOR 2SB709A-QRS-TX	
FB3503	1-414-234-22	FERRITE	0μH	Q3503	8-729-422-27	TRANSISTOR 2SD601A-QRS-TX	
FB3504	1-414-234-22	FERRITE	0μH	Q3504	8-729-424-02	TRANSISTOR 2SB709A-QRS-TX	
FB3505	1-414-234-22	FERRITE	0μH	Q3505	8-729-422-27	TRANSISTOR 2SD601A-QRS-TX	
FB3506	1-414-234-22	FERRITE	0μH	Q3506	8-729-422-27	TRANSISTOR 2SD601A-QRS-TX	
FB3507	1-414-234-22	FERRITE	0μH	Q3508	8-729-422-27	TRANSISTOR 2SD601A-QRS-TX	
FB3508	1-414-234-22	FERRITE	0μH	Q3509	8-729-424-02	TRANSISTOR 2SB709A-QRS-TX	
FB3509	1-414-234-22	FERRITE	0μH	Q3510	8-729-424-02	TRANSISTOR 2SB709A-QRS-TX	
FILTER				Q3511	8-729-422-27	TRANSISTOR 2SD601A-QRS-TX	
FL3500	1-239-848-21	FILTER, LOW PASS		Q3512	8-729-422-27	TRANSISTOR 2SD601A-QRS-TX	
FL3501	1-239-848-21	FILTER, LOW PASS		Q3513	8-729-422-27	TRANSISTOR 2SD601A-QRS-TX	
FL3502	1-239-848-21	FILTER, LOW PASS		Q3514	8-729-424-02	TRANSISTOR 2SB709A-QRS-TX	
FL3503	1-239-848-21	FILTER, LOW PASS		Q3515	8-729-422-27	TRANSISTOR 2SD601A-QRS-TX	
FL3504	1-233-736-21	FILTER, EMI		Q3516	8-729-422-27	TRANSISTOR 2SD601A-QRS-TX	
FL3505	1-233-736-21	FILTER, EMI		Q3517	8-729-422-27	TRANSISTOR 2SD601A-QRS-TX	
FL3506	1-233-736-21	FILTER, EMI		Q3590	8-729-926-14	TRANSISTOR 2SD1292	
IC				RESISTOR			
IC3501	6-700-960-01	IC UPD64083GF-3BA		R3301	1-216-805-11	RES-CHIP	47 5% 1/10W
IC3502	8-759-462-91	IC TA1226N		R3302	1-216-805-11	RES-CHIP	47 5% 1/10W
IC3503	8-759-583-47	IC UPC2933T-E1		R3303	1-216-833-11	RES-CHIP	10K 5% 1/10W
IC3504	6-700-394-01	IC BA25BC0FP-E2		R3364	1-216-845-11	RES-CHIP	100K 5% 1/10W
IC3505	8-759-394-35	IC BA12T		R3365	1-216-841-11	RES-CHIP	47K 5% 1/10W
CHIP CONDUCTOR				R3366	1-216-850-11	RES-CHIP	270K 5% 1/10W
JR3301	1-216-864-11	SHORT		R3369	1-216-843-11	RES-CHIP	68K 5% 1/10W
JR3302	1-216-864-11	SHORT		R3373	1-216-809-11	RES-CHIP	100 5% 1/10W
JR3501	1-216-864-11	SHORT		R3505	1-216-864-11	SHORT	
COIL				R3506	1-216-864-11	SHORT	
L3352	1-414-186-31	INDUCTOR	33μH	R3507	1-216-864-11	SHORT	
L3500	1-414-265-21	INDUCTOR	4.7μH	R3508	1-216-864-11	SHORT	
L3501	1-412-058-11	INDUCTOR	10μH	R3509	1-216-821-11	RES-CHIP	1K 5% 1/10W
L3502	1-412-058-11	INDUCTOR	10μH	R3510	1-216-817-11	RES-CHIP	470 5% 1/10W
L3503	1-412-058-11	INDUCTOR	10μH	R3511	1-216-817-11	RES-CHIP	470 5% 1/10W
L3504	1-412-058-11	INDUCTOR	10μH	R3514	1-216-809-11	RES-CHIP	100 5% 1/10W
L3505	1-412-058-11	INDUCTOR	10μH	R3515	1-216-824-11	RES-CHIP	1.8K 5% 1/10W
				R3516	1-216-824-11	RES-CHIP	1.8K 5% 1/10W
				R3517	1-216-809-11	RES-CHIP	100 5% 1/10W
				R3518	1-216-809-11	RES-CHIP	100 5% 1/10W
				R3519	1-216-864-11	SHORT	
				R3520	1-218-708-11	METAL CHIP	4.7K 0.50% 1/16W



REF. NO.	PART NO.	DESCRIPTION	VALUES			REF. NO.	PART NO.	DESCRIPTION	VALUES		
R2238	1-249-441-11	CARBON	100K	5%	1/4W	C3321	1-113-619-11	CERAMIC CHIP	0.47μF		10V
R2239	1-247-804-11	CARBON	75	5%	1/4W	C3322	1-164-373-11	CERAMIC CHIP	0.033μF		25V
R2240	1-247-804-11	CARBON	75	5%	1/4W	C3323	1-127-715-91	CERAMIC CHIP	0.22μF	10%	16V
R2241	1-247-804-11	CARBON	75	5%	1/4W	C3324	1-162-918-11	CERAMIC CHIP	18pF	5%	50V
						C3327	1-164-315-11	CERAMIC CHIP	470pF	5%	50V
		SWITCH				C3328	1-162-970-11	CERAMIC CHIP	0.01μF	10%	25V
S1007	1-762-816-11	SWITCH TACTILE				C3329	1-164-315-11	CERAMIC CHIP	470pF	5%	50V
S1008	1-762-816-11	SWITCH TACTILE				C3330	1-162-970-11	CERAMIC CHIP	0.01μF	10%	25V
S2001	1-692-431-21	SWITCH TACTILE				C3331	1-162-970-11	CERAMIC CHIP	0.01μF	10%	25V
S2002	1-692-431-21	SWITCH TACTILE				C3332	1-162-970-11	CERAMIC CHIP	0.01μF	10%	25V
S2003	1-692-431-21	SWITCH TACTILE				C3334	1-162-970-11	CERAMIC CHIP	0.01μF	10%	25V
S2004	1-692-431-21	SWITCH TACTILE				C3335	1-164-360-11	CERAMIC CHIP	0.1μF		16V
S2005	1-692-431-21	SWITCH TACTILE				C3336	1-162-970-11	CERAMIC CHIP	0.01μF	10%	25V
						C3337	1-164-360-11	CERAMIC CHIP	0.1μF		16V
						C3338	1-164-360-11	CERAMIC CHIP	0.1μF		16V
						C3339	1-126-965-91	ELECT	22μF	20%	50V
						C3340	1-126-947-11	ELECT	47μF	20%	16V
						C3341	1-162-970-11	CERAMIC CHIP	0.01μF	10%	25V
						C3390	1-104-665-11	ELECT	100μF	20%	25V
						C3391	1-104-665-11	ELECT	100μF	20%	25V
								CONNECTOR			
						* CN3302	1-691-632-21	CONNECTOR, BOARD TO BOARD 15P			
						* CN3303	1-691-632-21	CONNECTOR, BOARD TO BOARD 15P			
						CN6600	1-695-915-11	TAB (CONTACT)			
								DIODE			
						D103	8-719-404-50	DIODE MA111-TX			
						D104	8-719-404-50	DIODE MA111-TX			
						D3301	8-719-404-50	DIODE MA111-TX			
						D3304	8-719-109-72	DIODE MTZJ-T-77-3.9B			
								IC			
						IC3301	6-701-754-01	IC M65665ASP			
						IC3390	8-759-701-59	IC NJM78M09FA			
								CHIP CONDUCTOR			
						JR001	1-216-864-11	SHORT			
						JR002	1-216-864-11	SHORT			
								COIL			
						L150	1-414-857-11	INDUCTOR	100μH		
						L3300	1-412-058-11	INDUCTOR	10μH		
						L3301	1-410-682-31	INDUCTOR	470μH		
						L3302	1-412-058-11	INDUCTOR	10μH		

P

*

A-1400-456-A P (VAR) BOARD, MOUNTED

4-382-854-11 SCREW (M3X10), P, SW (+)

CAPACITOR

C100 1-126-968-11 ELECT 100μF 20% 50V
 C102 1-126-947-11 ELECT 47μF 20% 25V
 C103 1-126-964-11 ELECT 10μF 20% 50V
 C104 1-126-967-11 ELECT 47μF 20% 50V
 C106 1-162-968-11 CERAMIC CHIP 0.0047μF 10% 50V

C107 1-126-960-11 ELECT 1μF 20% 50V
 C109 1-164-230-11 CERAMIC CHIP 220pF 5% 50V
 C110 1-165-176-11 CERAMIC CHIP 0.047μF 10% 16V
 C111 1-126-960-11 ELECT 1μF 20% 50V
 C3300 1-115-156-11 CERAMIC CHIP 1μF 10V

C3301 1-115-156-11 CERAMIC CHIP 1μF 10V
 C3302 1-115-156-11 CERAMIC CHIP 1μF 10V
 C3303 1-126-947-11 ELECT 47μF 20% 16V
 C3304 1-164-315-11 CERAMIC CHIP 470pF 5% 50V
 C3305 1-164-360-11 CERAMIC CHIP 0.1μF 16V

C3308 1-126-947-11 ELECT 47μF 20% 16V
 C3312 1-164-315-11 CERAMIC CHIP 470pF 5% 50V
 C3313 1-162-927-11 CERAMIC CHIP 100pF 5% 50V
 C3316 1-126-947-11 ELECT 47μF 20% 16V
 C3317 1-162-970-11 CERAMIC CHIP 0.01μF 10% 25V

C3318 1-162-970-11 CERAMIC CHIP 0.01μF 10% 25V
 C3319 1-126-947-11 ELECT 47μF 20% 16V
 C3320 1-162-970-11 CERAMIC CHIP 0.01μF 10% 25V



REF. NO.	PART NO.	DESCRIPTION	VALUES			REF. NO.	PART NO.	DESCRIPTION	VALUES		
L3303	1-412-058-11	INDUCTOR	10μH			R3311	1-216-819-11	RES-CHIP	680	5%	1/10W
L3390	1-412-525-31	INDUCTOR	10μH			R3312	1-216-864-11	SHORT			
		TRANSISTOR				R3313	1-216-864-11	SHORT			
Q151	8-729-424-02	TRANSISTOR 2SB709A-QRS-TX				R3314	1-216-864-11	SHORT			
Q152	8-729-422-27	TRANSISTOR 2SD601A-QRS-TX				R3318	1-216-833-11	RES-CHIP	10K	5%	1/10W
Q3300	8-729-422-27	TRANSISTOR 2SD601A-QRS-TX				R3319	1-216-833-11	RES-CHIP	10K	5%	1/10W
Q3301	8-729-422-27	TRANSISTOR 2SD601A-QRS-TX				R3320	1-216-829-11	RES-CHIP	4.7K	5%	1/10W
Q3302	8-729-422-27	TRANSISTOR 2SD601A-QRS-TX				R3321	1-216-864-11	SHORT			
						R3323	1-249-414-11	CARBON	560	5%	1/4W
Q3304	8-729-926-14	TRANSISTOR 2SD1292				R3324	1-216-821-11	RES-CHIP	1K	5%	1/10W
Q3305	8-729-422-27	TRANSISTOR 2SD601A-QRS-TX				R3327	1-216-864-11	SHORT			
Q3307	8-729-424-02	TRANSISTOR 2SB709A-QRS-TX				R3328	1-216-821-11	RES-CHIP	1K	5%	1/10W
Q3308	8-729-424-02	TRANSISTOR 2SB709A-QRS-TX				R3329	1-216-864-11	SHORT			
Q3309	8-729-424-02	TRANSISTOR 2SB709A-QRS-TX				R3330	1-216-821-11	RES-CHIP	1K	5%	1/10W
						R3331	1-216-821-11	RES-CHIP	1K	5%	1/10W
Q3310	8-729-422-27	TRANSISTOR 2SD601A-QRS-TX									
Q3312	8-729-422-27	TRANSISTOR 2SD601A-QRS-TX				R3335	1-215-857-71	METAL OXIDE	10	5%	1W
		RESISTOR				R3336	1-216-817-11	RES-CHIP	470	5%	1/10W
R100	1-216-809-11	RES-CHIP	100	5%	1/10W	R3343	1-216-821-11	RES-CHIP	1K	5%	1/10W
R101	1-216-809-11	RES-CHIP	100	5%	1/10W	R3344	1-216-821-11	RES-CHIP	1K	5%	1/10W
R103	1-216-837-11	RES-CHIP	22K	5%	1/10W	R3346	1-216-821-11	RES-CHIP	1K	5%	1/10W
R104	1-216-839-11	RES-CHIP	33K	5%	1/10W	R3347	1-216-833-11	RES-CHIP	10K	5%	1/10W
R105	1-216-809-11	RES-CHIP	100	5%	1/10W						
						R3348	1-216-833-11	RES-CHIP	10K	5%	1/10W
R106	1-216-817-11	RES-CHIP	470	5%	1/10W	R3350	1-216-864-11	SHORT			
R107	1-216-817-11	RES-CHIP	470	5%	1/10W	R3351	1-216-813-11	RES-CHIP	220	5%	1/10W
R108	1-216-825-11	RES-CHIP	2.2K	5%	1/10W	R3354	1-216-863-11	RES-CHIP	3.3M	5%	1/10W
R112	1-216-825-11	RES-CHIP	2.2K	5%	1/10W	R3359	1-216-864-11	SHORT			
R113	1-216-845-11	RES-CHIP	100K	5%	1/10W						
						R3360	1-216-864-11	SHORT			
R114	1-216-857-11	RES-CHIP	1M	5%	1/10W	R3361	1-216-864-11	SHORT			
R115	1-216-833-11	RES-CHIP	10K	5%	1/10W	R3362	1-216-827-11	RES-CHIP	3.3K	5%	1/10W
R116	1-216-833-11	RES-CHIP	10K	5%	1/10W	R3363	1-216-839-11	RES-CHIP	33K	5%	1/10W
R117	1-216-829-11	RES-CHIP	4.7K	5%	1/10W	R3364	1-247-807-31	CARBON	100	5%	1/4W
R3300	1-216-841-11	RES-CHIP	47K	5%	1/10W						
						R3365	1-247-807-31	CARBON	100	5%	1/4W
R3301	1-216-821-11	RES-CHIP	1K	5%	1/10W	R3368	1-216-833-11	RES-CHIP	10K	5%	1/10W
R3302	1-216-841-11	RES-CHIP	47K	5%	1/10W	R3369	1-216-864-11	SHORT			
R3303	1-216-821-11	RES-CHIP	1K	5%	1/10W	R3372	1-216-864-11	SHORT			
R3304	1-216-821-11	RES-CHIP	1K	5%	1/10W	R3374	1-216-864-11	SHORT			
R3305	1-216-841-11	RES-CHIP	47K	5%	1/10W	R3390	1-216-395-00	METAL OXIDE	3.3	5%	3W
R3306	1-216-837-11	RES-CHIP	22K	5%	1/10W	TUNER					
R3307	1-216-821-11	RES-CHIP	1K	5%	1/10W	TU150	8-598-594-00	TUNER, FSS BTF-FA421			
R3308	1-216-837-11	RES-CHIP	22K	5%	1/10W						
R3309	1-216-817-11	RES-CHIP	470	5%	1/10W	CRYSTAL					
R3310	1-216-841-11	RES-CHIP	47K	5%	1/10W	X3301	1-781-377-41	VIBRATOR, CRYSTAL			



REF. NO.	PART NO.	DESCRIPTION	VALUES			REF. NO.	PART NO.	DESCRIPTION	VALUES			
HR												
*	A-1400-459-A	HR (COM) BOARD, MOUNTED				C415	1-162-970-11	CERAMIC CHIP	0.01μF	10%	25V	
CAPACITOR					C416	1-126-947-11	ELECT	47μF	20%	25V		
C3001	1-104-665-11	ELECT	100μF	20%	25V	C417	1-126-963-11	ELECT	4.7μF	20%	50V	
CONNECTOR					C418	1-162-916-11	CERAMIC CHIP	12pF	5%	50V		
CN3001	1-564-521-11	PLUG,CONNECTOR	6P			C419	1-162-915-11	CERAMIC CHIP	10pF	0.50pF	50V	
DIODE					C420	1-162-970-11	CERAMIC CHIP	0.01μF	10%	25V		
D3002	8-719-057-09	DIODE LNJ801LPDJA			C421	1-162-970-11	CERAMIC CHIP	0.01μF	10%	25V		
IC					C422	1-126-947-11	ELECT	47μF	20%	25V		
IC3001	8-742-211-20	HYB IC SBX3071-71			C423	1-162-970-11	CERAMIC CHIP	0.01μF	10%	25V		
RESISTOR					C424	1-162-970-11	CERAMIC CHIP	0.01μF	10%	25V		
R3001	1-249-417-11	CARBON	1K	5%	1/4W	C425	1-126-947-11	ELECT	47μF	20%	25V	
R3014	1-247-807-31	CARBON	100	5%	1/4W	C426	1-162-970-11	CERAMIC CHIP	0.01μF	10%	25V	
SWITCH					C427	1-126-933-11	ELECT	100μF	20%	16V		
S3006	1-572-198-11	SWITCH KEYBOARD			CONNECTOR							
T					*	CN415	1-564-520-11	PLUG,CONNECTOR	5P			
*	A-1400-460-A	T BOARD, MOUNTED				DIODE						
(KV-32FV300/36FV300 ONLY)					D401	8-719-109-89	DIODE MTZJ-T-77-5.6C					
CAPACITOR					D402	8-719-057-93	DIODE SVC203SPA-AL					
C401	1-162-923-11	CERAMIC CHIP	47pF	5%	50V	D403	8-719-057-93	DIODE SVC203SPA-AL				
C402	1-165-176-11	CERAMIC CHIP	0.047μF	10%	16V	D404	8-719-992-13	DIODE DAL5815				
C403	1-126-963-11	ELECT	4.7μF	20%	50V	D405	8-719-992-13	DIODE DAL5815				
C404	1-164-739-11	CERAMIC CHIP	560pF	5%	50V	D406	8-719-992-13	DIODE DAL5815				
C405	1-126-947-11	ELECT	47μF	20%	25V	D407	8-719-992-13	DIODE DAL5815				
C406	1-162-970-11	CERAMIC CHIP	0.01μF	10%	25V	D408	8-719-992-13	DIODE DAL5815				
C407	1-165-176-11	CERAMIC CHIP	0.047μF	10%	16V	D409	8-719-992-13	DIODE DAL5815				
C408	1-164-739-11	CERAMIC CHIP	560pF	5%	50V	D410	8-719-992-13	DIODE DAL5815				
C409	1-126-963-11	ELECT	4.7μF	20%	50V	D411	8-719-992-13	DIODE DAL5815				
C410	1-162-923-11	CERAMIC CHIP	47pF	5%	50V	IC						
C411	1-126-963-11	ELECT	4.7μF	20%	50V	IC401	8-759-939-73	IC BA3308				
C412	1-162-966-11	CERAMIC CHIP	0.0022μF	10%	50V	COIL						
C413	1-162-966-11	CERAMIC CHIP	0.0022μF	10%	50V	L401	1-411-987-11	COIL (OSC)				
C414	1-126-947-11	ELECT	47μF	20%	25V	L402	1-411-988-11	COIL (OSC)				
					L403	1-410-482-31	INDUCTOR	100μH				
					TRANSISTOR							
					Q401	8-729-266-83	TRANSISTOR 2SC2668-YTP					
					Q402	8-729-266-83	TRANSISTOR 2SC2668-YTP					
					Q403	8-729-423-33	TRANSISTOR 2SC3311A-QRSTA					
					Q404	8-729-424-02	TRANSISTOR 2SB709A-QRS-TX					
					Q405	8-729-424-02	TRANSISTOR 2SB709A-QRS-TX					





REF. NO.	PART NO.	DESCRIPTION	VALUES			REF. NO.	PART NO.	DESCRIPTION	VALUES		
Q406	8-729-931-14	TRANSISTOR 2SD1858-Q-TV2				R436	1-216-797-11	RES-CHIP	10	5%	1/10W
Q407	8-729-931-14	TRANSISTOR 2SD1858-Q-TV2				R437	1-216-797-11	RES-CHIP	10	5%	1/10W
Q408	8-729-931-14	TRANSISTOR 2SD1858-Q-TV2				R438	1-216-797-11	RES-CHIP	10	5%	1/10W
Q409	8-729-931-14	TRANSISTOR 2SD1858-Q-TV2				R439	1-216-826-11	RES-CHIP	2.7K	5%	1/10W
Q410	8-729-424-02	TRANSISTOR 2SB709A-QRS-TX				R440	1-216-864-11	SHORT			
Q411	8-729-424-02	TRANSISTOR 2SB709A-QRS-TX				R441	1-216-864-11	SHORT			
RESISTOR						R460	1-216-826-11	RES-CHIP	2.7K	5%	1/10W
R401	1-216-841-11	RES-CHIP	47K	5%	1/10W	<div style="border: 1px solid black; padding: 5px; display: inline-block; margin-bottom: 5px;">C</div> <p>* A-1400-455-A C (COM) BOARD, MOUNTED (KV-27FV300/29FV300/32FV300 ONLY)</p> <p>* A-1400-580-A C (VAR) BOARD, MOUNTED (KV-36FV300 ONLY)</p>					
R402	1-216-841-11	RES-CHIP	47K	5%	1/10W						
R403	1-216-841-11	RES-CHIP	47K	5%	1/10W						
R404	1-216-823-11	RES-CHIP	1.5K	5%	1/10W						
R405	1-216-809-11	RES-CHIP	100	5%	1/10W						
R406	1-216-823-11	RES-CHIP	1.5K	5%	1/10W	4-382-854-11	SCREW (M3X10), P, SW (+)				
R407	1-216-863-11	RES-CHIP	3.3M	5%	1/10W	CAPACITOR					
R408	1-216-841-11	RES-CHIP	47K	5%	1/10W	C701	1-126-947-11	ELECT	47µF	20%	25V
R409	1-216-823-11	RES-CHIP	1.5K	5%	1/10W	C702	1-136-165-00	FILM	0.1µF	5%	50V
R410	1-216-823-11	RES-CHIP	1.5K	5%	1/10W	C703	1-126-947-11	ELECT	47µF	20%	25V
R411	1-216-809-11	RES-CHIP	100	5%	1/10W	C704	1-107-652-11	ELECT	10µF	20%	250V
R412	1-218-713-11	METAL CHIP	7.5K	0.50%	1/16W	C705	1-107-652-11	ELECT	10µF	20%	250V
R413	1-216-829-11	RES-CHIP	4.7K	5%	1/10W	C706	1-137-528-11	MYLAR	0.1µF	10%	250V
R414	1-216-833-11	RES-CHIP	10K	5%	1/10W	C707	1-162-114-00	CERAMIC	0.0047µF		2KV
R415	1-249-411-11	CARBON	330	5%	1/4W	C708	1-136-165-00	FILM	0.1µF	5%	50V
R416	1-216-837-11	RES-CHIP	22K	5%	1/10W	C709	1-126-964-11	ELECT	10µF	20%	50V
R417	1-216-837-11	RES-CHIP	22K	5%	1/10W	C710	1-126-964-11	ELECT	10µF	20%	50V
R418	1-216-829-11	RES-CHIP	4.7K	5%	1/10W	C711	1-102-074-00	CERAMIC	0.001µF	10%	50V
R419	1-216-833-11	RES-CHIP	10K	5%	1/10W	CONNECTOR					
R420	1-216-852-11	RES-CHIP	390K	5%	1/10W	* CN701	1-564-506-11	PLUG,CONNECTOR			3P
R421	1-216-809-11	RES-CHIP	100	5%	1/10W	CN702	1-695-915-11	TAB (CONTACT)			
R422	1-216-809-11	RES-CHIP	100	5%	1/10W	CN704	1-785-879-11	CONNECTOR, ONE TOUCH			
R423	1-216-852-11	RES-CHIP	390K	5%	1/10W	* CN705	1-564-511-11	PLUG,CONNECTOR			8P
R424	1-216-823-11	RES-CHIP	1.5K	5%	1/10W	* CN706	1-564-510-11	PLUG,CONNECTOR			7P
R425	1-216-827-11	RES-CHIP	3.3K	5%	1/10W	* CN707	1-560-124-00	PLUG,CONNECTOR (2.5MM)			4P
R426	1-218-731-11	METAL CHIP	43K	0.50%	1/16W	(KV-36FV300 ONLY)					
R427	1-216-827-11	RES-CHIP	3.3K	5%	1/10W	DIODE					
R428	1-216-825-11	RES-CHIP	2.2K	5%	1/10W	D701	8-719-901-83	DIODE 1SS83TD			
R429	1-216-825-11	RES-CHIP	2.2K	5%	1/10W	D702	8-719-901-83	DIODE 1SS83TD			
R430	1-218-700-11	METAL CHIP	2.2K	0.50%	1/16W	D703	8-719-901-83	DIODE 1SS83TD			
R431	1-218-700-11	METAL CHIP	2.2K	0.50%	1/16W	D704	8-719-302-43	DIODE RGP10GPKG23			
R432	1-218-731-11	METAL CHIP	43K	0.50%	1/16W						
R433	1-216-826-11	RES-CHIP	2.7K	5%	1/10W						
R434	1-216-826-11	RES-CHIP	2.7K	5%	1/10W						
R435	1-216-797-11	RES-CHIP	10	5%	1/10W						

NOTE: The components identified by shading and  mark are critical for safety. Replace only with part number specified.

NOTE: Les composants identifiés par un trame et une marque  sont critiques pour la sécurité. Ne les remplacer que par une pièce portant le numéro spécifique.







REF. NO.	PART NO.	DESCRIPTION	VALUES			REF. NO.	PART NO.	DESCRIPTION	VALUES			
IC												
IC701	8-759-803-42	IC LA6500-FA										
IC702	8-759-562-43	IC TDA6108JF/N1B										
COIL						* A-1400-461-A V (VAR) BOARD, MOUNTED (KV-32FV300 ONLY)						
L701	1-408-613-31	INDUCTOR	68	μH		* A-1400-565-A V (VAR) BOARD, MOUNTED (KV-27FV300/29FV300 ONLY)						
TRANSISTOR						* A-1400-581-A V (VAR) BOARD, MOUNTED (KV-36FV300 ONLY)						
Q700	8-729-423-33	TRANSISTOR 2SC3311A-QRSTA				4-382-854-11	SCREW (M3X10), P, SW (+)					
Q701	8-729-423-33	TRANSISTOR 2SC3311A-QRSTA				CAPACITOR						
RESISTOR						C802	1-126-964-11	ELECT	10	μF	20%	50V
R700	1-249-433-11	CARBON	22K	5%	1/4W	C803	1-137-378-11	MYLAR	0.22	μF	5%	50V
R701	1-249-429-11	CARBON	10K	5%	1/4W	C804	1-137-378-11	MYLAR	0.22	μF	5%	50V
R702	1-249-409-11	CARBON	220	5%	1/4W	C805	1-129-763-61	FILM	0.033	μF	5%	200V
R703	1-247-807-31	CARBON	100	5%	1/4W	C808	1-162-970-11	CERAMIC CHIP	0.01	μF	10%	25V
R704	1-249-426-11	CARBON	5.6K	5%	1/4W	C809	1-128-934-91	CERAMIC CHIP	0.33	μF	20%	10V
R705	1-249-429-11	CARBON	10K	5%	1/4W	C810	1-130-495-00	MYLAR	0.1	μF	5%	50V
R706	1-249-381-11	CARBON	1	5%	1/4W	C811	1-129-765-00	FILM	0.047	μF	5%	200V
 R707	1-249-383-11	CARBON	1.5	5%	1/4W	C812	1-162-970-11	CERAMIC CHIP	0.01	μF	10%	25V
R708	1-247-807-31	CARBON	100	5%	1/4W	C813	1-126-933-11	ELECT	100	μF	20%	16V
R709	1-247-807-31	CARBON	100	5%	1/4W	C821	1-162-970-11	CERAMIC CHIP	0.01	μF	10%	25V
R710	1-247-807-31	CARBON	100	5%	1/4W	C823	1-130-967-00	FILM	0.0027	μF	5%	50V
R711	1-260-328-11	CARBON	1K	5%	1/2W	C824	1-165-176-11	CERAMIC CHIP	0.047	μF	10%	16V
R712	1-260-328-11	CARBON	1K	5%	1/2W	C826	1-162-927-11	CERAMIC CHIP	100	pF	5%	50V
R713	1-260-328-11	CARBON	1K	5%	1/2W	C862	1-126-964-11	ELECT	10	μF	20%	50V
R714	1-260-087-11	CARBON	100	5%	1/2W	C901	1-107-667-11	ELECT	2.2	μF	20%	160V
R715	1-260-132-11	CARBON	560K	5%	1/2W	C902	1-107-364-11	MYLAR	0.01	μF	10%	200V
R716	1-260-123-11	CARBON	100K	5%	1/2W	C903	1-126-935-11	ELECT	470	μF	20%	16V
R718	1-216-373-11	METAL OXIDE	2.2	5%	2W	C904	1-130-471-00	MYLAR	0.001	μF	5%	50V
R719	1-215-888-00	METAL OXIDE	220	5%	2W	C905	1-107-364-11	MYLAR	0.01	μF	10%	200V
R720	1-249-421-11	CARBON	2.2K	5%	1/4W	C906	1-130-471-00	MYLAR	0.001	μF	5%	50V
R721	1-249-421-11	CARBON	2.2K	5%	1/4W	C907	1-107-963-11	ELECT	33	μF	20%	160V
R722	1-247-807-31	CARBON	100	5%	1/4W	C908	1-126-935-11	ELECT	470	μF	20%	16V
R723	1-247-807-31	CARBON	100	5%	1/4W	C909	1-104-999-11	MYLAR	0.1	μF	10%	200V
R724	1-247-807-31	CARBON	100	5%	1/4W	C910	1-104-999-11	MYLAR	0.1	μF	10%	200V
VARIABLE RESISTOR						C911	1-126-933-11	ELECT	100	μF	20%	16V
RV701	1-241-656-11	RES,ADJ, METAL,FILM	110M			C912	1-126-933-11	ELECT	100	μF	20%	16V
						C913	1-102-074-00	CERAMIC	0.001	μF	10%	50V
						C914	1-130-491-00	MYLAR	0.047	μF	5%	50V
						C930	1-126-935-11	ELECT	470	μF	20%	6.3V
						C931	1-126-935-11	ELECT	470	μF	20%	6.3V

NOTE: The components identified by shading and  mark are critical for safety. Replace only with part number specified.

NOTE: Les composants identifiés par un trame et une  sont critiques pour la sécurité. Ne les remplacer que par une pièce portant le numéro spécifique.



REF. NO.	PART NO.	DESCRIPTION	VALUES	REF. NO.	PART NO.	DESCRIPTION	VALUES
CONNECTOR				Q907	8-729-120-28	TRANSISTOR 2SC2412K-T-146-QR	
* CN901	1-764-333-11	PLUG,CONNECTOR	10P	Q908	8-729-424-02	TRANSISTOR 2SB709A-QRS-TX	
* CN902	1-770-723-11	CONNECTOR, BOARD TO BOARD	8P	RESISTOR			
DIODE				R809	1-216-832-11	RES-CHIP	8.2K 5% 1/10W
D804	8-719-302-43	DIODE RGP10GPKG23		R811	1-249-393-11	CARBON	10 5% 1/4W
D805	8-719-991-33	DIODE 1SS133T-77		R814	1-215-862-11	METAL OXIDE	68 5% 1W
D806	8-719-991-33	DIODE 1SS133T-77		(KV-32FV300/36FV300 ONLY)			
D807	8-719-210-21	DIODE ERA82-004TP5		R815	1-215-862-11	METAL OXIDE	68 5% 1W
D808	8-719-991-33	DIODE 1SS133T-77		R817	1-218-734-11	METAL CHIP	56K 0.50% 1/16W
D813	8-719-991-33	DIODE 1SS133T-77		R818	1-216-809-11	RES-CHIP	100 5% 1/10W
D901	8-719-924-11	DIODE MTZJ-T-77-22		R819	1-216-841-11	RES-CHIP	47K 5% 1/10W
D902	8-719-924-11	DIODE MTZJ-T-77-22		R820	1-216-837-11	RES-CHIP	22K 5% 1/10W
D903	8-719-991-33	DIODE 1SS133T-77		R821	1-218-728-11	METAL CHIP	33K 0.50% 1/16W
D905	8-719-510-02	DIODE D1NS4-TR		R822	1-216-841-11	RES-CHIP	47K 5% 1/10W
D906	8-719-404-50	DIODE MA111-TX		R824	1-218-740-11	METAL CHIP	100K 0.50% 1/16W
D907	8-719-404-50	DIODE MA111-TX		R825	1-216-845-11	RES-CHIP	100K 5% 1/10W
D908	8-719-404-50	DIODE MA111-TX		R826	1-249-421-11	CARBON	2.2K 5% 1/4W
IC				R827	1-218-708-11	METAL CHIP	4.7K 0.50% 1/16W
IC801	6-701-598-01	IC UPC5023CS-184		R828	1-218-728-11	METAL CHIP	33K 0.50% 1/16W
CHIP CONDUCTOR				R829	1-216-797-11	RES-CHIP	10 5% 1/10W
JR802	1-216-864-11	SHORT		R833	1-216-830-11	RES-CHIP	5.6K 5% 1/10W
COIL				R834	1-216-830-11	RES-CHIP	5.6K 5% 1/10W
L801	1-406-989-21	INDUCTOR	10MH	R840	1-218-736-11	METAL CHIP	68K 0.50% 1/16W
L802	1-459-111-00	INDUCTOR	10MH	R841	1-216-826-11	RES-CHIP	2.7K 5% 1/10W
L803	1-412-529-81	INDUCTOR	22μH	R842	1-216-825-11	RES-CHIP	2.2K 5% 1/10W
L901	1-412-528-11	INDUCTOR	18μH	R855	1-216-835-11	RES-CHIP	15K 5% 1/10W
TRANSISTOR				R856	1-216-827-11	RES-CHIP	3.3K 5% 1/10W
Q805	6-550-106-01	TRANSISTOR KTB764		R857	1-218-728-11	METAL CHIP	33K 0.50% 1/16W
Q807	8-729-931-45	TRANSISTOR IRF614		R860	1-216-833-11	RES-CHIP	10K 5% 1/10W
Q808	6-550-106-01	TRANSISTOR KTB764		R864	1-218-668-11	METAL CHIP	100 0.50% 1/16W
Q812	8-729-026-39	TRANSISTOR 2SA933AS-QRT		R866	1-249-438-11	CARBON	56K 5% 1/4W
Q901	8-729-045-04	TRANSISTOR 2SC5511		R870	1-216-825-11	RES-CHIP	2.2K 5% 1/10W
Q902	8-729-045-05	TRANSISTOR 2SA2005		R876	1-216-821-11	RES-CHIP	1K 5% 1/10W
Q903	8-729-422-27	TRANSISTOR 2SD601A-QRS-TX		R890	1-218-867-11	RES-CHIP	6.8K 5% 1/10W
Q904	8-729-422-27	TRANSISTOR 2SD601A-QRS-TX		R893	1-216-839-11	RES-CHIP	33K 5% 1/10W
Q905	8-729-424-02	TRANSISTOR 2SB709A-QRS-TX		 R901	1-249-405-11	CARBON	100 5% 1/4W
Q906	8-729-120-28	TRANSISTOR 2SC2412K-T-146-QR		 R902	1-249-385-11	CARBON	2.2 5% 1/4W
				 R903	1-249-414-11	CARBON	560 5% 1/4W
				R904	1-249-432-11	CARBON	18K 5% 1/4W
				R905	1-249-421-11	CARBON	2.2K 5% 1/4W
				R906	1-249-432-11	CARBON	18K 5% 1/4W
				 R907	1-249-385-11	CARBON	2.2 5% 1/4W
				 R908	1-249-414-11	CARBON	560 5% 1/4W
				R909	1-260-316-51	CARBON	100 5% 1/2W

NOTE: The components identified by shading and \triangle mark are critical for safety. Replace only with part number specified.

NOTE: Les composants identifiés par un trame et une marque \triangle sont critiques pour la sécurité. Ne les remplacer que par une pièce portant le numéro spécifique.













REF. NO.	PART NO.	DESCRIPTION	VALUES	REF. NO.	PART NO.	DESCRIPTION	VALUES
C1458	1-162-970-11	CERAMIC CHIP	0.01 μ F 10% 25V				
C1461	1-113-619-11	CERAMIC CHIP	0.47 μ F 10V				
C1462	1-113-619-11	CERAMIC CHIP	0.47 μ F 10V				
C1463	1-126-968-11	ELECT	100 μ F 20% 50V				
CONNECTOR				FUSE			
*	CN503	1-573-963-11	PIN,CONNECTOR (PC BOARD) 3P	\triangle F601	1-576-193-11	FUSE	6.3A/125V (KV-27FV300/29FV300(N)/32FV300/36FV300 ONLY)
	CN600	1-580-843-11	PIN,CONNECTOR (POWER)	\triangle F601	1-532-506-51	FUSE	6.3A/250V (KV-29FV300(S) ONLY)
*	CN602	1-564-510-11	PLUG,CONNECTOR 7P	FERRITE BEAD			
	CN603	1-695-915-11	TAB (CONTACT)	FB602	1-410-397-21	FERRITE	1.1 μ H
	CN604	1-695-915-11	TAB (CONTACT) (KV-27FV300/29FV300(N)/32FV300/36FV300 ONLY)	FB604	1-410-397-21	FERRITE	1.1 μ H
				FB605	1-410-397-21	FERRITE	1.1 μ H
*	CN605	1-564-506-11	PLUG,CONNECTOR 3P	FB609	1-410-397-21	FERRITE	1.1 μ H
*	CN1401	1-564-507-11	PLUG,CONNECTOR 4P	FB610	1-410-397-21	FERRITE	1.1 μ H
	CN1402	1-564-505-11	PLUG,CONNECTOR 2P	FB611	1-410-397-21	FERRITE	1.1 μ H
*	CN1405	1-564-506-11	PLUG,CONNECTOR 3P	FB612	1-410-397-21	FERRITE	1.1 μ H
*	CN1601	1-564-509-11	PLUG,CONNECTOR 6P	FB614	1-410-397-21	FERRITE	1.1 μ H
				FB616	1-410-397-21	FERRITE	1.1 μ H
				FB617	1-410-397-21	FERRITE	1.1 μ H
DIODE				IC			
D501	8-719-404-50	DIODE MA111-TX		IC600	8-759-670-30	IC MCZ3001D	
D600	8-719-510-53	DIODE D4SB60L-F		IC601	8-749-012-13	IC DM-58	
D601	8-719-511-40	DIODE S1VB20		\triangle IC602	1-761-541-11	SELECTION UNIT, RECTIFICATION (KV-36FV300 ONLY)	
D611	8-719-062-40	DIODE D4SBL20 μ F3		IC605	8-759-450-47	IC BA05T	
D612	8-719-068-00	DIODE ERC04-06SE (KV-27FV300/29FV300(N)/32FV300/36FV300 ONLY)		IC609	8-759-653-07	IC PQ09RD21	
D613	8-719-068-00	DIODE ERC04-06SE (KV-27FV300/29FV300(N)/32FV300/36FV300 ONLY)		IC1405	8-759-573-40	IC TDA8580Q/N1	
D614	8-719-057-52	DIODE EZ0150AV1		IC1406	8-759-100-96	IC NJM4558M-TE2	
D615	8-719-062-40	DIODE D4SBL20 μ F3		CHIP CONDUCTOR			
D618	8-719-979-64	DIODE μ F4005PKG23		JR1	1-216-864-11	SHORT	
D620	8-719-404-50	DIODE MA111-TX		JR2	1-216-864-11	SHORT	
D621	6-500-181-01	DIODE MA6D50		JR3	1-216-864-11	SHORT	
D624	8-719-510-12	DIODE D10SC4M		JR6	1-216-864-11	SHORT	
D625	8-719-510-02	DIODE D1NS4-TA2		JR1400	1-216-864-11	SHORT	
D628	8-719-404-50	DIODE MA111-TX		JR1401	1-216-864-11	SHORT	
D629	8-719-110-31	DIODE MTZJ-T-77-12C		JR1404	1-216-864-11	SHORT	
D631	8-719-063-70	DIODE D1NL20U-TA2		JR1405	1-216-864-11	SHORT	
D640	8-719-404-50	DIODE MA111-TX		JR1409	1-216-864-11	SHORT	
D641	8-719-404-50	DIODE MA111-TX		JR1411	1-216-864-11	SHORT	
D645	8-719-063-70	DIODE D1NL20U-TA2		JR1412	1-216-864-11	SHORT	
D646	8-719-404-50	DIODE MA111-TX		COIL			
D647	8-719-063-70	DIODE D1NL20U-TA2		L505	1-412-529-11	INDUCTOR	22 μ H
D690	8-719-982-13	DIODE MTZJ-T-77-27		L604	1-412-525-31	INDUCTOR	10 μ H
D1401	8-719-929-15	DIODE MTZJ-T-77-9.1B		L605	1-412-519-11	INDUCTOR	3.3 μ H
				L606	1-412-519-11	INDUCTOR	3.3 μ H

NOTE: The components identified by shading and  mark are critical for safety. Replace only with part number specified.

NOTE: Les composants identifiés par un trame et une marque  sont critiques pour la sécurité. Ne les remplacer que par une pièce portant le numéro spécifique.









REF. NO.	PART NO.	DESCRIPTION	VALUES			REF. NO.	PART NO.	DESCRIPTION	VALUES			
L607	1-412-525-31	INDUCTOR	10µH			R626	1-218-715-11	METAL CHIP	9.1K	0.50%	1/16W	
L608	1-412-529-11	INDUCTOR	22µH			R627	1-215-481-00	METAL	330K	1%	1/4W	
PHOTO COUPLER						R628	1-260-131-11	CARBON	470K	5%	1/2W	
	PH602	8-749-924-35	PHOTO COUPLER	ON3171-R		(KV-29FV300(S) ONLY)						
IC LINK						R629	1-215-481-00	METAL	330K	1%	1/4W	
PS601	1-576-337-21	LINK, IC					R630	1-215-481-00	METAL	330K	1%	1/4W
PS1401	1-576-337-21	LINK, IC				R631	1-218-720-11	METAL CHIP	15K	0.50%	1/16W	
TRANSISTOR						R632	1-218-668-11	METAL CHIP	100	0.50%	1/16W	
Q509	8-729-423-33	TRANSISTOR 2SC3311A-QRSTA					R640	1-249-417-11	CARBON	1K	5%	1/4W
Q600	8-729-052-32	TRANSISTOR IRFIB7N50A-LF31				R647	1-218-667-11	METAL CHIP	91	0.50%	1/16W	
Q601	8-729-052-32	TRANSISTOR IRFIB7N50A-LF31					R658	1-249-393-11	CARBON	10	5%	1/4W
Q605	8-729-140-96	TRANSISTOR 2SD774-T-34					R659	1-249-393-11	CARBON	10	5%	1/4W
Q606	8-729-422-27	TRANSISTOR 2SD601A-QRS-TX				R660	1-216-833-11	RES-CHIP	10K	5%	1/10W	
Q608	8-729-922-37	TRANSISTOR 2SD2144S-TP-UVVW				R667	1-216-833-11	RES-CHIP	10K	5%	1/10W	
Q690	8-729-424-02	TRANSISTOR 2SB709A-QRS-TX					R668	1-249-413-11	CARBON	470	5%	1/4W
Q691	8-729-424-02	TRANSISTOR 2SB709A-QRS-TX				R670	1-216-833-11	RES-CHIP	10K	5%	1/10W	
Q1401	8-729-424-02	TRANSISTOR 2SB709A-QRS-TX				R671	1-243-979-71	METAL OXIDE	0.1	5%	2W	
RESISTOR						R672	1-243-979-71	METAL OXIDE	0.1	5%	2W	
R534	1-216-833-11	RES-CHIP	10K	5%	1/10W	R687	1-205-998-11	CEMENTED	1	5%	10W	
R535	1-216-825-11	RES-CHIP	2.2K	5%	1/10W	R688	1-205-998-11	CEMENTED	1	5%	10W	
	R603	1-219-513-11	CARBON	4.7M	5%	1/2W	R691	1-216-837-11	RES-CHIP	22K	5%	1/10W
(KV-27FV300/29FV300(N)/32FV300/36FV300 ONLY)						R692	1-216-837-11	RES-CHIP	22K	5%	1/10W	
R604	1-216-833-11	RES-CHIP	10K	5%	1/10W	R694	1-216-837-11	RES-CHIP	22K	5%	1/10W	
R606	1-216-833-11	RES-CHIP	10K	5%	1/10W	R698	1-249-377-11	CARBON	0.47	5%	1/4W	
R607	1-216-833-11	RES-CHIP	10K	5%	1/10W		R699	1-218-265-11	METAL	8.2M	5%	1W
R608	1-216-833-11	RES-CHIP	10K	5%	1/10W	(KV-29FV300(S) ONLY)						
R609	1-205-998-11	CEMENTED	1	5%	10W	R1401	1-216-837-11	RES-CHIP	22K	5%	1/10W	
R610	1-216-833-11	RES-CHIP	10K	5%	1/10W	R1402	1-216-837-11	RES-CHIP	22K	5%	1/10W	
R611	1-216-833-11	RES-CHIP	10K	5%	1/10W	R1403	1-216-833-11	RES-CHIP	10K	5%	1/10W	
R612	1-260-131-11	CARBON	470K	5%	1/2W	R1404	1-216-840-11	RES-CHIP	39K	5%	1/10W	
(KV-29FV300(S) ONLY)						R1405	1-216-840-11	RES-CHIP	39K	5%	1/10W	
R613	1-216-833-11	RES-CHIP	10K	5%	1/10W	R1406	1-216-840-11	RES-CHIP	39K	5%	1/10W	
R614	1-216-825-11	RES-CHIP	2.2K	5%	1/10W	R1407	1-216-817-11	RES-CHIP	470	5%	1/10W	
R615	1-202-933-61	FUSIBLE	0.1	10%	1/2W	R1408	1-216-817-11	RES-CHIP	470	5%	1/10W	
R616	1-216-822-11	RES-CHIP	1.2K	5%	1/10W	R1409	1-216-829-11	RES-CHIP	4.7K	5%	1/10W	
R617	1-216-821-11	RES-CHIP	1K	5%	1/10W	R1410	1-216-829-11	RES-CHIP	4.7K	5%	1/10W	
R618	1-216-864-11	SHORT				R1411	1-216-821-11	RES-CHIP	1K	5%	1/10W	
	R619	1-249-377-11	CARBON	0.47	5%	1/4W	R1412	1-218-684-11	METAL CHIP	470	0.50%	1/16W
R620	1-215-857-71	METAL OXIDE	10	5%	1W	R1413	1-216-789-11	RES-CHIP	2.2	5%	1/10W	
R625	1-216-817-11	RES-CHIP	470	5%	1/10W	R1414	1-216-809-11	RES-CHIP	100	5%	1/10W	
						R1415	1-216-837-11	RES-CHIP	22K	5%	1/10W	
						R1416	1-216-825-11	RES-CHIP	2.2K	5%	1/10W	
						R1457	1-218-708-11	METAL CHIP	4.7K	0.50%	1/16W	
						R1458	1-218-708-11	METAL CHIP	4.7K	0.50%	1/16W	

NOTE: The components identified by shading and  mark are critical for safety. Replace only with part number specified.

NOTE: Les composants identifiés par un trame et une marque  sont critiques pour la sécurité. Ne les remplacer que par une pièce portant le numéro spécifique.



REF. NO.	PART NO.	DESCRIPTION	VALUES	REF. NO.	PART NO.	DESCRIPTION	VALUES
R1461	1-218-716-11	METAL CHIP	10K 0.50% 1/16W	*	4-086-349-01	CARTON, HSC (KV-36FV300 ONLY)	
R1462	1-218-716-11	METAL CHIP	10K 0.50% 1/16W				
R1481	1-216-833-11	RES-CHIP	10K 5% 1/10W		4-087-224-01	CARTON, INDIVIDUAL (KV-27FV300/29FV300 ONLY)	
R1482	1-216-829-11	RES-CHIP	4.7K 5% 1/10W				
R1487	1-216-864-11	SHORT					
RELAY							
	RY501	1-755-198-11	RELAY	*	4-085-911-01	CUSHION, FRONT (UPPER) (KV-32FV300 ONLY)	
	RY600	1-755-395-11	RELAY (AC POWER)	*	4-805-912-01	CUSHION, REAR (UPPER) (KV-32FV300 ONLY)	
				*	4-805-913-01	CUSHION, LOWER (KV-32FV300 ONLY)	
TRANSFORMER							
	T601	1-435-617-11	TRANSFORMER, LINE FILTER	*	4-086-352-01	CUSHION, FRONT (UPPER) (KV-36FV300 ONLY)	
	T603	1-437-783-11	TRANSFORMER, STAND BY (KV-27FV300/29FV300(N)/32FV300/36FV300 ONLY)	*	4-086-353-01	CUSHION, REAR (UPPER) (KV-36FV300 ONLY)	
	T603	1-437-784-11	TRANSFORMER, STAND BY (KV-29FV300(S) ONLY)	*	4-086-354-01	CUSHION, LOWER (KV-36FV300 ONLY)	
	T604	1-437-607-11	POWER ISOLATION TRANSFORMER	*	4-087-222-01	CUSHION, UPPER (KV-27FV300/29FV300 ONLY)	
	T605	1-437-785-11	TRANSFORMER ASSY POWER (HST) (KV-36FV300 ONLY)	*	4-087-223-01	CUSHION, LOWER (KV-27FV300/29FV300 ONLY)	
THERMISTOR							
THP501	1-803-540-11	THERMISTOR, POSITIVE (KV-29FV300(S) ONLY)			4-086-346-21	MANUAL, INSTRUCTION (KV-27FV300/32FV300/36FV300 ONLY)	
THP501	1-803-629-11	THERMISTOR, POSITIVE (KV-36FV300 ONLY)			4-086-346-31	MANUAL, INSTRUCTION (KV-27FV300(CND)/32FV300(CND)/36FV300(CND) ONLY)	
THP501	1-804-313-11	THERMISTOR, POSITIVE (KV-27FV300/29FV300(N)/32FV300 ONLY)			4-086-346-41	MANUAL, INSTRUCTION (KV-29FV300 ONLY)	
VARISTOR							
VDR600	1-803-585-11	VARISTOR ENE271D-10A (KV-27FV300/29FV300(N)/32FV300/36FV300 ONLY)			4-041-255-01	BAG, PROTECTION (KV-27FV300/29FV300 ONLY)	
VDR600	1-803-967-11	VARISTOR ENE621D-14A (KV-29FV300(S) ONLY)			4-066-845-02	BAG, PROTECTION (KV-32FV300 ONLY)	
				*	4-087-598-01	BAG, PROTECTION (KV-36FV300 ONLY)	
					8-953-742-90	HEADPHONE MDR-IF0230//K SET (KV-32FV300/36FV300 ONLY)	
A-1400-607-A HD BOARD, MOUNTED (KV-32FV300/36FV300 ONLY)							
ACCESSORIES AND PACKING							
*	4-041-423-01	SHEET, PROTECTION (KV-36FV300 ONLY)			4-476-668-11	REMOTE COMMANDER (RM-Y182) (KV-32FV300/36FV300 ONLY)	
	4-085-910-01	CARTON, INDIVIDUAL (KV-32FV300 ONLY)			4-476-681-11	REMOTE COMMANDER (RM-Y181) (KV-27FV300/29FV300)	
					4-978-977-11	BATTERY COVER (KV-RM-Y181/RM-Y182)	
						REMOTE COMMANDER	



* **A-1400-607-A HD BOARD, MOUNTED**
(KV-32FV300/36FV300 ONLY)

ACCESSORIES AND PACKING

* 4-041-423-01 SHEET, PROTECTION
(KV-36FV300 ONLY)

4-085-910-01 CARTON, INDIVIDUAL
(KV-32FV300 ONLY)

Sony Corporation
Sony Technology Center
Technical Services
Service Promotion Department

English
2002CJ74059-1
Printed in USA
© 2002.3

14 | 15 | 16 | 17 | 18 | 19 | 20 | 21 | 22 | 23 | 24

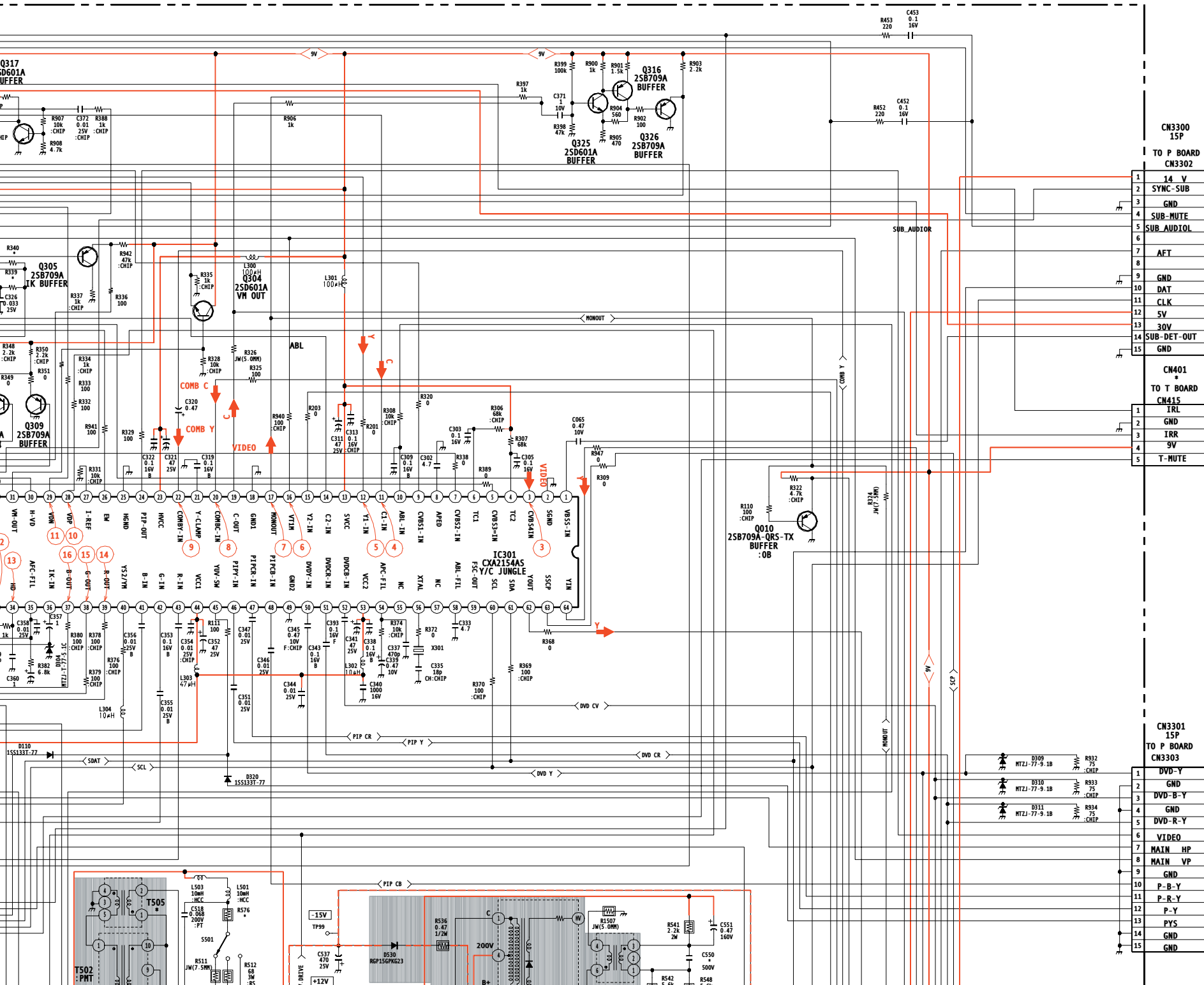

CN3300 15P
TO P BOARD
CN3302

1	14_V
2	SYNC-SUB
3	GND
4	SUB-MUTE
5	SUB_AUDIOR
6	
7	AFT
8	
9	GND
10	DAT
11	CLK
12	5V
13	30V
14	SUB-DET-OUT
15	GND

CN401 *
TO T BOARD
CN415

1	IRL
2	GND
3	IRR
4	9V
5	T-MUTE

CN3301 15P
TO P BOARD
CN3303

1	DVD-Y
2	GND
3	DVD-B-Y
4	GND
5	DVD-R-Y
6	VIDEO
7	MAIN HP
8	MAIN VP
9	GND
10	P-B-Y
11	P-R-Y
12	P-Y
13	PYS
14	GND
15	GND

H
I
J
K
L
M
N
O
P

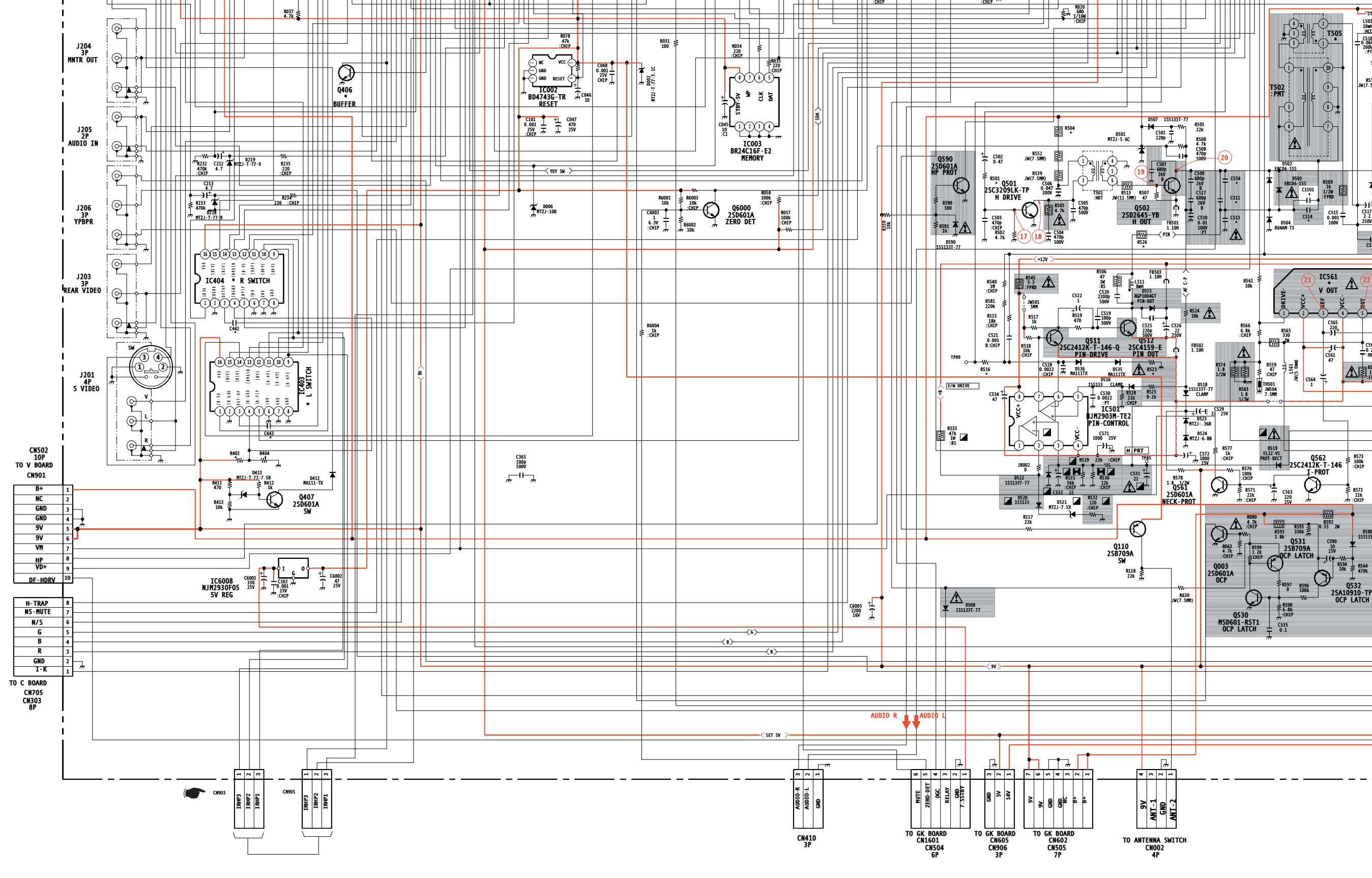

CN502
TO V BOARD
CN901

B+	1
NC	2
GND	3
GND	4
9V	5
9V	6
VH	7
HP	8
VD+	9
DF-HDRV	10

TO C BOARD
CN705
CN303
8P

H-TRAP	8
NS-MUTE	7
N/S	6
G	5
B	4
R	3
GND	2
I-K	1

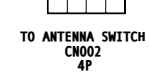
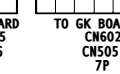
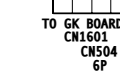
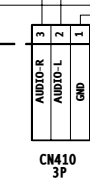
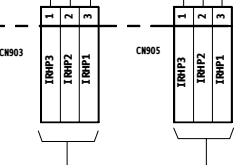

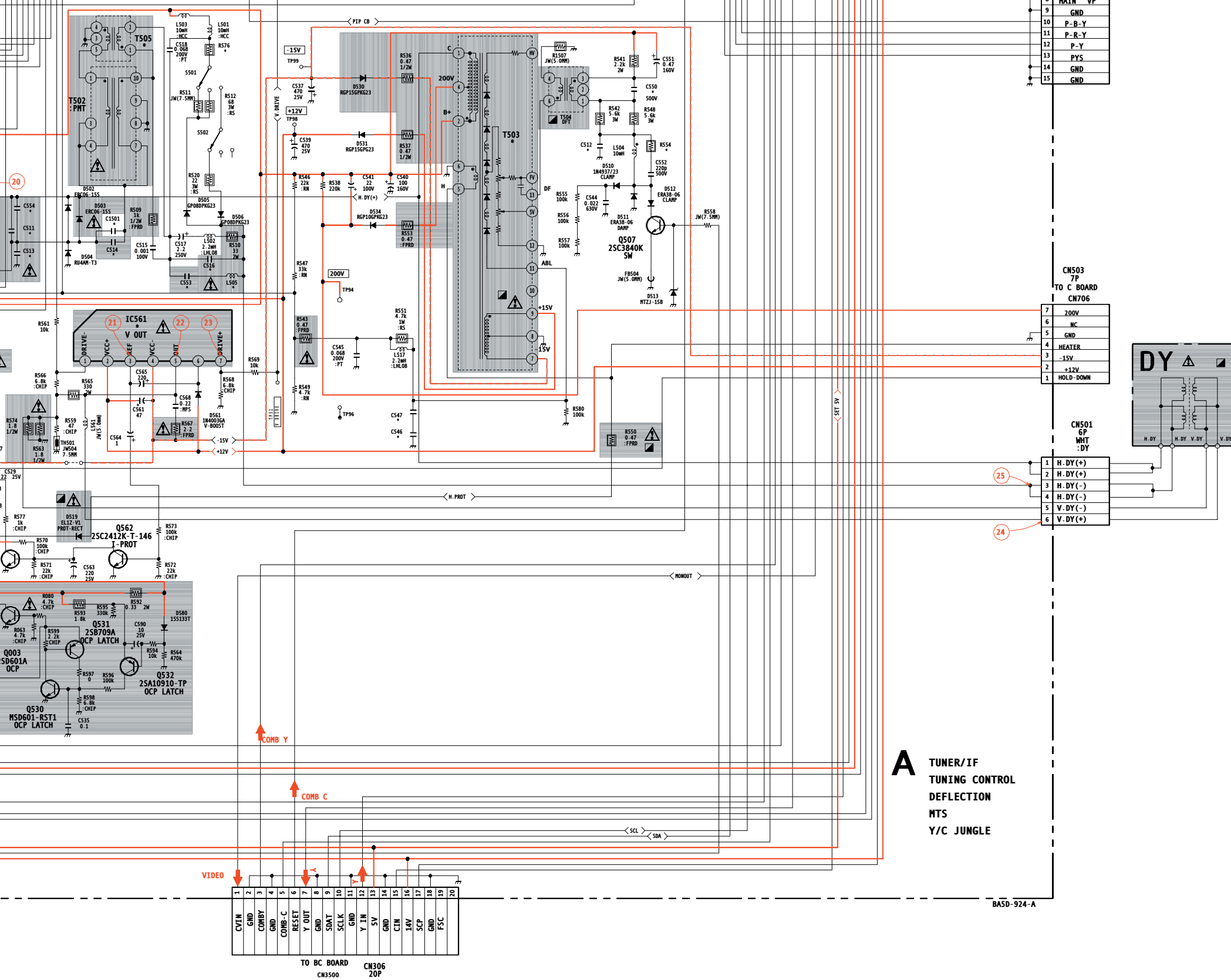

9	MAIN VP
10	GND
11	P-B-Y
12	P-R-Y
13	P-Y
14	PYS
15	GND

CN503	
7P	
TO C BOARD	
CN706	
7	200V
6	NC
5	GND
4	HEATER
3	-15V
2	+12V
1	HOLD-DOWN

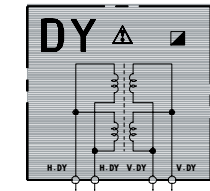

CN501	
6P	
MHT	
DY	
1	H. DY (+)
2	H. DY (+)
3	H. DY (-)
4	H. DY (-)
5	V. DY (-)
6	V. DY (+)

A TUNER/IF
TUNING CONTROL
DEFLECTION
MTS
Y/C JUNGLE

BASD-924-A

VIDEO	1	2	3	4	5	6	7	8	9	10	11	12	13	14	15	16	17	18	19	20
	CVIN	GND	COMBY	GND	COMB-C	RESET	Y OUT	GND	SDAT	SCLK	GND	Y IN	5V	GND	CTIN	14V	SCP	GND	FSC	
	TO BC BOARD																			
	CN3500																			
	CN306																			
	20P																			

PRINTING THE SERVICE MANUAL

The PDF of this service manual is not designed to be printed from cover to cover. The pages vary in size, and must therefore be printed in sections based on page dimensions.

NON-SCHEMATIC PAGES

Data that does NOT INCLUDE schematic diagrams are formatted to 8.5 x 11 inches and can be printed on standard letter-size and/or A4-sized paper.

SCHEMATIC DIAGRAMS

The schematic diagram pages are provided in two ways, full size and tiled. The full-sized schematic diagrams are formatted on paper sizes between 8.5" x 11" and 18" x 30" depending upon each individual diagram size. Those diagrams that are LARGER than 11" x 17" in full-size mode have been tiled for your convenience and can be printed on standard 11" x 17" (tabloid-size) paper, and reassembled.

TO PRINT FULL SIZE SCHEMATIC DIAGRAMS

If you have access to a large paper plotter or printer capable of outputting the full-sized diagrams, output as follows:

- 1) Note the page size(s) of the schematics you want to output as indicated in the middle window at the bottom of the viewing screen.
- 2) Go to the File menu and select Print Set-up. Choose the printer name and driver for your large format printer. Confirm that the printer settings are set to output the indicated page size or larger.
- 3) Close the Print Set Up screen and return to the File menu. Select "Print..." Input the page number of the schematic(s) you want to print in the print range window. Choose OK.

TO PRINT TILED VERSION OF SCHEMATICS



Schematic pages that are larger than 11" x 17" full-size are provided in a 11" x 17" printable tiled format near the end of the document. These can be printed to tabloid-sized paper and assembled to full-size for easy viewing.

If you have access to a printer capable of outputting the tabloid size (11" x 17") paper, then output the tiled version of the diagram as follows:

- 1) Note the page number(s) of the schematics you want to output as indicated in the middle window at the bottom of the viewing screen.
- 2) Go to the File menu and select Print Set-up. Choose the printer name and driver for your printer. Confirm that the plotter settings are set to output 11" x 17", or tabloid size paper in landscape () mode.
- 3) Close the Print Set Up screen and return to the File menu. Select "Print..." Input the page number of the schematic(s) you want to print in the print range window. Choose OK.

TO PRINT SPECIFIC SECTIONS OF A SCHEMATIC

To print just a particular section of a PDF, rather than a full page, access the Graphics Select tool in the Acrobat Reader tool bar.

- 1) To view the Graphics Select Tool, press and HOLD the mouse button over the Text Select Tool which looks like: .
This tool will expand to reveal to additional tools.
Choose the Graphics Select tool by placing the cursor over the button on of the far right that looks like: 
- 2) After selecting the Graphics Select Tool, place your cursor in the document window and the cursor will change to a plus (+) symbol. Click and drag the cursor over the area you want to print. When you release the mouse button, a marquee (or dotted lined box) will be displayed outlining the area you selected.
- 3) With the marquee in place, go to the file menu and select the "Print..." option. When the print window appears, choose the option under the section called "Print Range" which says "Selected Graphic".

Select OK and the output will print only the area that you outlined with the marquee. 

(continued >)

ON-SCREEN SEARCH OPTION

All of the text within the service manual PDF is content searchable. This means that you can enter any text, word, phrase or reference number that appears in the manual, and the PDF software will search, find and move the cursor to the location where you requested text first appears. This feature can be particularly useful in locating components on a specific schematic or printed wire circuit board (PWB) diagrams.

Follow these steps to effectively locate a component on a schematic diagram:

- 1) Locate the schematic you want to search by clicking on the corresponding bookmark on the left side of the screen. The view on the right of the screen will then jump to the desired schematic page.
- 2) Magnify the diagram to at least 400% before conducting a component search. This will enable you to easily view the reference number when it is highlighted on screen. To do this, click on the magnifying glass button on the tool bar at the top of the screen. Move the cursor over the diagram and RIGHT click you mouse. Select the 400% magnification option on the pop-up menu. Click on the button with the icon of the open hand to deactivate the magnification tool
- 3) Search the diagram (or the entire manual) by clicking on the binocular button tool at the top of the screen. The "Find" window will appear and allow you to type in your desired text. Type in a reference designator, such as R502, and click on the "Find" button. If the component is not on the diagram, but is listed anywhere else in the manual, the cursor will jump to the first location the text is found in the file. To find another instance of that same text, click on the binocular button again and select "Find Again."